

Classification of Aurora and the Position of Auroral Zone near Syowa Base

Junji NAKAMURA*

オーロラの分類と昭和基地付近に於ける極光帯の位置

中 村 純 二*

要 旨

1959年日本南極第3次越冬隊は、昭和基地に於ていくつかのオーロラの光学的観測を行なった。観測地点は南緯69度00分、東経39度35分、高度14米である。全天カメラのフィルムと分光器のフィルムを統計的に調べることにより、オーロラ最頻度帯は昭和基地の南方に位置するこ

と、ならびにオーロラは大別して、(a)黄緑色のもの、(b)下縁の赤いもの、ならびに(c)上部赤或いは全部赤いものの3種類に分けられることが明らかとなった。極光帯の位置はこれら3種類のオーロラの各々について少しずつ異なり、又局所時によってもその位置を変えることが判明した。

Abstract

In 1959 III JARE (the third Japanese Antarctic Research Expedition) performed several optical observations of aurora at Syowa Base which is located at $69^{\circ}00'S$, $39^{\circ}35'E$ and 14 m above sea level. From statistical treatment of the all sky camera films and spectra, it has become known that the auroral maximum zone lies to the south of Syowa Base and aurora can be classified into the following three types; (a) yellow-greenish aurora, (b) aurora with red lower border, and (c) entirely red aurora or only the upper part red. It has also been unraveled that the position of auroral zone may be distinguished by its type and the position of each zone varies with local time.

1. Appearance frequency of aurora at Syowa Base

We could see aurora in 81 nights of the 85 clear dark nights during 1959. Therefore, Syowa Base belongs to 94 percent auroral zone. Figure 1 shows the auroral zone of the southern hemisphere drawn by BOND and JACKA¹⁾ deduced from the observed optical data obtained at Mawson, Macquarie, Hallet and Scott Bases in 1957. The dotted line also shows the auroral zone reduced from the geomagnetic data by VESTINE and SNYDER²⁾. It will be known that near Syowa Base the auroral zone may come about middle of them.

* 東京天文台、東京大学教養学部物理学教室、第1次及び第2次南極地域観測隊員、第3次南極地域観測隊越冬隊員。Institute of Physics, College of General Education, University of Tokyo. Tokyo Astronomical Observatory, University of Tokyo. Member of the Japanese Antarctic Research Expeditions, 1956-57 and 1957-58. Also Member of the Wintering Party of JARE 1959-60.

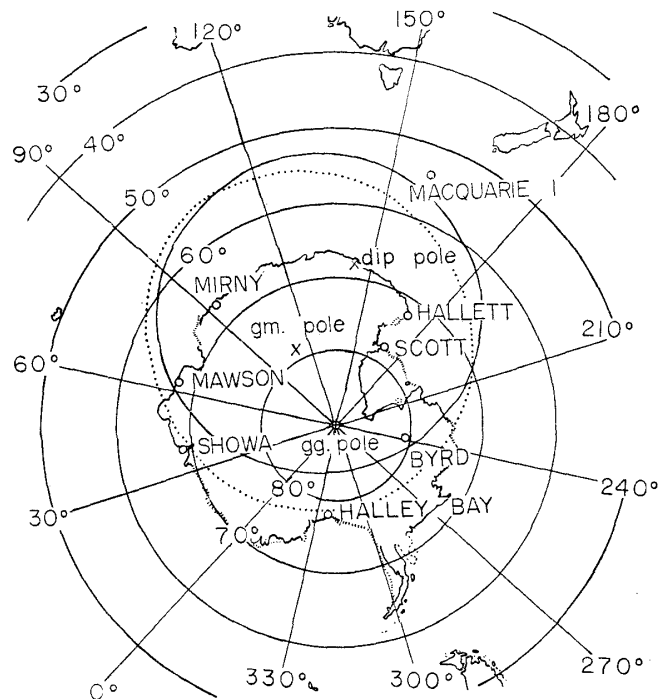

Fig. 1. Auroral maximum zone in the southern hemisphere.

Full line curve shows the zone drawn by BOND and JACKA from the 1957 optical data. Dotted line shows the zone reduced by VESTINE and SNYDER from the geomagnetic data before 1946.

Figure 2 shows the hourly frequency of appearance of visual aurora by month, of which full line corresponds to Syowa Base and dotted line corresponds to U. S. S. R. Mirny Base ($66^{\circ}33'S$, $93^{\circ}01'E$). Hourly frequency means the percentage of the number of aurora appeared to the number of whole graduations, after dividing each clear night into hourly graduations.

These hourly frequencies show that Syowa Base belongs to about 80 percent auroral zone and Mirny Base belongs to about 40 percent zone, irrespective of their almost identical geographic latitudes. The seasonal variation of the auroral zone shows a slight maximum in spring and autumn for both bases.

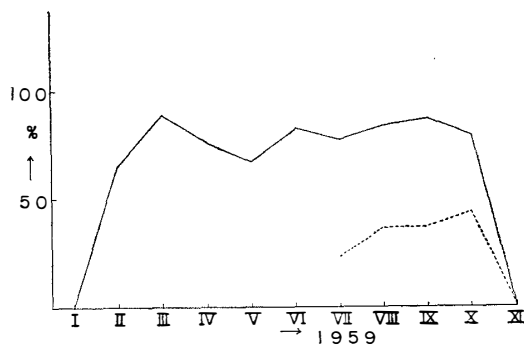

Fig. 2. Hourly frequency of appearance of aurora at Syowa Base (full line) and at Mirny Base (dotted line).

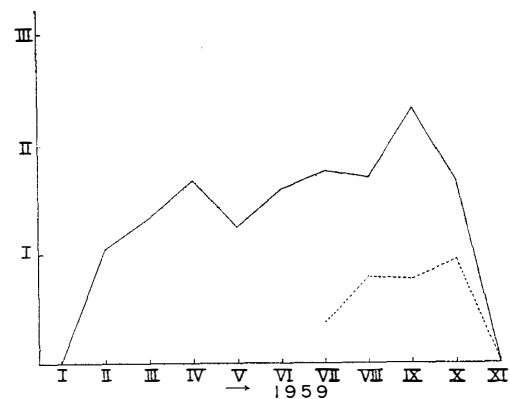

Fig. 3. Mean visual intensity of aurora at Syowa Base (full line) and at Mirny Base (dotted line).

Figure 3 shows the mean visual intensity of aurora by month. Generally speaking, auroral intensity varies with auroral frequency of appearance and its maximum occurs during the same season.

2. Auroral distribution along the geomagnetic meridian

We used the all sky camera of type shown in Figure 4 on the roof of our observation hut. The image of all sky by a large convex mirror was photographed every

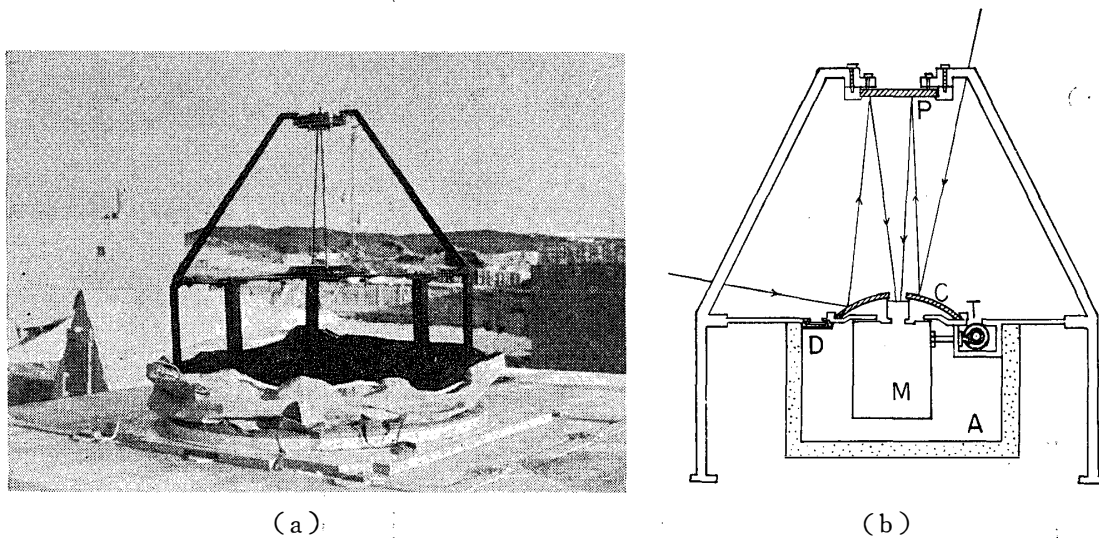

Fig. 4. All sky camera.

- a) Photograph showing the all sky camera being setting on the roof of our observation hut.
 b) Schematic view of all sky camera :

C: Convex mirror of radius 230 mm and diameter 300 mm. P: Plane mirror of diameter 160 mm. M: 16 mm Movie camera which lens is Nominor f:0.95. T: Radium painted time mark dial which is regulated by quartz oscillator. D: Radium painted data plate. A: Thermostatt.

minute on 16 mm cinefilm. Exposure time was 15 seconds. Sakura SSS film was developed by pandol for 20 minutes which gave about ASA 600. The movie camera and time marking dial were driven by a synchronous motor which was regulated by a quartz oscillator having precision of 10^{-4} .

A few examples of all sky films are shown in Figure 5 with corresponding still camera films. Of these all sky films, the top one corresponds to the geomagnetic north ($33^{\circ}30'W$ from geographical north) and the left side corresponds to the west. In these cases the still camera was directed to the west.

To decide the position of auroral zone, these all sky films were read separately by three regions, N, Z and S, according to Ascaplot of CSAGI³⁾. Diagram of these three regions is shown in Figure 6. If aurora appeared at the height of 100 km, the above graduation would have a width of three degrees along the geomagnetic meridian as seen

in Figure 6b. Small circles in Figure 6b show the point in a layer of 100 km high through which the axis of our scanning photometer passed.

As will be stated below, the position of the auroral zone depends on local time. In

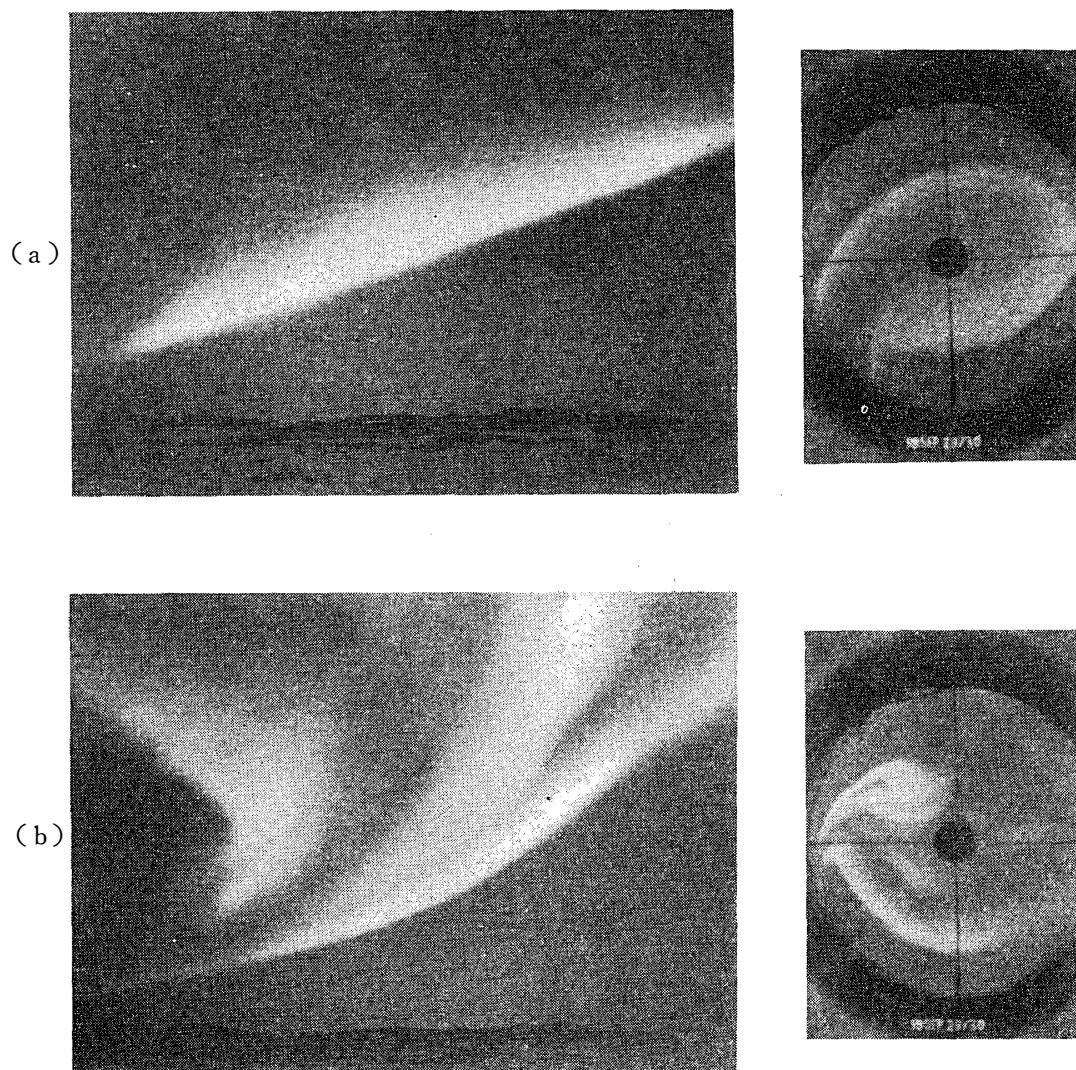

Fig. 5. Still camera film of aurora and corresponding all sky camera film.

- a) 1959, Sep. 19/30, 21:54 U. T. Quiet aurora.
- b) 1959, Sep. 29/30, 23:18 U. T. Active aurora.

order to study the directional distribution, we were obliged to choose 71 clear nights so that all-night can be performed.

We used 15 minutes graduation ; that is, from 53 m to 07m, from 08m to 22 m, from 23m to 37 m and from 38 m to 52 m every hour. Full line curve in Figure 7 shows the percentage frequency of appearance of all aurora in three regions N, Z and S. As the height of auroral emission layer is to be distinguished by auroral type and moreover an

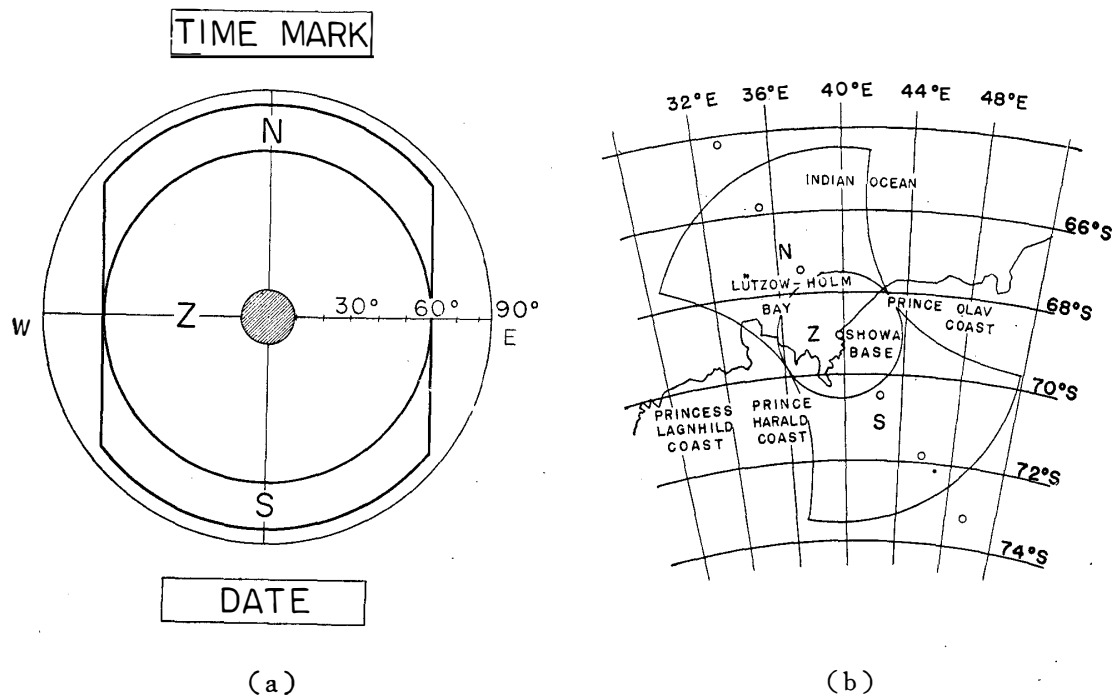

Fig. 6.

- a) Three regions of N, Z and S according to Ascaplot in a all sky camera film. Zenith angles are also wrote down.
- b) Corresponding regions of N, Z and S near Syowa Base.

effective area of Z, N or S region is different, we are unable to estimate the accurate position of a maximum zone, although the zone possibly lies somewhat south of our base.

According to ordinary classification of auroral intensity⁴⁾, we defined the O⁺ and I aurora as weak aurora and above I⁺ (I⁺, II, II⁺, III, III⁺, and IV) as strong aurora. The statistics of weak aurora (dashed line in Fig. 7.) shows that the percentage frequency becomes high in S-region; that is, the auroral zone seems to move somewhat to the south, while the statistics of strong aurora (dotted line in Fig. 7.) shows that the zone may lie almost above our base.

In 1959, seven world-wide magnetic storms occurred from Feb. 10 to 22, from May 11 to 20, from Jul. 11 to 30, from Aug. 20 to 26, from Sep. 3 to 9, from Sep. 19 to 22 and from Dec. 3 to 5 respectively. Figure 8 shows the percentage frequency of occurrence of stormy day aurora.

These statistics show similar effects as in Figure 7; the auroral zone of whole aurora lies toward south of Syowa Base, the zone of weak aurora lies further south, while strong aurora have its maximum zone nearly above our base. However, on the whole, the distribution of aurora appeared during storms is flat and shifts somewhat to the north, as compared with the one in quiet days.

It seems that the auroral zone does not always appear at the same place, but changes its position by their activity and moves with local time.

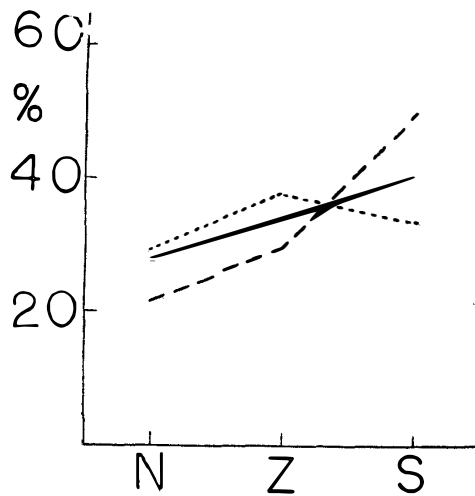

Fig. 7. Percentage frequency of occurrence of aurora observed at Syowa Base in 1959.

Full line curve represents the whole aurora. Dashed line refers to weak aurora (O^+ , I). Dotted line refers to strong aurora (I^+ , II , II^+ , III , III^+ , IV).

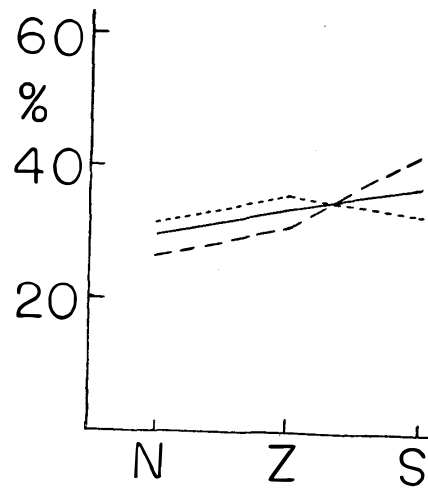

Fig. 8. Percentage frequency of occurrence of stormy time aurora observed at Syowa Base in 1959.

Full line curve represents whole aurora. Dashed line one is weak aurora. Dotted line one is strong aurora.

3. Classification of aurorae

Aurorae have been generally classified by their forms. However, this classification seems to have little physical meaning, because several parallel draperies having a constant height of lower border (e. g. 80 km) would be seen as a single arc or glow by the observer in lower latitude. Ray type aurora also may be judged as a homogeneous type when observed at a distant observatory.

If aurorae is classified by its colour, such confusion will not take place. In the present paper aurora is classified into three types: (a) yellow-greenish aurora, (b) aurora with red lower border and (c) entirely red aurora or only the upper part red.

In the previous section it was explained that the maximum zone of the aurora can be distinguished between weak aurora, strong aurora and stormy time aurora. The relation between these three types of aurora and their colour is shown in Table 1.

Table 1.

| | weak aurora | strong aurora | stormy time aurora |
|-------------------------------|-------------|---------------|--------------------|
| (a) yellow-greenish | 98 | 64 | 52 |
| (b) red lower border | 0 | 32 | 24 |
| (c) entirely red or upper red | 0 | 3 | 39 |
| (d) others | 2 | 1 | 3 |

From Table 1 one may say that red lower border is characteristic of strong aurora and entirely red or upper part red is characteristic of stormy time aurora. These relations are verified also by Figures 9a and 9b. Figure 9a shows a good correlation between the strong aurora and the aurora with red lower border (dashed line) or pulsating aurora (dotted

line). Figure 9b also shows a fine correlation between the stormy time aurora (full line) and the upper part red aurora (dashed line) or entirely red aurora (dotted line).

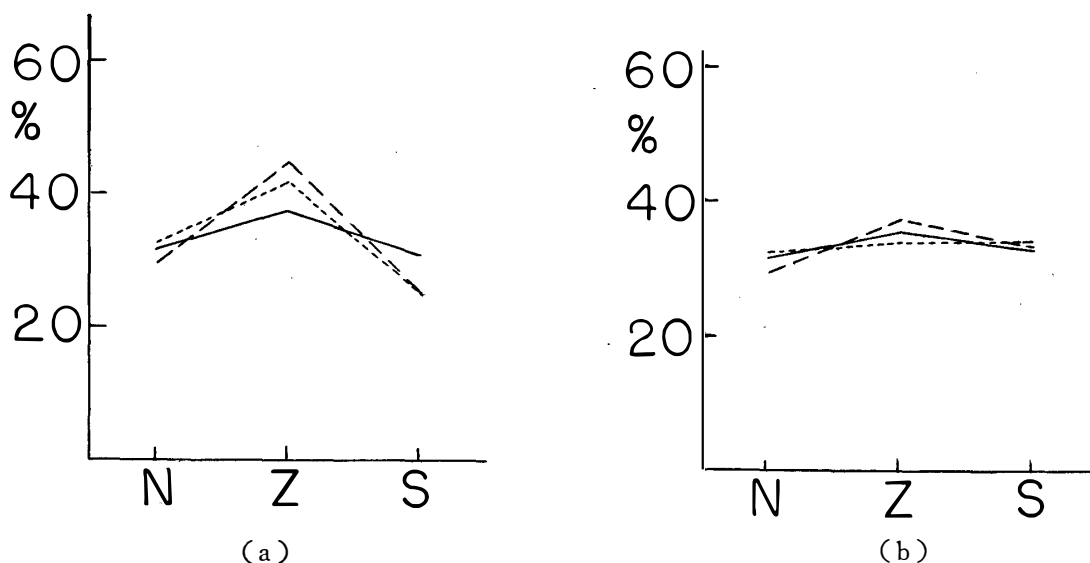

Fig. 9.

- a) Percentage frequency of appearance of strong aurora (full-line), aurora with red lower border (dashed line) and pulsating aurora (dotted line).
 b) Percentage frequency of appearance of stormy time aurora (full-line), upper part red aurora (dashed line) and entirely red aurora (dotted line).

In Table 2 statistics with type are shown.

Table 2.

| | Sunlit | S | G | DS | HA | HB | RA | RB | C | D | R |
|--------------------|--------|------|-----|------|------|------|------|------|-----|------|------|
| weak aurora | 0.25 | 3.1 | 8.9 | 10.3 | 28.8 | 11.2 | 8.5 | 18.4 | 0.0 | 0.05 | 10.5 |
| strong aurora | 0.07 | 0.55 | 0.0 | 1.6 | 10.6 | 8.3 | 10.5 | 61.0 | 2.9 | 2.9 | 1.5 |
| stormy time aurora | 0.40 | 2.0 | 0.0 | 0.4 | 11.7 | 11.7 | 14.2 | 51.0 | 5.5 | 2.2 | 1.4 |

It is clear that most of weak aurora belong to the homogeneous type (62.3%), while strong aurora to ray type (77.3%). Stormy time aurora belongs to the intermediate type, that is, the red part shows in most case homogeneous surface and the yellow-greenish part have ray structure.

4. Spectra of aurorae

We used the Meinel type patrol spectrograph was for automatic photographing the spectra of aurora formed along a given magnetic meridian of the sky from horizon to horizon. Figure 10 shows photographs of the spectrograph set at Syowa Base, with its head exposed to the sky on a roof of our base (Fig. 10a) and the body is set in the laboratory through the roof panel (Fig. 10b).

Figure 11a shows the optical layout of the fish-eye lens, slits, the collimator, grating and camera. Collimator is a 3 inch, f:8 achromatic doublet. The transmission grating has a ruled area of 3 inch square; it is ruled with 15,000 lines to the inch. The grating

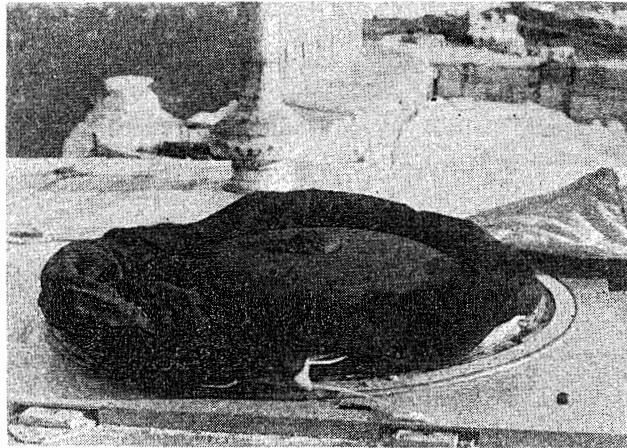

(a)

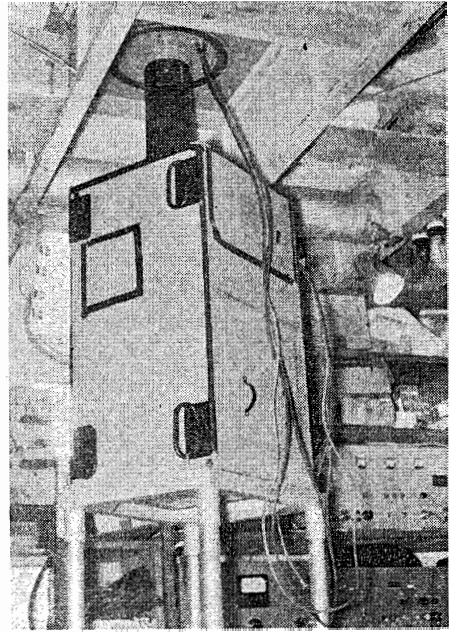

(b)

Fig. 10.

- a) Head of the spectrograph set on the roof of our observation hut.
- b) Body of the spectrograph is set in a hut with other electronic apparatus.

(a)

(b)

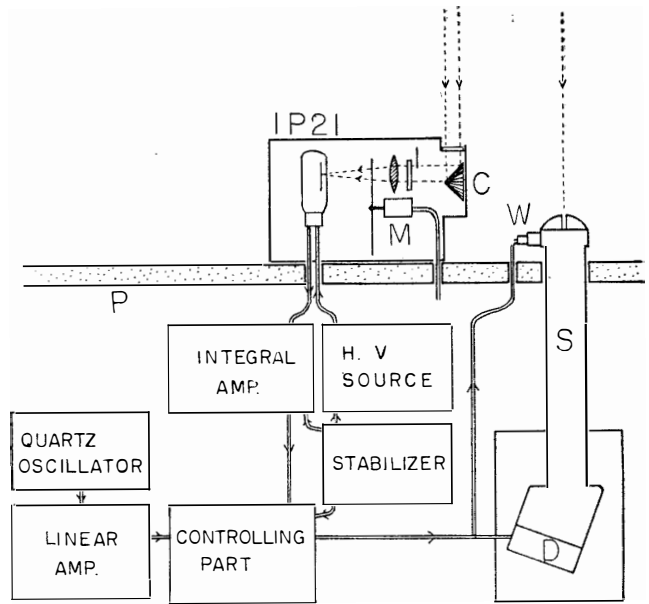
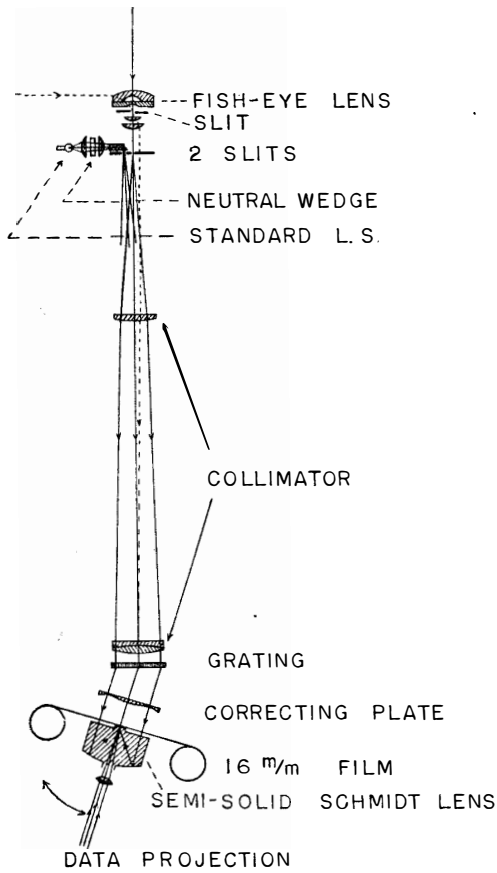

- S: Spectrograph.
- W: Wedge and shutter part.
- D: Data part containing the counters to record time, exposure number and photon counts.
- C: Conical mirror.
- I: Interference filter for λ 5577.
- M: Chopper motor to intercept the radiation which make great enough the signal-to-noise ratio.
- IP 21: RCA photomultiplier.
- P: Roof panel.

Fig. 11. Schematic diagram of optical system and automatic mechanism of the spectrograph.

- a) Optical system of the spectrograph.
- b) Automatic mechanism of the spectrograph.

is to be blazed for the first order and was used to cover two ranges, $\lambda 3400 \sim \lambda 6800$ and $\lambda 5400 \sim \lambda 8800$. A semi-solid Schmidt camera was used both for its speed and insensitivity to variation in focal properties with the temperature change. This camera operated at $f:0.8$.

There are two parallel slits. One is for sky exposure to record the auroral spectrum of a $2^\circ \times 180^\circ$ strip, and the other for exposing the film to the neutral step wedge. Rotary solenoids control two shutters, and during sky exposures only the sky shutter solenoid is energized, while during wedge exposures only the wedge shutter solenoid is energized. The step wedge is mounted on the prism, and is illuminated by a standard light source through the optical system shown in Fig. 11a.

Figure 11b shows the schematic diagram of the exposure monitors. Conical mirror monitors the same area of the sky. Brightness at $\lambda 5577$ of this area enters into 1P21 photomultiplier. A.C. photocurrent is amplified and is charged up to the stylol condenser in the integral amplifier. When the voltage of the condenser is over the present value, discharge current flows to controlling part and the sky exposure terminates automatically. Each group of data consists of four frames; one is a sky exposure and the other three are data recording cycle. The sky recording part of the cycle may last for about few minutes or an hour, the data recording portion always requires eight seconds. When the sky exposures terminates, the data recording cycle begins. And data accumulated on three counter dials, the time in minutes, exposure number and the integrated exposure intensity are imaged on the film through a clear area of the spherical Schmidt reflecting surface. The time is controlled by the quartz oscillator of the precision 10^{-4} . On the second frame of the data recording cycle a calibrated neutral wedge is photographed (Fig. 11a). The third frame is left blank. At the end of the cycle the spectrograph is restored to its primary function, recording the auroral spectrum.

In our spectrograph, radiation from $2^\circ \times 180^\circ$ sky along the geomagnetic meridian was imaged on the second slit. Accordingly, the ends of each spectral line corresponded to the horizon of the geomagnetic north or south and the centre of the line corresponded to the zenith.

A few examples of spectra are shown in Figure 12. As stated above, aurora is classified into three types: (a) yellow-greenish, (b) red lower border and (c) upper part red or entirely red. According to this classification, it became obvious that the characteristic of the spectra of (a) type aurora was only having a $\lambda 5577$ OI line and negative group bands of N_2^+ ; (b) type is characterized by the appearance of the first positive group and the second positive group of N_2 ; (c) type shows the enhancement of $\lambda 6300$ and $\lambda 6363$ OI lines relative to $\lambda 5577$ OI line. Spectra of (c1), (c2) and (c3) are photographed by long wave length range of $\lambda 5400 \sim \lambda 8800$. We used the Kodak 103aF 16 mm film which is sensitized to about $\lambda 7000$, and the spectra seen at $\lambda 7830$ region correspond to the second order of N. G. (0,0) band. $\lambda 5577$ line and N. G. are also found in (b) and (c) types. H_α or H_β line can be seen often in (b) and (c).

Generally speaking, directional distributions are different by respective auroral type;

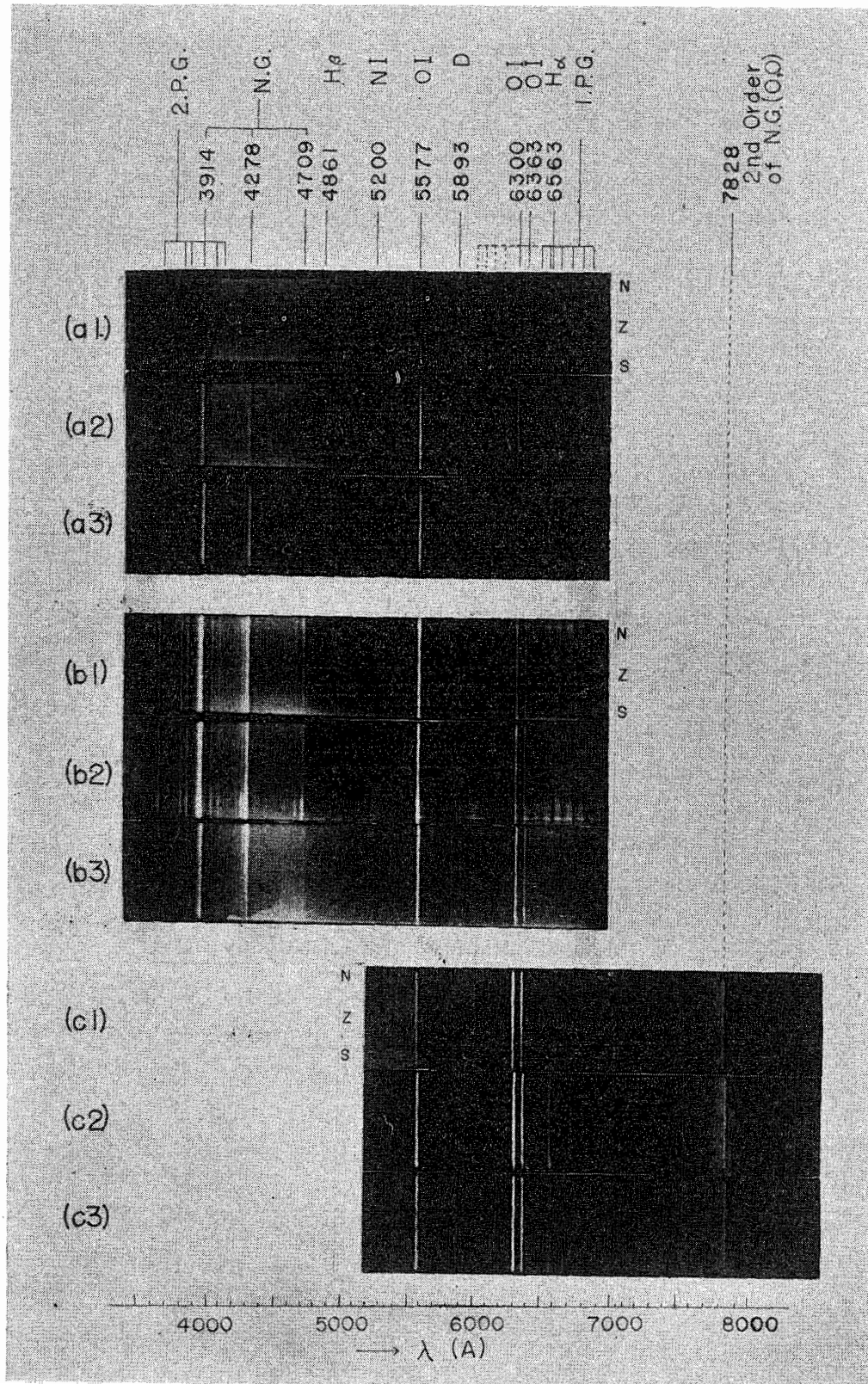

Fig. 12. Examples of auroral spectra.

- a) Spectra of yellow-greenish aurora (λ 3400- λ 6800).
 (a1) 1959 May 20/21 17:04-17:23 U. T. (a2) 1959 May 20/21 18:38-18:56 U. T.
 (a3) 1959 May 20/21 20:15-20:18 U. T.
- b) Spectra of aurora with red lower border (λ 3400- λ 6800).
 (b1) 1959 March 2/3 20:00-20:10 U. T. (b2) 1959 March 2/3 20:10-20:18 U. T.
 (b3) 1959 March 2/3 21:30-22:09 U. T.
- c) Spectra of red aurora (λ 5400- λ 8800).
 (c1) 1959 July 15/16 14:00-14:05 U. T. (c2) 1959 July 15/16 14:16-14:22 U. T.
 (c3) 1959 July 15/16 14:32-14:38 U. T.

as seen from (a1), (a2) and (a3), (a) type aurora first appeared in the southern horizon and inclined to move slowly to the north; (b) type did not show any constant directional movement at Syowa Base. As an example in Fig. 12 showed, this active aurora moved first from north to south (b1 and b2), and then returned to north (b2 and b3). (c) type seemed to move from north to south slowly (c1, c2 and c3).

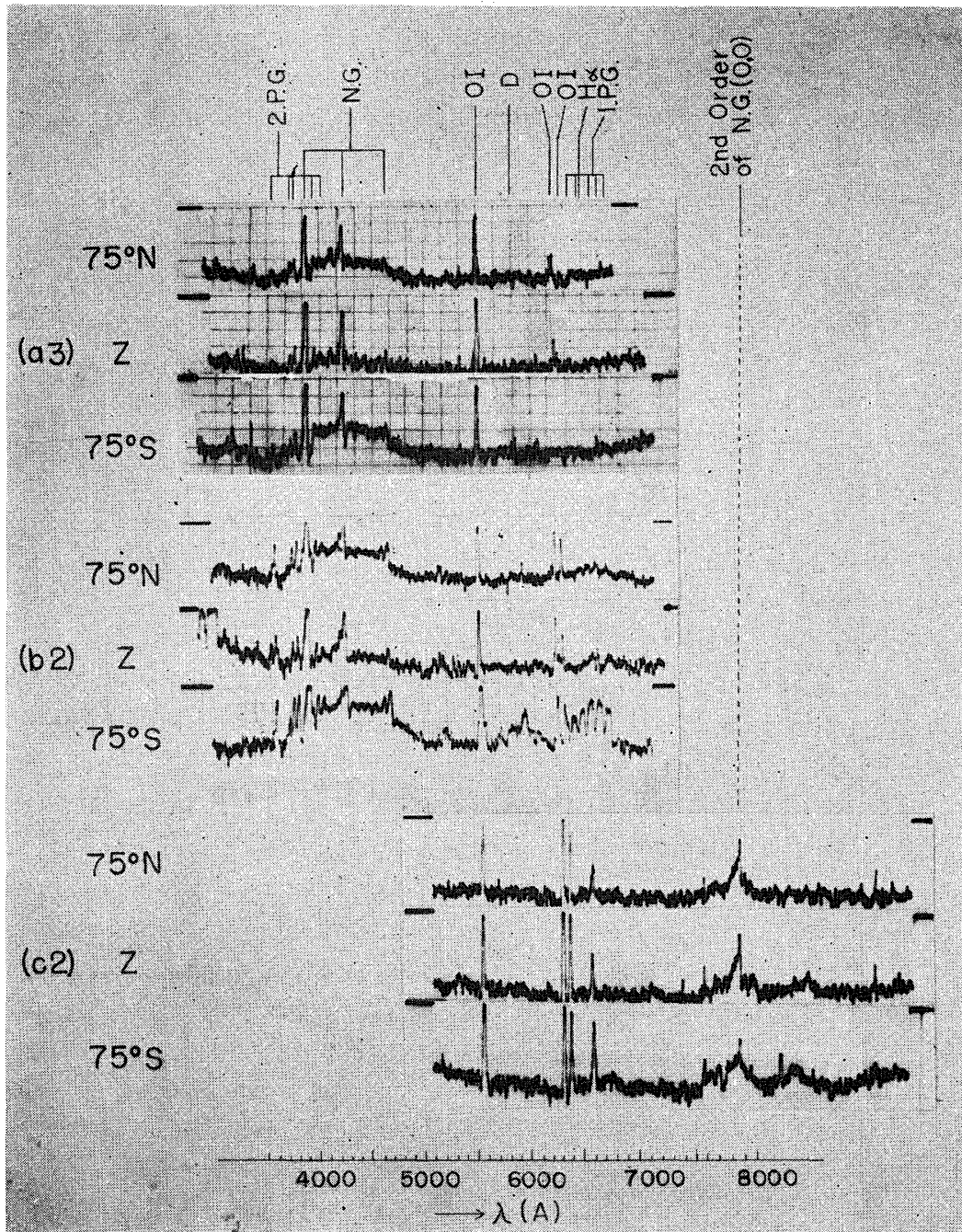

Fig. 13. Results of microphotometry of auroral spectra corresponding to Fig. 12.

(a3) 1959 May 20/21 20:15-20:18.

(b2) 1959 March 2/3 20:10-20:18.

(c2) 1959 July 15/16 14:16-14:22.

Figure 13 shows the results of photometry of the spectra of (a3), (b2) and (c2) in Fig. 12. These show the range of emission layer of each type aurora with their

characteristics. (a) and (b) types appear in a comparatively narrow space, while (c) type is distributed throughout the whole sky. This is one of the reasons why we consider difference in emission mechanism between (a) (b) and (c) types.

5. Discussions and conclusion

It has been stated so far that aurora can be classified into three types each of which having spectroscopic characteristics corresponding to different emission mechanisms. Parallaxic photographing performed between Syowa Base and Skjegget at Skarvsnes ($69^{\circ}24'S$, $39^{\circ}40'E$) showed that the height of lower edge of the (a) type aurora was about 100 km⁵⁾. On the other hand, the red lower border of (b) type aurora is considered about 80 km high. Height of the emission layer of red part in the (c) type aurora will be about 200 km or 300 km, for this layer always lies above the yellow-greenish 100 km layer, and moreover there is intimate relations between (c) type aurora and ionospheric F layer.

(a) type appears in the evening and lasts to midnight, and seems to correspond to magnetic positive bay disturbance, which turns to more active (b) type aurora frequently⁶⁾. Type (b) seems to correspond to negative bay disturbance⁸⁾. Type (c) seems to have no local time dependency and have origin somewhat different from (a) or (b) type. This is considered as the so-called monochromatic low latitude aurora⁷⁾ and corresponds to world wide magnetic storms.

Speaking of auroral zone, it is not always fixed to one position, but changes its position by local time. Upper atmospheric ring current formed by positive bay disturbance in the evening will spread to lower latitude which correspond to the south-to-north movement of (a) type aurora. Heavier current system caused by negative bay disturbance may explain the movement of (b) type aurora about midnight. In stormy time the current system which corresponds to the inner VAN ALLEN belt is formed in lower latitudes. Such current system will diffuse to higher latitudes slowly which seems to correspond to the slow movement of (c) type aurora from north to south. Of course many exceptional cases can be seen which makes the movement of aurora complicated.

Considering these facts it is more rational to define the position of the auroral maximum zone by respective auroral types for examination of the relation between auroral zone and other quantities or phenomenon in the upper atmosphere; the energy of incident particles, the position of the VAN ALLEN belt⁹⁾, inner auroral zone⁹⁾, etc.

It is concluded that in Syowa Base weak yellow-greenish aurora appears most frequently south of the base in the evening. It will turn into strong red lower border aurora about midnight overhead or in the vicinity. While, the upper part red or entirely red aurora corresponding to monochromatic aurora appears at stormy time just north of our base. Judging from their spectra, these three types of aurora may be luminescent due to the respectively different emission mechanisms.

Acknowledgements

First the author wishes to express his hearty thanks to Prof. M. HURUHATA for constant encouragement and discussions to this work. He also express his profound gratitude to Prof. T. NAGATA who was the leader of III JARE and cotrolled the aeronomy observations. Mr. T. KITAMURA cooperated in the auroral observation at Syowa Base in 1959 to whom the author is greatly indebted. He also thanks to the colleagues at Syowa Base for many geophysical data rendered to him. In preparing apparatus Mr. T. NAKAMURA and Mr. H. TANABE at Tokyo Astronomical Observatory gave much aid which the author appreciates very much.

References

- 1) F. R. Bond and F. Jacka (1960): Austr. J. Phy., **13** No 3.
- 2) E. H. Vestine and E. J. Snyder (1945): Terr. Mag., **50** 105.
- 3) W. Stoffregen (1959): Instructions for Scaling Auroral Ascaplots and Auroral Indics, Upsala.
- 4) D. M. Hunten, F. E. Roach and J. W. Chamberlain (1956): J. A. & T. Phys., **8**, 345.
- 5) L. Harang (1951): The Aurorae, Chapman & Hall.
- 6) M. Gadsden (1959): Ann. de Geophys., **15** 395. F. R. Bond (1960): Aust. J. Phys., **13** No. 3.
- 7) F. E. Roach and E. Marovich (1959): J. Res. of NBS, **63D** 297 & **64D** 205.
B. J. O'Brien, J. A. Van Allen, F. E. Roach and C. W. Gartlein (1960): J. Geophys. Res., **65** 2759.
- 8) J. A. Van Allen, C. E. McIlwain and G. H. Ludwig (1959): J. Geophys. Res., **64** 271.
- 9) K. Lassen (1959): Nature, **4696** 1375.

(Received Feb. 1, 1961)