

# UPPER ATMOSPHERE PHYSICS DATA OBTAINED AT SYOWA STATION IN 1997

Satoshi TAKEUCHI<sup>1</sup>, Takashi OOKAWA<sup>2</sup>, Tadashi SETOGUCHI<sup>3</sup>,  
Jun OZEKI<sup>3</sup>, Masayuki KIKUCHI<sup>4</sup>, Akira KADOKURA<sup>4</sup> and Makoto TAGUCHI<sup>4</sup>

<sup>1</sup>*Yamanashi University, Kofu-shi, Yamanashi 400-8511*

<sup>2</sup>*Kakioka Magnetic Observatory, Niihari-gun Yasato-machi, Ibaraki 315-0116*

<sup>3</sup>*Communications Research Laboratory, Koganei-shi, Tokyo 184-8795*

<sup>4</sup>*National Institute of Polar Research, Itabashi-ku, Tokyo 173-8515*

## 1. Introduction

This data book summarizes upper atmosphere physics data acquired by the 38th Japanese Antarctic Research Expedition (JARE-38) with the "Upper Atmosphere Physics Monitoring (UAPM) System" at Syowa Station in 1997. Observation items are as follows:

- 1) Geomagnetism :
  - H-, D- and Z-components of magnetic variations
  - Total force of the geomagnetic field
  - H-, D- and Z-components of magnetic pulsations
- 2) ELF-VLF wave :
  - Intensities at 0.35, 0.75, 1.2, 2, 4, 8, 30, 60 and 95 kHz
  - Wide-band (0-10 kHz) signal of ELF-VLF emissions
- 3) Ionosphere :
  - Cosmic noise absorption at 30 MHz observed with a broad-beam riometer
- 4) Aurora :
  - All-sky cameras :
    - Film type : Panchromatic images recorded on color films
  - Scanning photometers :
    - Meridian-scanning record at the following three wavelengths  
557.7 nm (OI), 630.0 nm (OI) and 486.1 nm (H $\beta$ )

An outline of the observation system is given in Section 2. Section 3 describes specifications of the observation instruments and the data acquisition systems. Observation periods are also listed in Section 3. Format of the compiled digital data is shown in Section 4. Summary plots in the period of January 1-December 31, 1997 are given in Appendix.

All-sky camera observation data, magnetograms and summary plots of the monitoring data are available to users on request. The request should be addressed to:

World Data Center C2 for Aurora

National Institute of Polar Research  
9-10, Kaga 1-chome, Itabashi-ku,  
Tokyo 173-8515, Japan.

Digital and analog data described here are available to researchers who will do collaborative studies with the upper atmosphere physics group of NIPR. The request should be addressed to:

Upper Atmosphere Physics Research Division  
National Institute of Polar Research  
9-10, Kaga 1-chome, Itabashi-ku,  
Tokyo 173-8515, Japan.

## 2. Upper Atmosphere Physics Monitoring (UAPM) System

A real-time digital data acquisition system for upper atmosphere physics observation was constructed at Syowa Station in January 1981 (Sato *et al.*, 1984). Data obtained from the system have been collected and published annually in the JARE Data Reports (Upper Atmosphere Physics) (Sato *et al.*, 1984, 1991 ; Fujii *et al.*, 1985, 1994; Sakurai *et al.*, 1985; Ono *et al.*, 1986, 1993; Yamagishi *et al.*, 1987; Kikuchi *et al.*, 1988; Miyaoka *et al.*, 1990; Kadokura *et al.*, 1992; Yamazaki *et al.*, 1995; Tonegawa *et al.*, 1996; Obara *et al.*, 1996; Arisawa *et al.*, 1997; Kawana *et al.*, 1998). This report is the 17th of this series.

A block diagram of the system, including other ground observations, is shown in Fig. 1. The sensors for measuring weak natural electromagnetic waves such as ELF-VLF emissions, the three components of ULF magnetic pulsations and cosmic radio noise absorption (CNA) have been placed at a remote station on West Ongul Island, located about 5 km from Syowa Station in order to avoid man-made electromagnetic interference. Data of the magnetic pulsations and CNA are transmitted continuously to Syowa Station by a PCM telemeter in VHF band. Wide-band signals of ELF-VLF emissions are transmitted to Syowa Station through an FM telemeter in UHF band.

At the remote station, the electric power which drives all the instruments has been supplied by a solar battery system with maximum output power of 530 W since February 1985. An additional solar battery system with maximum power of 365 W was installed in January 1987 to reinforce the original battery system. The solar battery system consists of eighteen rechargeable car batteries (200 Ah each), five solar panels and three controllers in total. During winter when no sunlight is available, these batteries are charged manually about once a month by using a 10 kVA diesel-engine dynamo, which was installed in 1992 instead of the previous 16 kVA one.

The fluxgate and proton magnetometer sensors are placed at Syowa Station on East Ongul Island, about 150 m apart from the Data Processing Building. All the auroral photometric instruments are placed on the roof of the building, and the data acquisition facilities are installed

inside the building. All the outputs obtained from the observation instruments except the auroral photometric ones are transferred to the matrix terminal board and then recorded with pen recorders, analog data recorders and a computer system. These data have been recorded simultaneously with two sets of the TEAC DR-200 digital data logger systems since January 1987 and with the Accurate Timing data Logging and Analysis support System (ATLAS) since February 1997. An 8 mm video tape recorder is used to record wide-band VLF emissions, and 24-hour data can be stored on one volume of 8 mm video tape.

Universal time (UT) is supplied from a precise time-keeping system. This system consists of a GPS satellite timing receiver, a quartz frequency standard with a stability of  $2 \times 10^{-11}$ /day, and time code generators. The time code generators supply the IRIG-A, -B and slow codes for analog data recorders and the 36-bit BCD code for the digital recording systems, respectively. The absolute accuracy of this system is estimated to be about 1 ms.

### 3. Specifications of Instruments

#### 3.1. Geomagnetism

##### (1) *Magnetogram*

Magnetic variations were measured by a three-axis fluxgate magnetometer. Full scale ranges were +1250 to -3750 nT for H-component and  $\pm 2500$  nT for D- and Z- components, respectively, with the frequency response of DC–2 Hz and noise levels less than 0.5 nT. The magnetometer data were recorded in digital form at the sampling rate of 1 Hz. The H-component data were also recorded on a chart recorder and an R-950L long-term analog data recorder.

##### (2) *Total force of the geomagnetic field*

Due to the prolonged trouble with the proton magnetometer since January 1991, the total force observations were made only about once per month in 1996, using the other portable proton magnetometer, which was unable to be linked with the UAPM system. The results are listed in Table 1.

##### (3) *ULF magnetic pulsations*

The H-, D-, and Z-components of ULF magnetic pulsations are detected by three sets of search coil magnetometers. The search coil sensors have copper wires (0.4 mm $\phi$ , 40000 turns each) wound around permalloy cores (1 cm in diameter  $\times$  100 cm in length). Measurable intensity range of the magnetometer is 0.001–5 nT/s and the frequency response is 0.001–3 Hz. The search coil magnetometers are installed at the remote station on West Ongul Island. The output signals transmitted by the PCM telemeter are recorded on a chart recorder and a digital data recorder. The sampling frequency of the digital data is 10 Hz and 1 Hz for each component.

##### (4) *Base line of the magnetic field and K-index*

Base line values of the magnetic field were observed about once or twice per month during a magnetically quiet day. K-indices are calculated for every 3-hour interval measuring the amplitudes of the H- and D-component magnetic fields from the quiet-day variations. The definition of the K-indices at Syowa Station is as follows:

<u>K-index</u>	<u>Deviation</u>	<u>K-index</u>	<u>Deviation</u>
0	: 0 – 25 nT	5	: 350 – 600 nT
1	: 25 – 50	6	: 600 – 1000
2	: 50 – 100	7	: 1000 – 1660
3	: 100 – 200	8	: 1660 – 2500
4	: 200 – 350	9	: 2500 and more

The ordinary magnetogram is also available on chart papers with a recording speed of 5 cm/hr. The sensitivity of each component on the chart papers is about 100 nT/cm. Table 2 gives the baseline values and K-indices at Syowa Station in February 1997 – January 1998. Inquiries or requests for the data copies of the magnetic field measurements should be addressed to World Data Center C2 for Aurora in NIPR.

### 3.2. ELF-VLF waves

The natural ELF-VLF wave receiving system at the remote station has consisted of a triangle-shaped three turn loop antenna (10 m in height, 20 m in the bottom side), a pre-amplifier and a main amplifier with gains of 60 and 40 dB, respectively. The ELF-VLF wave intensities at the frequency bands of 0.35, 0.75, 1.2, 2, 4, 8, 30, 60, 95 kHz were obtained from wide band waveforms using a 9-channel filter bank and detectors. The ELF-VLF emissions within the intensity range of  $10^{-17}$  to  $10^{-13}$  W/m<sup>2</sup> Hz were detectable with this system. These data were recorded continuously in digital form at the sampling rate of 1 or 10 Hz. Some of the wide-band ELF-VLF signals up to 10 kHz were recorded on 8 mm video tape recorders. The wide-band recording was executed during 900 - 1300 UT on Sunday - Friday.

### 3.3. Ionosphere

Cosmic noise absorption at 30 MHz was observed with a broad-beam riometer, which has been installed at the remote station on West Ongul Island since 1981. Its beam half-width is 60°. Used receiver is made by La Jolla Science, and bandwidth and time constant are 150 kHz and 0.25 s, respectively. The riometer data were recorded in digital form at the sampling rate of 1 Hz in the UAPM system.

Data of ionospheric vertical sounders, broad-beam riometers (20 and 30 MHz), HF field strength receivers (8 and 10 MHz) and the VHF auroral radar (50 and 112 MHz) were recorded with other observation systems at Syowa Station, and the observational results have been published in another JARE Data Report (Ionosphere). Inquiries and requests for the data copies are to be

addressed to:

World Data Center C2 for Ionosphere  
Communications Research Laboratory  
Ministry of Posts and Telecommunications  
2-1, Nukui-Kitamachi 4-chome, Koganei-shi,  
Tokyo 184-8795, Japan.

### 3.4. Aurora

#### (1) *All-sky camera*

All-sky observation of aurora was made by traditional film-type camera with a fish-eye lens of 8 mm F2.8. KODAK-EASTMAN 5226, ISO-500, 400 ft, 35 mm color films were used. An observation list for the film-type is given in Table 3. Inquiries or requests for the all-sky data should be addressed to World Data Center C2 for Aurora in NIPR.

#### (2) *Meridian-scanning photometer*

Auroral emissions at the wavelengths of 557.7 nm (OI), 630.0 nm (OI) and 486.1 nm (H $\beta$ ) were observed by a meridian-scanning photometer installed in 1987. The interference filter for H $\beta$  was tilted with 1 s period, measuring the Doppler effect of the auroral H $\beta$  emission. The field of view of the photometer is 3° for OI 557.7 nm and 630.0 nm, and 5° for H $\beta$ . A scan along a meridian from the poleward horizon to the equatorward horizon requires 30 s. Observations were carried out during 107 clear nights from March 14 until October 15 in 1996. Calibration using a standard light source was executed at every observation night. The meridian-scanning photometer data were recorded with a digital data logger (TEAC DR-200) at a sampling frequency of 10-25 Hz through a line-approximate logarithmic amplifier, and monitored with a pen-recorder (6 ch RECTI-GRAPH). Due to a trouble in the instrument, both scanning and tilting angle data were not recorded.

## 4. Compiled Digital Data Format

### (1) *Magnetic Tape*

Data have been digitally recorded continuously since 1981. A similar recording system has been used in Iceland for the geomagnetic conjugate observations. The specifications of the compiled digital tapes are as follows:

Tracks	:	9
Record density	:	6250 BPI
Record format	:	FB
Block length	:	28848 bytes

Logical record length : 48 bytes  
 Label : Non-label  
 Filing : Multi-file (1 file/day)

24 kinds of upper atmospheric data are recorded every 1 s in the following sequence:

<u>Word No.</u>	<u>Observation item</u>	<u>Word No.</u>	<u>Observation item</u>
1	H-component of geomagnetic field	13	VLF 8 kHz
2	D-component of geomagnetic field	14	VLF 30 kHz
3	Z-component of geomagnetic field	15	VLF 60 kHz
4	H-component of ULF waves	16	VLF 95 kHz
5	D-component of ULF waves	17	NA
6	Z-component of ULF waves	18	NA
7	CNA (30 MHz)	19	NA
8	VLF 350 Hz	20	NA
9	VLF 750 Hz	21	NA
10	VLF 1.2 kHz	22	NA
11	VLF 2 kHz	23	NA
12	VLF 4 kHz	24	NA

Words 17-24 are dummy words. Each word, 12 bit A/D converted value, is recorded in the 2 byte binary form of signed 2's complement. A set of these 24 words makes a logical record of 48 bytes; the 10-min data make a block of 28848 bytes. A file contains one day of data (144 blocks) and a volume contains one month of data (28-31 files), as shown in Fig. 2. At the beginning of each block, the starting time of the observation period is written in the following format (48 bytes):

<u>Sequence</u>	<u>Item</u>	
1	Year	(2 bytes)
2	Total day	(2 bytes)
3	Hour	(2 bytes)
4	Minute	(2 bytes)
5	Station code	(4 bytes)
6	Space	(36 bytes)

The magnetic field data recorded on a compiled tape can be transformed to physical quantities by the following relations:

$$\begin{aligned} \text{H-component of the geomagnetic field variation (nT)} &= \text{DATA} * 2500 / 2048 - 1250 \\ \text{D- and Z-component of the geomagnetic field variation (nT)} &= \text{DATA} * 2500 / 2048 \end{aligned}$$

H-component of ULF waves (nT/s)	= DATA/141
D-component of ULF waves (nT/s)	= DATA/158
Z-component of ULF waves (nT/s)	= DATA/316

For CNA and VLF data, individual calibration values are required to obtain physical values from the recorded data. Inquiries on these calibration values should be addressed to the Upper Atmosphere Physics Research Division of NIPR. For more detailed information on the compiled data, see Uchida *et al.* (1988). These compiled data are also recorded on an Optical Disk (OD) at the sampling rate of 0.5 Hz together with the data from three Icelandic stations for conjugate studies. One volume of the OD can store the data obtained at the four stations during one year. Softwares to handle the OD data are also available to researchers. Details of the OD conjugate data base are described in Yamagishi (1990).

A computer system of the Information Science Center is available to collaborative researchers of NIPR. The center has also been providing various kinds of software such as tape-to-tape copy, displays and spectrum analysis program to the researchers.

## (2) *Magnetic Optical Disc*

MO media has been added since 1998 recorded by ATLAS (AT compatible computer with QNX operating system). This system has GPS clock and 16bit strait binary A/D converter (from  $-10V$  to  $10V$ ). Data in MO are written by Common Data Format (CDF) based on NASA NSSDC (see [1] or [2] for more detail of CDF). Each record has one time stamp and 16 kinds of data. Variable names of CDF for each data are follows;

- EPOCH: Time stamp (unit: CDF Epoch)
- MGFH: H component of flux gate magnet meter
- MGFD: D component of flux gate magnet meter
- MGFZ: Z component of flux gate magnet meter
- ULFH: H component of induction coil
- ULFD: D component of induction coil
- ULFZ: Z component of induction coil
- CAN: CNA
- VLF350: Intensity of natural VLF wave at 350Hz
- VLF750: Intensity of natural VLF wave at 750Hz
- VLF1.2k: Intensity of natural VLF wave at 1.2kHz
- VLF2.0k: Intensity of natural VLF wave at 2.0kHz
- VLF4.0k: Intensity of natural VLF wave at 4.0kHz
- VLF8.0k: Intensity of natural VLF wave at 8.0kHz
- VLF30k: Intensity of natural VLF wave at 30kHz
- VLF60k: Intensity of natural VLF wave at 60kHz
- VLF95k: Intensity of natural VLF wave at 95kHz.

Each CDF valuable has 5 attributes. The names of attributes and characteristics are follows;

Attributes (based on CDF standard attribute name)

VALIDMIN: Minimum valid value of raw AD data (usually, 0).

VALIDMAX: Maximum valid value of raw AD data (usually, 65534)

SCALEMIN: Minimum value as unit for VALIDMIN

SCALEMAX: Maximum value as unit for VALIDMAX

UNIT: Unit (ex. nT, V/mHz, dB: written by characters)

Using these valuables, user can convert from A/D value to physical value following relation.

$$\begin{aligned} \text{(Physical value)} = & \text{SCALEMIN} + \\ & \frac{(\text{SCALEMAX}-\text{SCALEMIN})}{(\text{VALIDMAX}-\text{VALIDMIN})} * \\ & ((\text{Variable data})-\text{VALIDMIN}) \end{aligned}$$

[1] CDF User's Guide (Version2.6) NASA/GSFC/NSSDC,

[2] [http://nssdc.gsfc.nasa.gov/cdf/cdf\\_home.html](http://nssdc.gsfc.nasa.gov/cdf/cdf_home.html)

## Acknowledgments

We would like to acknowledge all the members of the 38th Japanese Antarctic Research Expedition (JARE-38) for their support to the upper atmosphere physics observations at Syowa Station. The publication of this report was supported by the Upper Atmosphere Physics Research Division, WDC-C2 for Aurora and the Information Science Center of the National Institute of Polar Research.

## References

- Arisawa, T., Kato, Y., Otaka, K., Inamori, Y., Kaneko, M. and Taguchi, M. (1997): Upper atmosphere physics data obtained at Syowa Station in 1995. JARE Data Rep., **225** (Upper Atmos. Phys.15), 204p.
- Fujii, R., Sato, N. and Fukunishi, H. (1985): Upper atmosphere physics data, Syowa Station, 1982. JARE Data Rep., **105** (Upper Atmos. Phys. 2), 266p.
- Fujii, R., Kotake, N., Murata, I., Nozaki, K., Umetsu, M., Makita, K., Minatoya, H. and Yukimatu, A. (1994): Upper atmosphere physics (UAP) data obtained at Syowa and Asuka Stations in 1991. JARE Data Rep., **193** (Upper Atmos. Phys. 11), 208p.
- Kadokura, A., Uchida, K., Kurihara, N., Kimura, K., Okamura, H., Ariyoshi, H., Yukimatsu, A. and Ejiri, M. (1992): Upper atmosphere physics data, Syowa and Asuka Stations, 1989. JARE Data Rep., 171 (Upper Atmos. Phys. 9), 335p.
- Kawana, S., Kikuchi, M., Sakanoi, T., Yumisashi, I. and Taguchi, M. (1998): Upper atmosphere physics data obtained at Syowa Station in 1996. JARE Data Rep., **233** (Upper Atmos. Phys.16), 202p.



- Kikuchi, T., Ohwada, T., Oginasa, T., Uchida, K., Sakurai, H., Yamagishi, H. and Sato, N. (1988): Upper atmosphere physics data, Syowa Station, 1986. JARE Data Rep., **138** (Upper Atmos. Phys. 6), 276p.
- Miyaoka, H., Uchida, K., Mukai, H., Saito, H., Akamatsu, J., Shibuya, K., Sakai, R., Ayukawa, M. and Sato, N. (1990): Upper atmosphere physics data, Syowa and Asuka Stations, 1987. JARE Data Rep., **159** (Upper Atmos. Phys. 7), 306p.
- Obara, N., Wakino, Y., Kubota, M., Iwasaki, K., Nishimura, H. and Kadokura, A. (1996): Upper atmosphere physics data obtained at Syowa Station in 1994. JARE Data Rep., **209** (Upper Atmos. Phys. 14), 208p.
- Ono, T., Tsunomura, S., Ejiri, M., Fujii, R. and Sato, N. (1986): Upper atmosphere physics data, Syowa Station, 1984. JARE Data Rep., **118** (Upper Atmos. Phys. 4), 271p.
- Ono, T., Nakajima, H., Satoh, M., Ohtaka, K., Kawahara, M. and Kumade, A. (1993): Upper atmosphere physics data, Syowa and Asuka Stations, 1990. JARE Data Rep., **186** (Upper Atmos. Phys. 10), 222p.
- Sakurai, H., Shibasaki, K., Fujii, R. and Sato, N. (1985): Upper atmosphere physics data, Syowa Station, 1983. JARE Data Rep., **108** (Upper Atmos. Phys. 3), 212p.
- Sato, N., Fujii, R., Fukunishi, H. and Nakajima, D. (1984): Upper atmosphere physics data, Syowa Station, 1981. JARE Data Rep., **93** (Upper Atmos. Phys. 1), 206p.
- Sato, N., Uchida, K., Saka, O., Yamaguchi, K., Iguchi, S., Aoki, T. and Miyaoka, H. (1991): Upper atmosphere physics data, Syowa and Asuka Stations, 1988. JARE Data Rep., **169** (Upper Atmos. Phys. 8), 212p.
- Tonegawa, Y., Rokuyama, K., Makita, Y., Yang H., Kadokura, A. and Sato, N. (1996): Upper atmosphere physics data obtained at Syowa Station in 1993. JARE Data Rep., **208** (Upper Atmos. Phys. 13), 202p.
- Uchida, K., Tonegawa, Y., Fujii, R. and Sato, N. (1988): Computer compilatory process of the data acquired by the conjugate observation system in Iceland. Nankyoku Shiryo (Antarct. Rec.), **32**, 238-257 (in Japanese with English abstract).
- Yamagishi, H. (1990): Development of Optical Disk data base system for Syowa Station-Iceland geomagnetically conjugate observation. Nankyoku Shiryo (Antarct. Rec.), **34**, 242-262 (in Japanese with English abstract).
- Yamagishi, H., Ayukawa, M., Matsumura, S., Sakurai, H. and Sato, N. (1987): Upper atmosphere physics data, Syowa Station, 1985. JARE Data Rep., **128** (Upper Atmos. Phys. 5), 272p.
- Yamazaki, I., Takahashi, Y., Mineno, H., Kamata, M., Ogawa, Y. and Kadokura, A. (1995): Upper atmosphere physics data obtained at Syowa Stations in 1992. JARE Data Rep., **205** (Upper Atmos. Phys. 12), 207p.

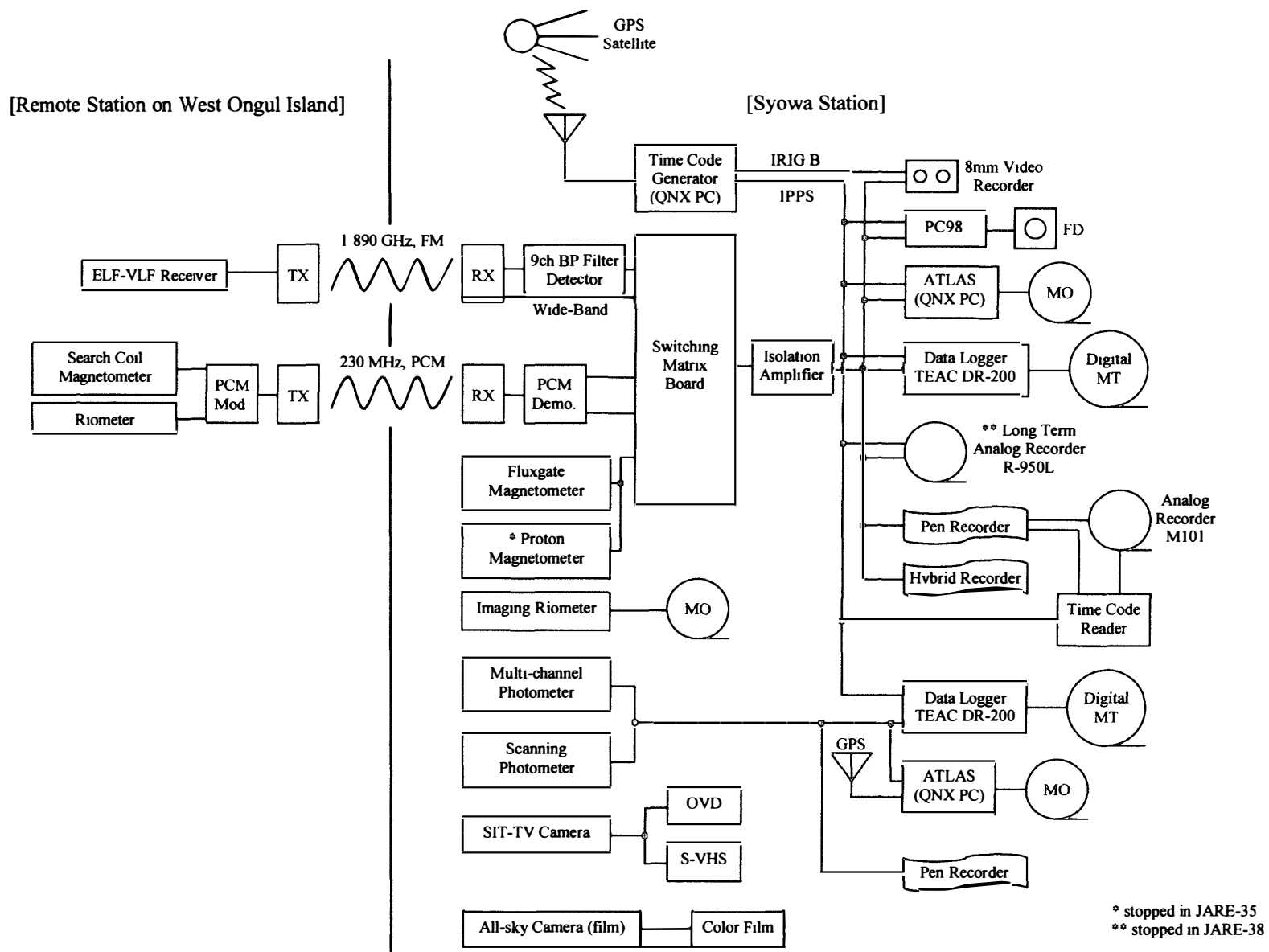

Fig. 1. Block diagram of the "Upper Atmosphere Physics" monitoring system at Syowa Station in 1997.

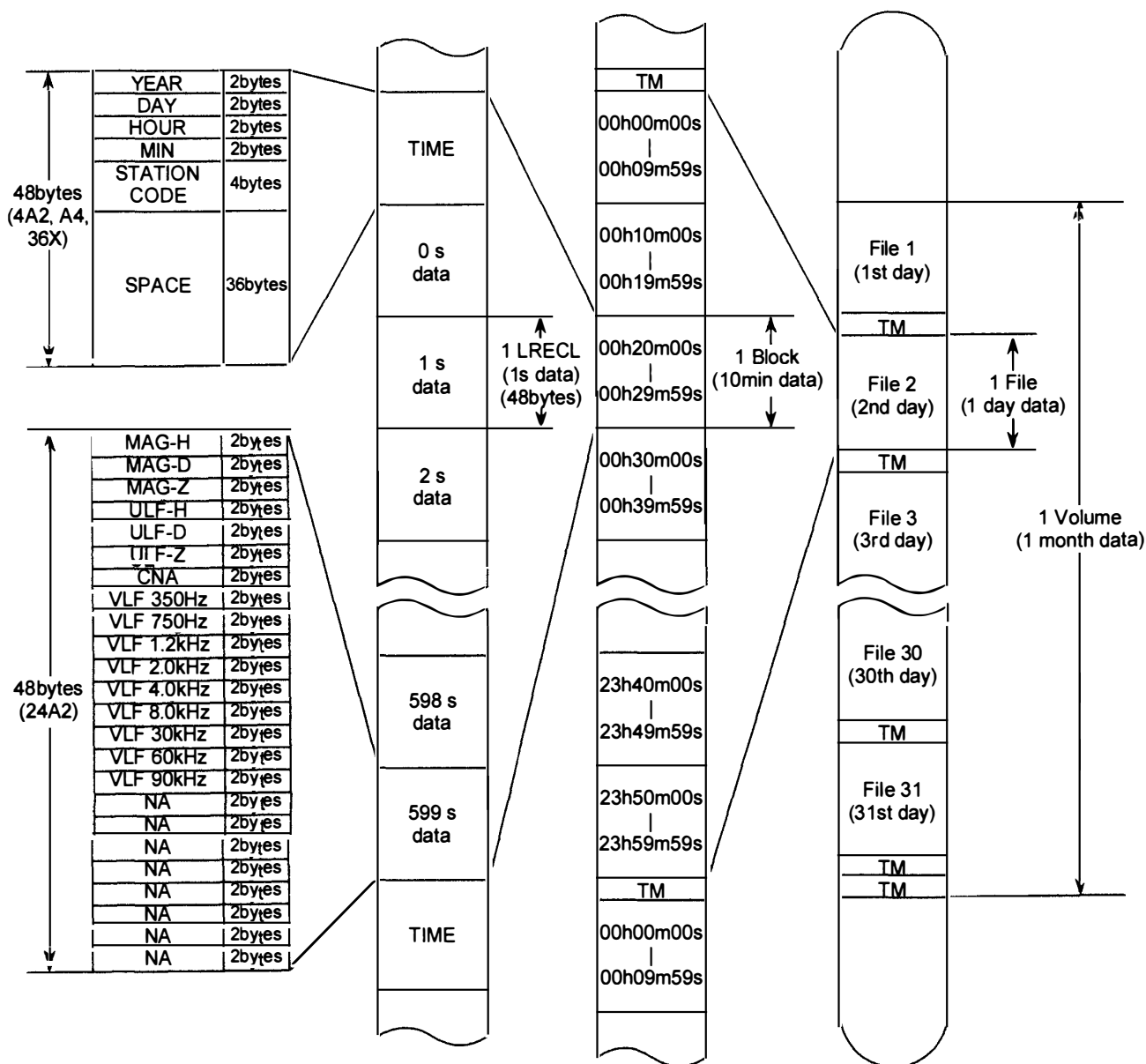

Fig. 2. The structure of the compiled digital tape format for Syowa Station in 1997.

Table 1. Baseline values of the geomagnetic field at Syowa Station in February 1997–January 1998.

DATE	TIME hh mm	DECLINATION (deg min)	TIME hh mm	DIP ANGLE (deg min)	TOTAL (nT)	HORIZONTAL (nT)	VERTICAL (nT)
1997 02/26*	10:59	-47:57.8	10:59	-63 55 5	43539.2	19137.5	-39107.8
	11:13	-47:56.9	11 13	-63 55 2	43545.6	19143.8	-39111.8
	11:32	-47 56 9	11 32	-63 54 6	43547.9	19151.6	-39110.6
	11:40	-47:56.8	11 40	-63:53.9	43563.4	19166.4	-39120.6
	mean	11 18	-47:57.1	11:18	-63 54.8	43549.0	19149.8
1997 03/25*	10 56	-48 00 6	10 56	-63 55 4	43537.4	19137.9	-39105.6
	11 09	-48:01 0	11 09	-63 55 4	43544.9	19141.2	-39112.3
	11:24	-47:59 7	11 24	-63 55 2	43542.4	19142.4	-39109.0
	11:32	-48:00.5	11 32	-63 54 8	43554.5	19152.2	-39117.6
	mean	11:12	-48:00 5	11:12	-63.55.2	43544.8	19143.4
1997 04/29*	10:51	-48:04.4	10:51	-63:53.9	43534.8	19153.8	-39094.9
	11 04	-48 04 5	11:04	-63:54 0	43535.6	19153.0	-39096.2
	11:20	-48:04.4	11:20	-63:53.9	43536.4	19154.5	-39096.3
	11:29	-48:04.4	11:29	-63:54.0	43535.6	19153.0	-39096.2
	mean	11:08	-48:04.4	11:08	-63:53.9	43535.6	19153.6
1997 05/22*	10 13	-48:03 4	10 13	-63:54 0	43531.8	19151.3	-39092.8
	10:25	-48:03 5	10:25	-63:54.0	43533.6	19152.1	-39094.4
	10:44	-48:03.2	10:44	-63 54 0	43533.4	19152.1	-39094.2
	10:52	-48:03.6	10 52	-63 54.0	43532.8	19151.8	-39093.7
	mean	10:30	-48:03 4	10:30	-63.54.0	43532.9	19151.8
1997 05/23	12:02	-48:03 51	12:30	-63:53.58	43536.1	19158.0	-39094.2
	12:08	-48 03.51	12 35	-63:53 50	43536.8	19159.3	-39094.4
	12:12	-48:03.64	12 38	-63 53.54	43535.8	19158.4	-39093.8
	12:16	-48 03 61	12:41	-63 53.65	43536.3	19157.3	-39094.9
	mean	12:08	-48:03.57	12:35	-63 53 57	43536.1	19158.2
1997 06/12	11 12	-48.03 51	11 44	-63:53 76	43533 6	19154 9	-39093.0
	11 17	-48 03.44	11 49	-63.53 76	43535.3	19155 6	-39094 5
	11 20	-48:03 50	11 53	-63 53 70	43537 3	19157 2	-39096 0
	11:24	-48:03 41	11 57	-63 53 65	43541 6	19159 6	-39099 5
	mean	11:17	-48.03.47	11:50	-63 53 72	43537.1	19156.8
1997 07/12	08:12	-48 06 64					
	08 16	-48:06 02					
	08 20	-48 05 58					
	08:24	-48:05.78					
	mean	08.18	-48 06 00				
1997 07/14	10 48	-48:04.66	11 15	-63:52.67	43525 1	19163 5	-39079 4
	10:51	-48:04.41	11:19	-63:52.65	43527.4	19164 7	-39081 3
	10:55	-48:04.47	11 23	-63.52.56	43530 6	19167 2	-39083 6
	10:58	-48:04.74	11 26	-63 52 60	43529 4	19166 2	-39082 7
	mean	10 53	-48:04.57	11:20	-63 52 62	43527.8	19165 4

DI meter F1 type (\*GSI type)

DATE	TIME hh mm	DECLINATION (deg mm)	TIME hh mm	DIP ANGLE (deg mm)	TOTAL (nT)	HORIZONTAL (nT)	VERTICAL (nT)
1997 07/30	11:22	-48:04.43	11:49	-63:52.27	43525.0	19168.0	-39077.0
	11:26	-48:05.08	11:53	-63:52.27	43524.1	19167.6	-39076.1
	11:30	-48:05.14	11:57	-63:52.33	43523.8	19166.8	-39076.3
	11:34	-48:04.73	12:00	-63:52.30	43524.7	19167.6	-39076.8
	mean	11:28	-48:04.85	11:55	-63:52.29	43524.5	19167.5
1997 08/19	11:45	-48:07.28	12:09	-63:52.43	43516.4	19162.5	-39070.2
	11:49	-48:07.35	12:13	-63:52.45	43516.1	19162.1	-39070.0
	11:52	-48:07.31	12:16	-63:52.52	43518.2	19162.2	-39072.3
	11:56	-48:07.31	12:20	-63:52.51	43520.5	19163.3	-39074.3
	mean	11:50	-48:07.31	12:14	-63:52.48	43518.0	19162.5
1997 09/01	11:20	-48:07.28	11:46	-63:52.72	43530.6	19165.4	-39084.5
	11:24	-48:07.38	11:50	-63:52.80	43528.2	19163.4	-39082.8
	11:27	-48:07.33	11:53	-63:52.92	43523.7	19160.0	-39079.4
	11:31	-48:07.39	11:57	-63:53.03	43518.4	19156.5	-39075.3
	mean	11:26	-48:07.35	11:52	-63:52.87	43525.0	19161.3
1997 09/17	10:39	-48:07.19	11:05	-63:53.75	43520.0	19149.1	-39080.8
	10:42	-48:07.06	11:09	-63:53.71	43524.6	19151.5	-39084.7
	10:46	-48:07.04	11:13	-63:53.55	43526.4	19154.1	-39085.3
	10:49	-48:07.05	11:17	-63:53.45	43525.3	19154.7	-39083.9
	mean	10:44	-48:07.09	11:11	-63:53.61	43523.6	19152.3
1997 10/04	10:25	-48:09.12	10:47	-63:53.61	43501.1	19142.3	-39063.0
	10:29	-48:09.42	10:50	-63:53.65	43500.5	19141.5	-39062.7
	10:32	-48:09.72	10:53	-63:53.75	43499.4	19139.9	-39062.3
	10:35	-48:09.51	10:56	-63:53.76	43499.3	19139.8	-39062.2
	mean	10:30	-48:09.44	10:51	-63:53.69	43500.1	19140.9
1997 10/05	10:02	-48:08.99	10:22	-63:53.37	43503.4	19146.0	-39063.7
	10:05	-48:09.01	10:25	-63:53.33	43504.1	19146.8	-39064.1
	10:08	-48:09.04	10:28	-63:53.36	43504.2	19146.5	-39064.4
	10:10	-48:09.01	10:31	-63:53.39	43504.1	19146.1	-39064.5
	mean	10:06	-48:09.01	10:26	-63:53.36	43503.8	19146.3
1997 10/22	10:44	-48:08.78	11:04	-63:53.12	43503.7	19148.9	-39062.6
	10:47	-48:09.02	11:06	-63:53.17	43503.2	19148.2	-39062.5
	10:50	-48:08.90	11:09	-63:53.18	43503.2	19148.0	-39062.5
	10:53	-48:08.61	11:13	-63:53.17	43503.8	19148.5	-39063.0
	mean	10:49	-48:08.82	11:08	-63:53.16	43503.6	19148.4
1997 11/03	10:10	-48:11.19	10:29	-63:53.16	43492.3	19143.5	-39052.6
	10:13	-48:11.03	10:32	-63:53.09	43493.3	19144.7	-39053.1
	10:16	-48:10.77	10:34	-63:53.05	43496.3	19146.6	-39055.6
	10:18	-48:10.50	10:37	-63:52.94	43499.4	19149.1	-39057.8
	mean	10:14	-48:10.88	10:33	-63:53.06	43495.6	19146.0

DI meter · FT type (\*GSI type)

DATE	TIME hh:mm	DECLINATION (deg mm)	TIME hh:mm	DIP ANGLE (deg mm)	TOTAL (nT)	HORIZONTAL (nT)	VERTICAL (nT)
1997 11/21	10:48	-48:08.07	11:05	-63:53.74	43489.6	19135.7	-39053.4
	10:51	-48:07.47	11:08	-63:53.81	43488.1	19134.3	-39052.5
	10:54	-48:07.13	11:11	-63:53.96	43486.3	19131.8	-39051.6
	10:56	-48:07.15	11:13	-63:53.97	43485.6	19131.3	-39051.1
	mean	10:52	-48:07.46	11:09	-63:53.87	43487.5	19133.3
1997 12/01	07:05	-48:13.02	07:27	-63:52.17	43483.3	19150.8	-39039.0
	07:08	-48:13.37	07:30	-63:52.20	43484.3	19150.9	-39040.1
	07:12	-48:13.45	07:33	-63:52.24	43484.9	19150.7	-39040.8
	07:15	-48:13.10	07:36	-63:52.36	43484.7	19149.3	-39041.3
	mean	07:10	-48:13.24	07:32	-63:52.24	43484.2	19150.4
1997 12/01*	10:26	-48:10.5	10:26	-63:53.6	43487.5	19136.4	-39050.7
	10:32	-48:10.4	10:32	-63:53.8	43487.2	19134.0	-39051.6
	10:45	-48:09.4	10:45	-63:53.7	43490.3	19136.5	-39053.8
	10:51	-48:09.0	10:51	-63:54.0	43492.8	19134.2	-39057.7
	mean	10:38	-48:09.8	10:38	-63:53.8	43489.5	19135.3
1997 12/01	11:17	-48:08.46	11:37	-63:53.09	43506.1	19150.3	-39064.6
	11:20	-48:08.58	11:40	-63:53.02	43506.5	19151.3	-39064.5
	11:24	-48:08.45	11:43	-63:52.94	43508.1	19153.0	-39065.6
	11:26	-48:08.15	11:45	-63:52.88	43508.6	19153.8	-39065.7
	mean	11:22	-48:08.41	11:41	-63:52.98	43507.4	19152.1
1997 12/01*	12:13	-48:07.3	12:13	-63:52.7	43512.0	19157.4	-39067.7
	12:19	-48:07.5	12:19	-63:52.2	43516.9	19165.3	-39069.3
	12:27	-48:07.8	12:27	-63:51.8	43529.1	19175.2	-39078.1
	12:34	-48:07.8	12:34	-63:51.4	43526.0	19178.4	-39073.0
	mean	12:22	-48:07.6	12:22	-63:52.0	43521.0	19169.1
1997 12/01	13:30	-48:07.01	13:49	-63:51.79	43530.5	19175.9	-39079.2
	13:33	-48:06.83	13:52	-63:51.29	43540.0	19185.7	-39085.0
	13:36	-48:06.46	13:54	-63:51.25	43541.8	19187.0	-39086.4
	13:39	-48:06.08	13:57	-63:51.34	43539.6	19185.0	-39084.9
	mean	13:35	-48:06.60	13:53	-63:51.42	43536.6	19183.4
1997 12/01*	14:20	-48:03.8	14:20	-63:52.0	43538.4	19177.0	-39087.5
	14:28	-48:05.1	14:28	-63:52.4	43533.0	19170.1	-39084.9
	14:36	-48:05.5	14:36	-63:52.8	43520.6	19160.1	-39076.0
	14:43	-48:06.0	14:43	-63:52.6	43520.4	19162.2	-39074.7
	mean	14:31	-48:05.1	14:31	-63:52.4	43528.1	19167.3
1997 12/01	16:25	-48:06.46	16:44	-63:52.04	43514.1	19165.9	-39065.9
	16:28	-48:06.37	16:47	-63:51.96	43514.2	19166.8	-39065.6
	16:31	-48:06.60	16:50	-63:51.92	43513.2	19166.9	-39064.4
	16:34	-48:06.59	16:52	-63:51.95	43511.1	19165.5	-39062.7
	mean	16:29	-48:06.51	16:48	-63:51.96	43512.9	19166.3

DI meter : FT type (\*GSI type)

DATE	TIME hh mm	DECLINATION (deg min)	TIME hh mm	DIP ANGLE (deg min)	TOTAL (nT)	HORIZONTAL (nT)	VERTICAL (nT)
1997 12/01*	17:15	-48:06.8	17:15	-63:51.9	43515.8	19168.2	-39066.7
	17:23	-48:06.5	17:23	-63:51.8	43516.4	19169.6	-39066.8
	17:30	-48:06.5	17:30	-63:51.8	43514.1	19168.6	-39064.6
	17:37	-48:06.5	17:37	-63:51.6	43513.6	19170.6	-39063.0
	mean	17:26	-48:06.6	17:26	-63:51.8	43515.0	19169.2
1997 12/01	18:10	-48:06.60	18:30	-63:51.50	43519.1	19174.2	-39067.4
	18:14	-48:06.72	18:32	-63:51.47	43518.8	19174.3	-39067.0
	18:17	-48:06.89	18:35	-63:51.44	43519.2	19174.9	-39067.2
	18:19	-48:06.86	18:37	-63:51.37	43520.3	19176.2	-39067.7
	mean	18:15	-48:06.77	18:33	-63:51.45	43519.5	19174.9
1997 12/14	19:13	-48:06.24	19:33	-63:50.63	43513.4	19181.6	-39057.4
	19:16	-48:06.40	19:36	-63:50.59	43513.3	19182.0	-39057.1
	19:19	-48:06.48	19:39	-63:50.53	43514.7	19183.3	-39058.1
	19:22	-48:06.40	19:42	-63:50.36	43517.6	19186.5	-39059.7
	mean	19:18	-48:06.38	19:38	-63:50.53	43515.1	19183.3
1997 12/26	17:26	-48:07.13	17:45	-63:50.56	43498.7	19175.8	-39043.9
	17:29	-48:07.17	17:48	-63:50.48	43498.9	19176.8	-39043.6
	17:32	-48:07.13	17:51	-63:50.49	43499.8	19177.2	-39044.5
	17:34	-48:07.24	17:53	-63:50.41	43500.7	19178.4	-39044.9
	mean	17:30	-48:07.17	17:49	-63:50.49	43499.7	19177.1
1998 01/13	11:34	-48:06.47	11:57	-63:50.73	43487.0	19168.8	-39034.3
	11:37	-48:06.37	12:00	-63:50.58	43488.6	19171.2	-39034.9
	11:40	-48:06.36	12:03	-63:50.62	43489.2	19171.0	-39035.7
	11:43	-48:05.96	12:05	-63:50.66	43488.7	19170.3	-39035.4
	mean	11:38	-48:06.29	12:01	-63:50.65	43488.2	19170.3
1998 01/14	20:12	-48:07.52					
	20:16	-48:07.69					
	20:21	-48:08.05					
	20:25	-48:08.37					
	mean	20:18	-48:07.91				
1998 01/28	12:41	-48:07.56	13:14	-63:51.86	43490.2	19157.4	-39043.5
	12:46	-48:07.73	13:18	-63:51.83	43493.4	19159.0	-39046.2
	12:51	-48:07.94	13:23	-63:51.78	43494.5	19160.2	-39046.9
	12:56	-48:08.18	13:26	-63:51.83	43496.0	19160.2	-39048.5
	mean	12:49	-48:07.85	13:19	-63:51.82	43493.2	19159.2

DI meter : FT type (\*GSI type)

Table 2. *K*-indices at Syowa Station in February 1997–January 1998.

	FEBRUARY	MARCH	APRIL	MAY	JUNE	JULY	AUGUST	SEPTEMBER	OCTOBER	NOVEMBER	DECEMBER	JANUARY
1	3111 1201	5432 2344	3522 1013	5121 2457	4221 1133	3200 0011	3412 1124	3311 0103	4444 4542	2522 1225	1121 1123	1221 2211
2	2421 1355	3522 2323	4521 2133	4432 2215	3200 1115	4100 0022	3300 0012	3310 0011	3201 1101	4111 0110	3122 1121	2221 3312
3	5211 1123	1121 1334	5511 0023	4332 2244	5542 1233	4201 1102	4013 4464	4322 2266	1122 2322	1111 1235	3221 2114	1111 2111
4	2111 1123	4211 1022	6442 2116	4211 1143	4221 0123	2210 1112	3221 0013	5522 1234	4211 1102	2431 2233	3022 2223	1111 2222
5	3111 2332	0111 1344	6521 1236	5411 0014	3310 0003	0010 1000	2010 0020	3101 0221	1110 0022	1222 3332	2222 3333	1101 1221
6	2532 2214	5421 2200	4122 2304	3001 1004	5211 0225	0221 1002	3300 0001	1221 3134	1011 1122	2442 3445	3211 0101	4522 3444
7	2111 0125	1222 2235	5511 1225	3310 0003	5511 3243	1422 2235	1111 0002	0100 1100	3311 2423	5642 3434	1111 2112	6653 2110
8	4112 4433	4211 1113	3110 1134	3200 0013	0132 3345	3220 0003	1200 1114	1001 1422	2232 3224	2211 2212	1111 0000	1122 2334
9	3322 4475	1111 0111	4211 1225	3321 0001	5755 4234	5420 0454	2011 1233	3432 3345	3452 2244	3321 2135	0111 0211	2222 3311
10	4554 4455	1111 0122	3101 0136	2110 0014	3431 0122	1133 2112	2221 1033	5432 2456	4563 2446	4542 3313	1222 4345	4322 3322
11	5333 3345	2111 1112	5662 2235	5221 0000	3110 0002	2011 1102	4532 2210	4312 2114	5541 1100	2532 2112	4343 2232	4421 2222
12	5331 0001	4442 3134	5322 3111	0000 0000	4000 1101	1100 0000	3101 1025	5521 2343	1422 1103	3211 0100	2220 0101	2222 1221
13	3111 2312	5431 1232	2522 1223	0100 0001	1000 0003	0110 0000	4332 1254	5421 2234	4222 2121	1111 1112	0111 0101	1121 2111
14	4332 1122	4211 0123	3111 1100	1000 0233	1000 0000	0000 0001	4663 1124	5522 2333	0111 1100	2122 4355	1220 0111	2221 1111
15	0111 2311	5421 1123	0011 0000	5564 4435	4511 0012	2213 3344	3322 1002	5533 2323	0011 1202	3432 2325	1121 1301	1011 1113
16	1221 2245	5441 1223	0000 2357	3411 2326	2201 2123	3121 0000	5312 0000	4411 0122	2110 0013	5422 2124	1111 1223	2110 2453
17	4443 2134	3321 1144	5653 2354	6512 1135	0110 0000	0121 0033	3112 3341	2211 1355	1012 1125	5421 0235	2311 1114	0000 1343
18	3321 1112	4421 1112	6443 3144	2311 1005	0100 0000	4423 2214	2211 1233	6651 2444	4311 1122	3332 3223	3531 1123	3332 2111
19	3211 0001	1211 1001	5533 2134	3100 0000	3222 2125	4432 3132	3300 0001	2111 0132	2111 1102	2111 1112	3211 0111	1111 1121
20	2111 0122	1110 0010	1211 0013	3121 0000	3111 1022	3211 2000	1111 1024	3221 3123	4111 1023	2221 1111	1111 1223	2422 3445
21	3433 3304	0012 1113	1102 4445	0011 0022	0000 0001	1121 1112	4511 1024	2222 1466	4111 0102	1111 1113	4111 1122	4332 1110
22	5411 2433	5521 1210	6642 0033	0000 0002	0421 1232	0001 1120	5321 1123	5411 0000	4411 1122	4664 5446	1121 1112	2111 2124
23	5522 2111	0112 0111	3111 1045	0000 0000	2001 2223	1110 0003	4100 0003	1111 0114	1111 1235	6655 4255	3321 1124	2111 1103
24	0322 3114	1222 2136	7532 2124	0112 1235	1011 0001	2022 2234	4312 2113	3121 0112	3433 4225	4522 3312	3211 0220	1121 0224
25	4311 1123	4421 2346	3311 1135	4320 0001	2211 2124	3210 1121	4311 0000	1110 1110	5522 2336	3321 1212	2221 0101	3521 2431
26	5523 4322	3422 3355	2101 0023	0000 2235	3110 0001	1010 0003	0000 0000	0111 1123	6521 2354	3221 2122	2111 1011	1111 1110
27	5521 2156	4111 1134	1000 0014	5753 2235	2013 4354	3111 1103	0021 0000	4122 2444	6652 1254	2221 1110	1101 1000	3323 1221
28	5653 3455	3211 1575	2101 0011	4221 1001	4521 1124	3110 1000	4743 1245	5552 2213	6322 2345	2221 1112	1111 0111	1111 0211
29		5622 2357	0000 0123	0100 0013	5522 2123	1210 0011	2332 2444	4321 2113	5332 1134	1111 1011	3120 1013	3211 2115
30		3532 2235	5522 0055	3200 1025	5100 0013	5400 0005	3532 2233	3421 1134	4111 3133	2222 2112	4653 4441	5553 3343
31		3311 1233		4111 1324		6643 3224	1111 1000		3211 1111		2122 2101	3331 1455



Table 3. Observation periods of a 35 mm film-type all-sky camera at Syowa Station in 1997.

Date	Hours (Universal Time)									K-Index	
	h	m	s	h	m	s	h	m	s		
FEB. 27	20	00	00	-23	27	00				5521	2156
28	20	10	00	-22	00	00				5653	3455
MAR. 5	19	00	00	-23	56	00				0111	1344
6							19	00	00	5421	2200
7	-00	05	00							1222	2235
8							22	45	00	4211	1113
9	-01	00	00				19	40	00	1111	0111
10	-00	06	00				19	05	00	1111	0122
11	-00	05	00				19	10	00	2111	1112
12	-00	05	00	21	13	00	-23	00	00	4442	3134
16							21	27	00	5441	1223
17	-00	30	00							3321	1144
18							18	30	00	4421	1112
19	-00	40	00							1211	1001
20							21	00	00	1110	0010
21	-01	01	00							0012	1113
23							19	18	00	0112	0111
24	-00	10	00	19	00	00	-23	40	00	1222	2136
25				17	32	00	-23	55	00	4421	2346
26							18	00	00	3422	3355
27	-01	43	00							4111	1134
28							16	50	00	3211	1575
29	-00	05	00				18	13	00	5622	2357
30	-01	11	00				20	00	00	3532	2235
31	-01	18	00							3311	1233
APR. 1							18	21	00	3522	1013
2	-00	14	00							4521	2133
3							17	30	00	5511	0023
4	-02	00	00				18	00	00	6442	2116
5	-02	05	00							6521	1236
9							16	30	00	4211	1225
10	-00	53	00				18	05	00	3101	0136
11	-01	35	00				19	51	00	5662	2235
12	-00	03	00							5322	3111

Date	Hours (Universal Time)									K-Index	
	h	m	s	h	m	s	h	m	s		
APR. 13							17	00	00	2522	1223
14	-03	00	00				16	44	00	3111	1100
15	-02	25	00							0011	0000
18							18	10	00	6443	3144
19	-02	50	00							5533	2134
MAY 3							17	50	00	4332	2244
4	-00	33	00				17	56	00	4211	1143
5	-00	56	00				16	40	00	5411	0014
6	-03	40	00							3001	1004
10							18	57	00	2110	0014
11	-03	40	00							5221	0000
12							21	25	00	0000	0000
13	-03	45	00				16	05	00	0100	0001
14	-04	00	00				20	50	00	1000	0233
15	-04	00	00				15	12	00	5564	4435
16	-03	35	00							3411	2326
25							17	12	00	4320	0001
26	-03	21	00				14	30	00	0000	2235
27	-04	00	00				16	36	00	5753	2235
28	-04	46	00				16	43	00	4221	1001
29	-04	00	00				21	37	00	0100	0013
30	-04	35	00				14	30	00	3200	1025
31	-03	51	00				15	06	00	4111	1324
JUN. 1	-04	19	00							4221	1133
2							21	55	00	3200	1115
3	-04	42	00				14	52	00	5542	1233
4	-04	36	00							4221	0123
6							16	40	00	5211	0225
7	-04	40	00				14	16	00	5511	3243
9							14	10	00	5755	4234
10	-04	54	00							3431	0122
11							23	21	00	3110	0002
12	-05	05	00							4000	1101
13	02	38	00	-04	33	00				1000	0003
14							23	32	00	1000	0000
15	-03	45	00							4511	0012
24							23	20	00	1011	0001
25	-05	04	00							2211	2124

Date	Hours (Universal Time)									K-Index	
	h	m	s	h	m	s	h	m	s		
JUN. 26							21	43	00	3110	0001
27	-04	42	00				16	40	00	2013	4354
28	-05	28	00				14	40	00	4521	1124
29	-05	10	00				23	12	00	5522	2123
30	-04	53	00				15	00	00	5100	0013
JUL. 1	-04	29	00				23	45	00	3200	0011
2	-04	39	00				14	37	00	4100	0022
3	-04	37	00				15	20	00	4201	1102
4	-04	48	00							2210	1112
5							21	48	00	0010	1000
6	-03	20	00							0221	1002
7							17	30	00	1422	2235
8	-04	16	00							3220	0003
14	01	33	00	-04	30	00				0000	0001
15							15	00	00	2213	3344
16	-03	30	00				20	20	00	3121	0000
17	-04	25	00				20	35	00	0121	0033
18	-04	43	00				15	00	00	4423	2214
19	-03	02	00				15	00	00	4432	3132
20	-04	33	00							3211	2000
21							21	32	00	1121	1112
22	-04	19	00							0001	1120
23							18	30	00	1110	0003
24	-04	30	00				15	05	00	2022	2234
25	-04	15	00				19	04	00	3210	1121
26	-04	10	00				21	26	00	1010	0003
27	-04	10	00				20	03	00	3111	1103
28	-04	08	00				20	48	00	3110	1000
29	-04	06	00				19	42	00	1210	0011
30	-04	19	00							5400	0005
31							16	56	00	6643	3224
AUG. 1	-04	04	00				17	54	00	3412	1124
2	-03	57	00				18	09	00	3300	0012
3	-04	10	00							4013	4464

Date	Hours (Universal Time)									K-Index	
	h	m	s	h	m	s	h	m	s		
AUG. 7							21	23	00	1111	0002
8	-03	36	00				21	24	00	1200	1114
9	-03	02	00				15	14	00	2011	1233
10	-02	52	00				17	35	00	2221	1033
11	-03	42	00							4532	2210
21							18	10	00	4511	1024
22	-02	50	00				18	06	00	5321	1123
23	-02	47	00				19	54	00	4100	0003
24	-02	40	00							4312	2113
26							17	47	00	0000	0000
27	-02	04	00							0021	0000
28							17	53	00	4743	1245
29	-02	24	00				17	07	00	2332	2444
30	-02	13	00				17	07	00	3532	2233
31	-02	31	00				19	51	00	1111	1000
SEP. 1	-02	35	00				20	52	00	3311	0103
2	-02	10	00				18	04	00	3310	0011
3	-02	08	00				17	48	00	4322	2266
4	-01	54	00				18	13	00	5522	1234
5	-01	13	00				18	50	00	3101	0221
6	-01	31	00				19	03	00	1221	3134
7	-01	30	00				22	32	00	0100	1100
8	-01	31	00				17	43	00	1001	1422
9	-01	30	00				17	25	00	3432	3345
10	-01	35	00				17	25	00	5432	2456
11	-01	42	00							4312	2114
18							17	55	00	6651	2444
19	-00	53	00				18	22	00	2111	0132
20	-00	42	00							3221	3123
21				17	47	00	-20	05	00	2222	1466
23							18	03	00	1111	0114
24	-00	27	00				20	08	00	3121	0112
25	-00	07	00							1110	1110
26							19	04	00	0111	1123
27	-00	35	00							4122	2444
28				19	34	00	-23	37	00	5552	2213
OCT. 5				20	30	00	-22	47	00	1110	0022

## Appendix

### Summary plots of the Upper Atmosphere Physics Monitoring data in 1997

- Plotted data from top:

H : northward component of the magnetic variation  
D : eastward component of the magnetic variation\*  
Z : downward component of the magnetic variation

\*Note that eastward is positive in these data, though westward is positive in the plots of past years.

- Plotting vertical scale:

H, D, Z : 100 nT/div

SYOWA magnetogram (100 nT/div)

01 Jan.1997 (DAY:001)

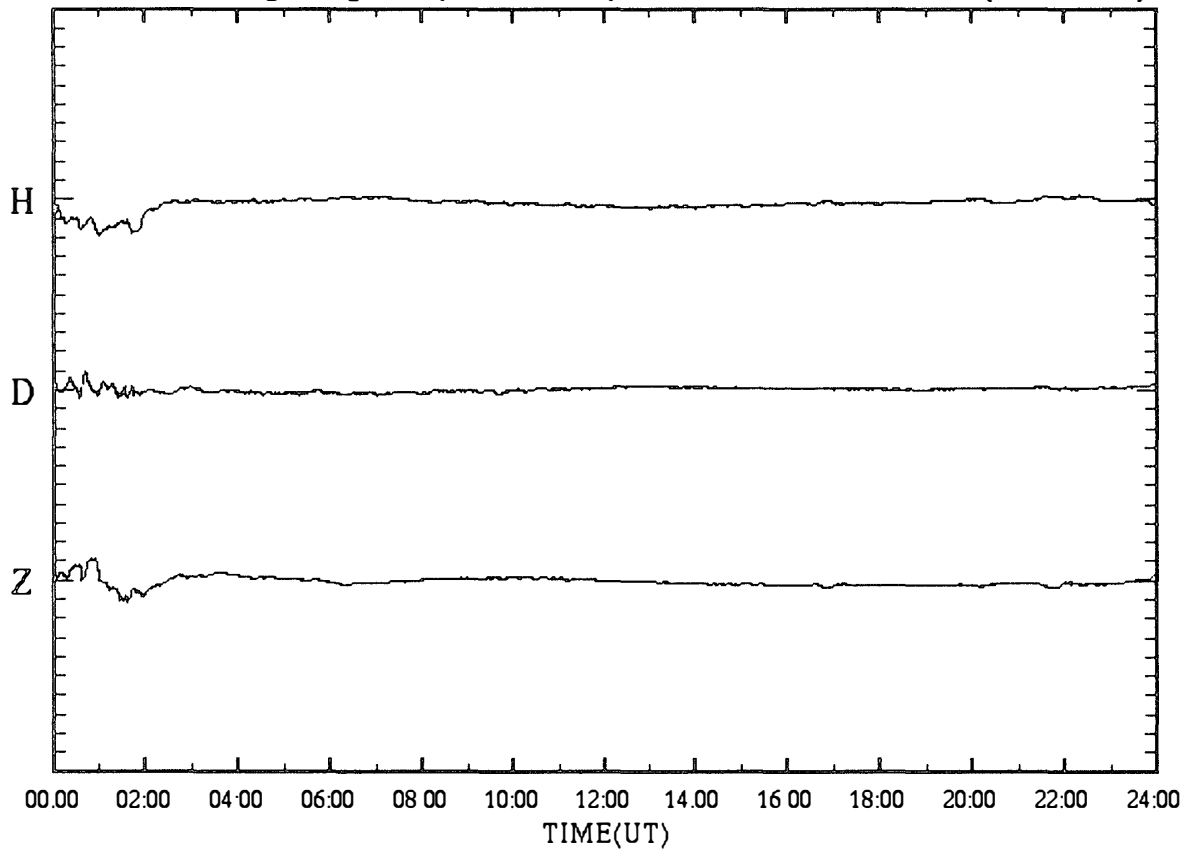

SYOWA magnetogram (100 nT/div)

02 Jan.1997 (DAY:002)

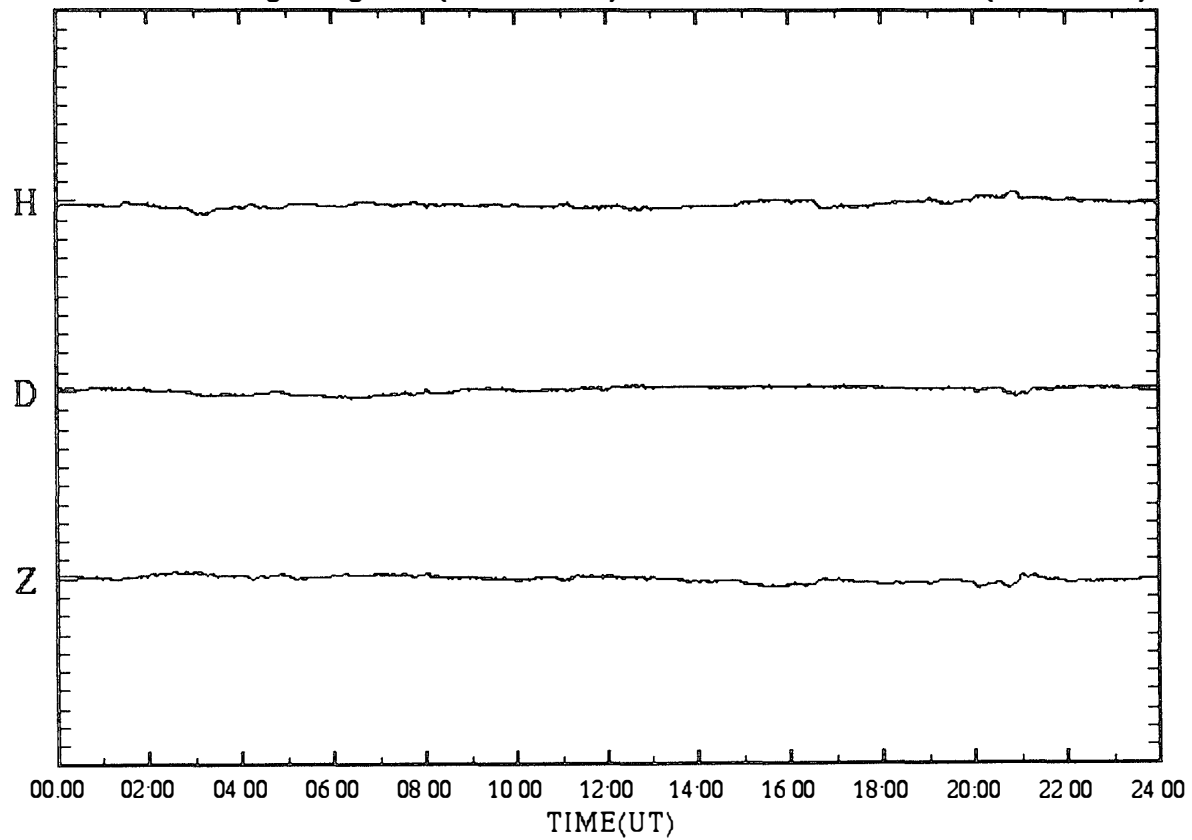

SYOWA magnetogram (100 nT/div)

03 Jan.1997 (DAY:003)

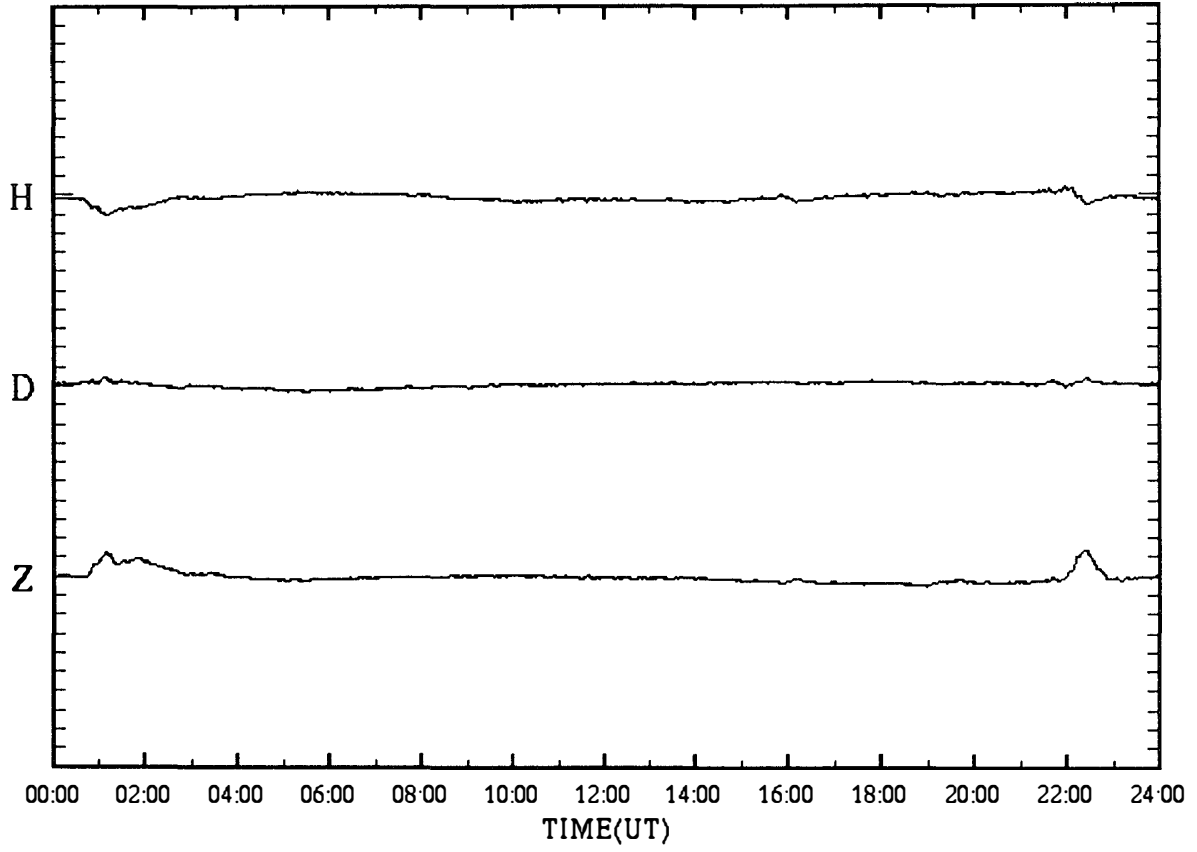

SYOWA magnetogram (100 nT/div)

04 Jan.1997 (DAY:004)

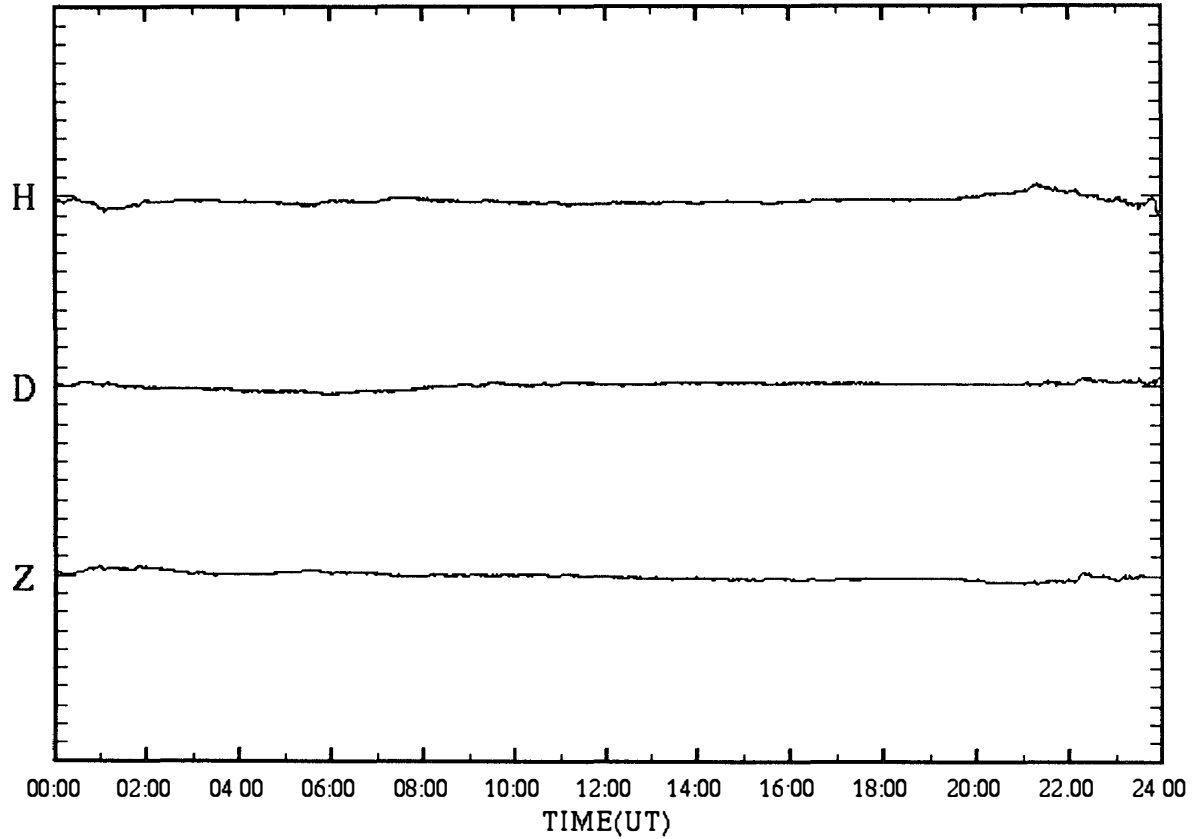

SYOWA magnetogram (100 nT/div)

05 Jan.1997 (DAY:005)

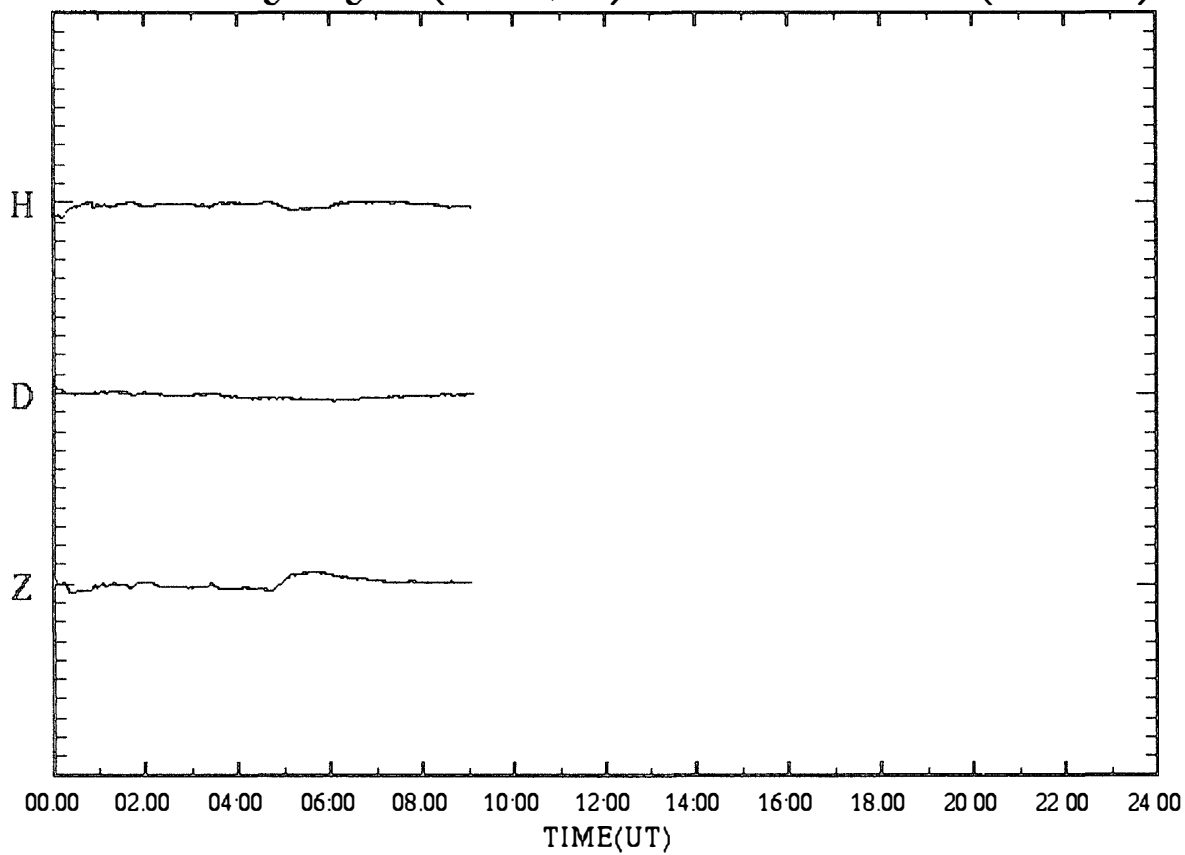

SYOWA magnetogram (100 nT/div)

06 Jan.1997 (DAY:006)

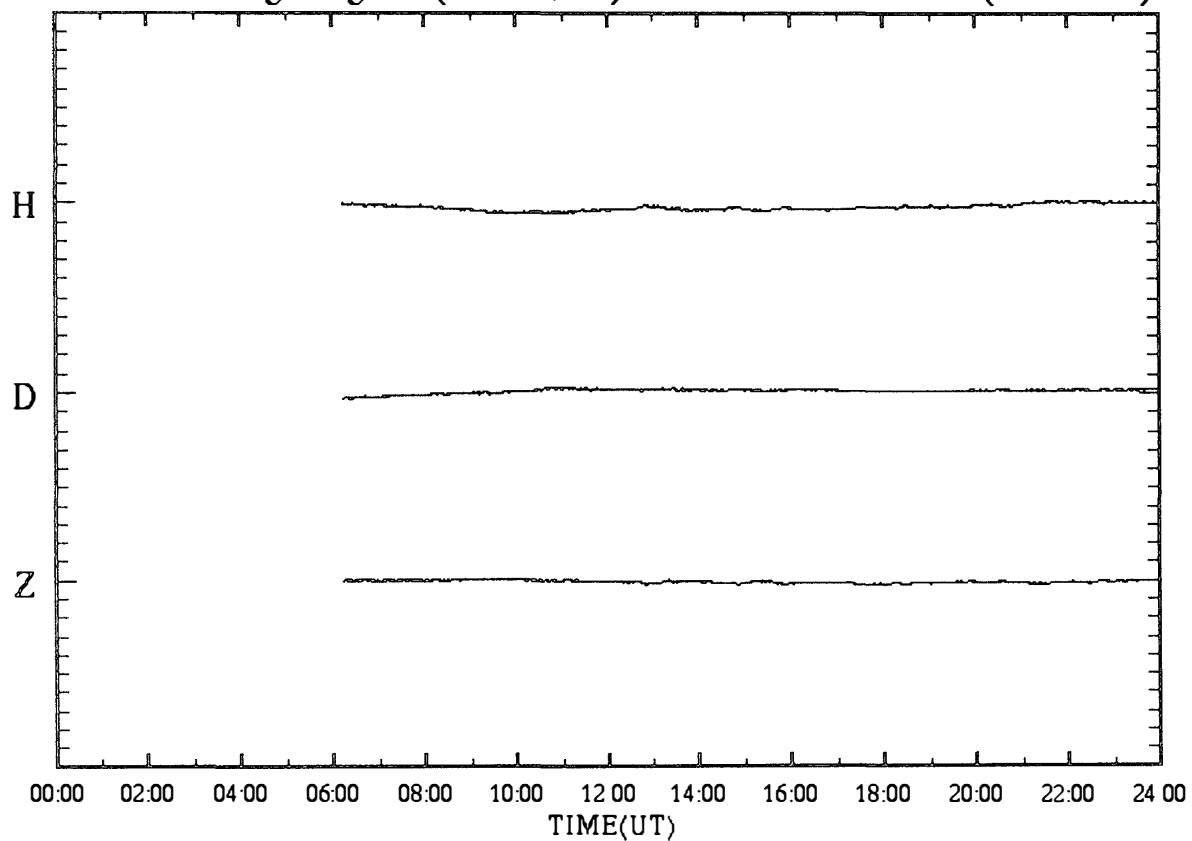



SYOWA magnetogram (100 nT/div)

07 Jan.1997 (DAY:007)

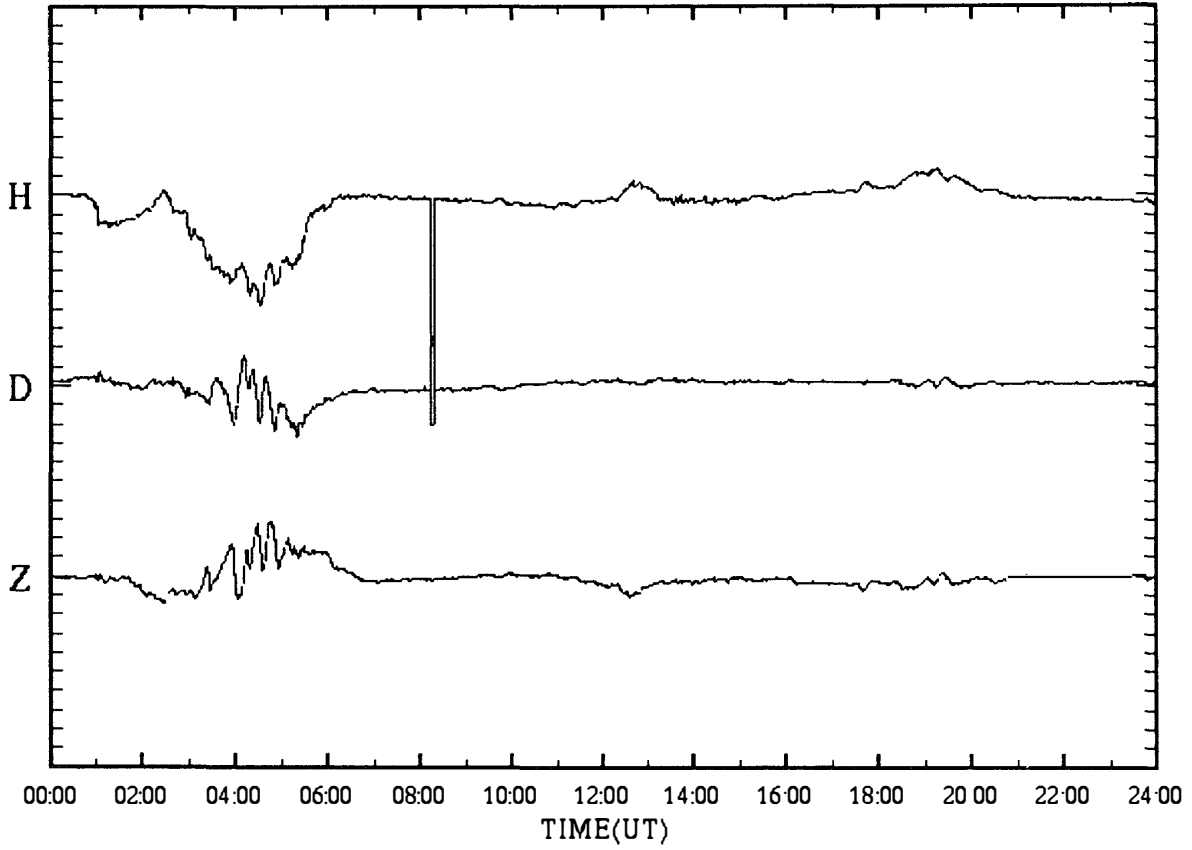

SYOWA magnetogram (100 nT/div)

08 Jan.1997 (DAY:008)

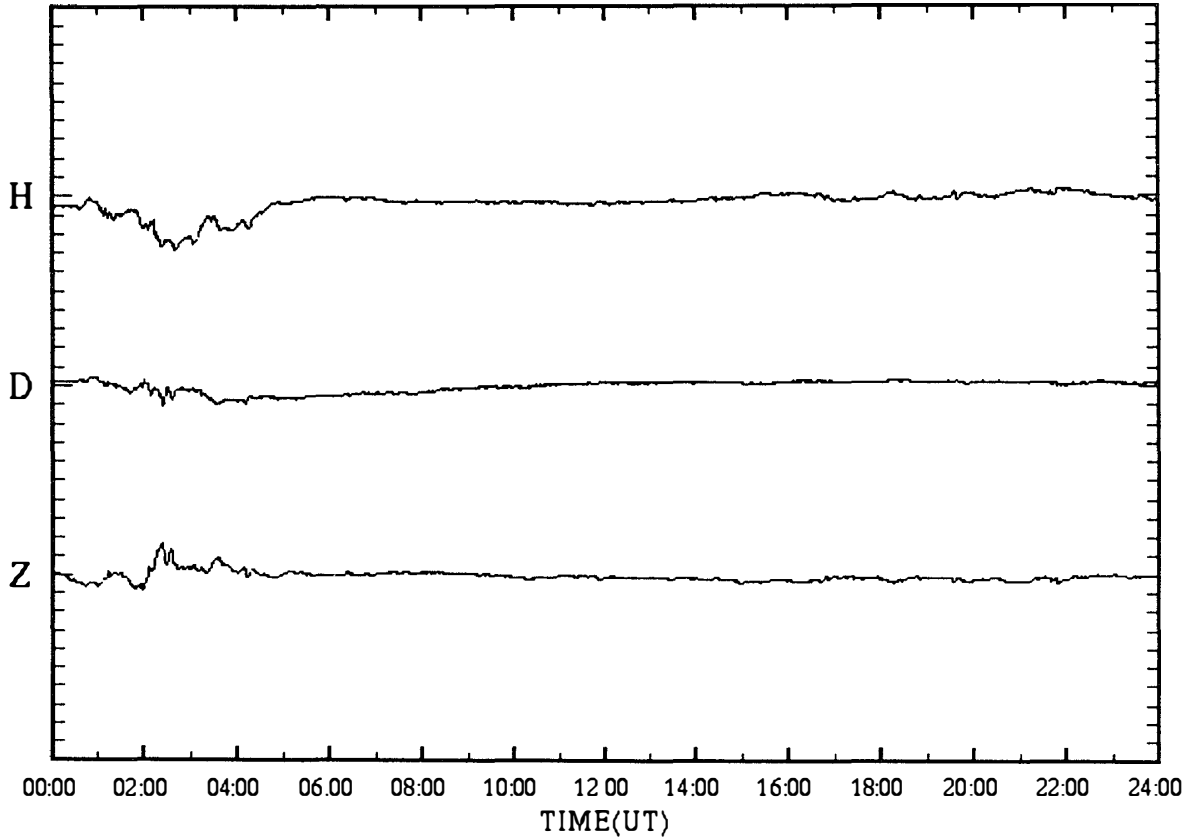

SYOWA magnetogram (100 nT/div)

09 Jan.1997 (DAY:009)

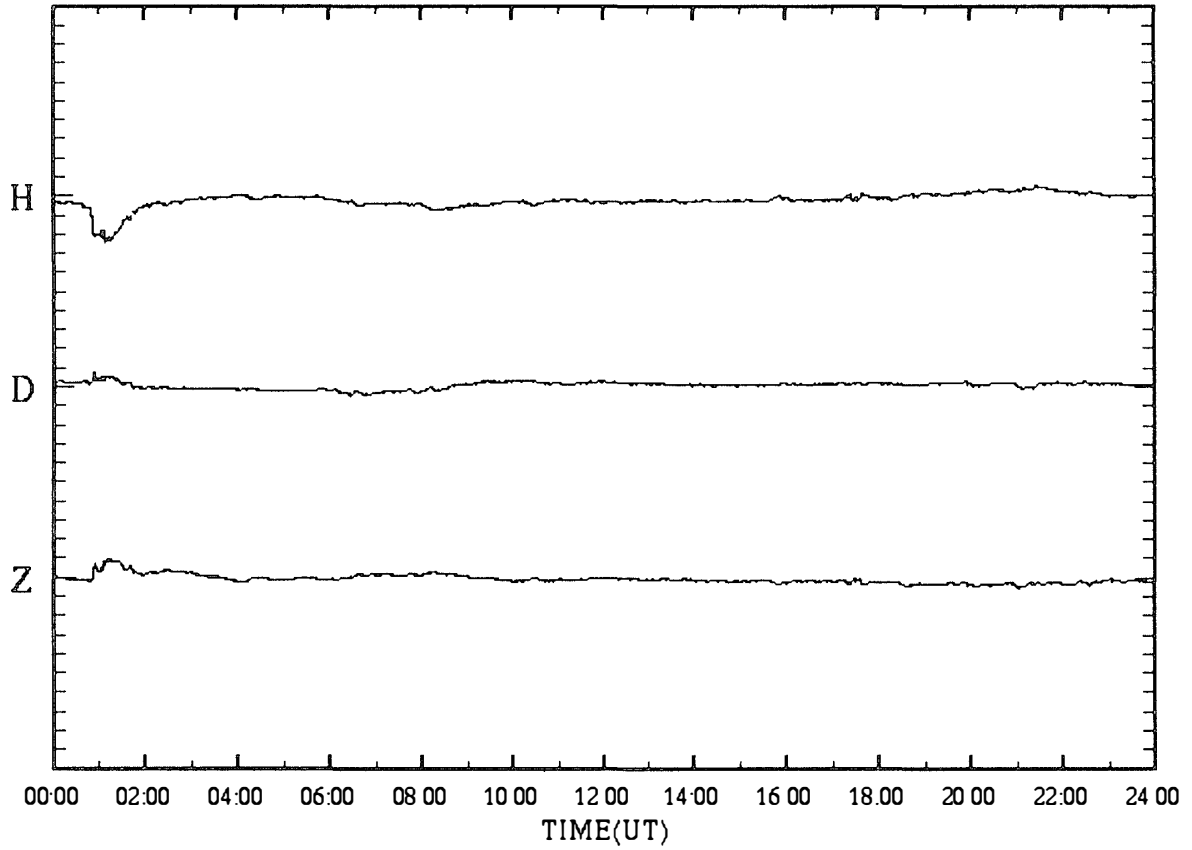

SYOWA magnetogram (100 nT/div)

10 Jan.1997 (DAY:010)

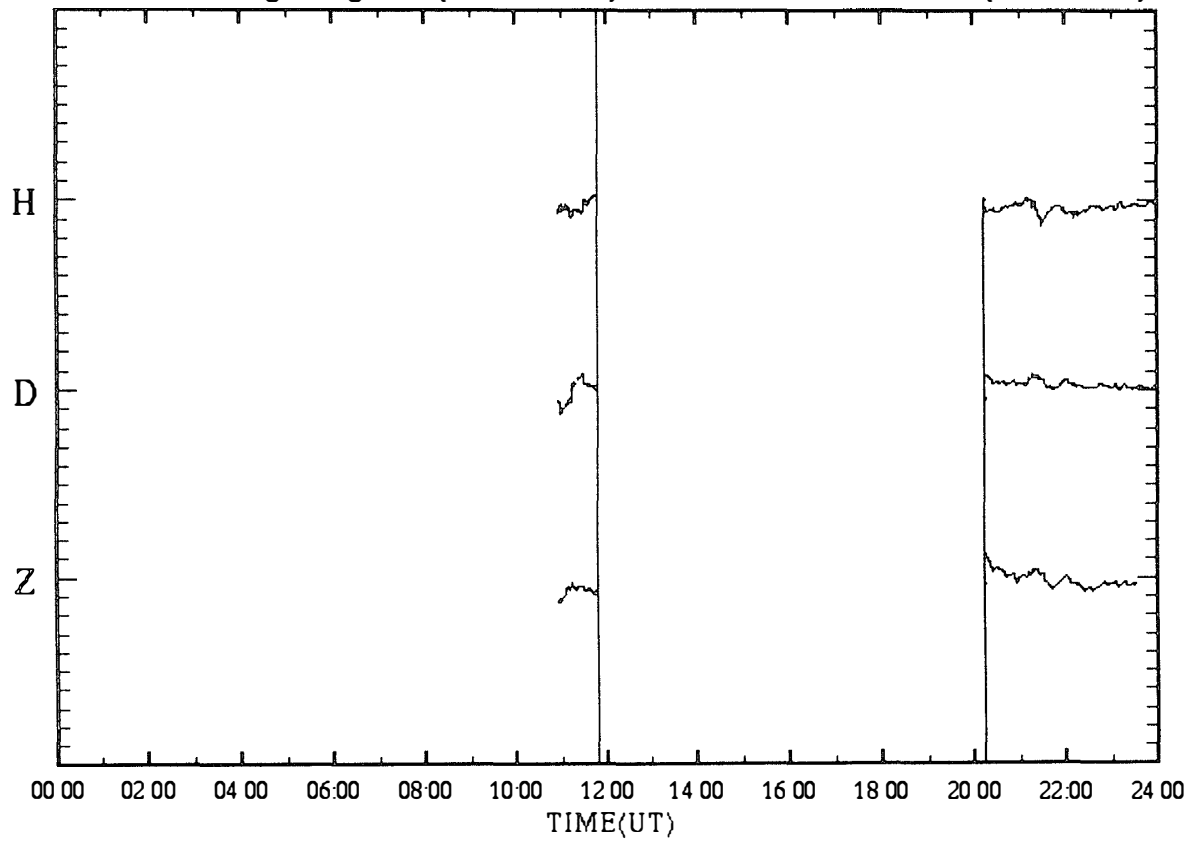

SYOWA magnetogram (100 nT/div)

11 Jan.1997 (DAY:011)

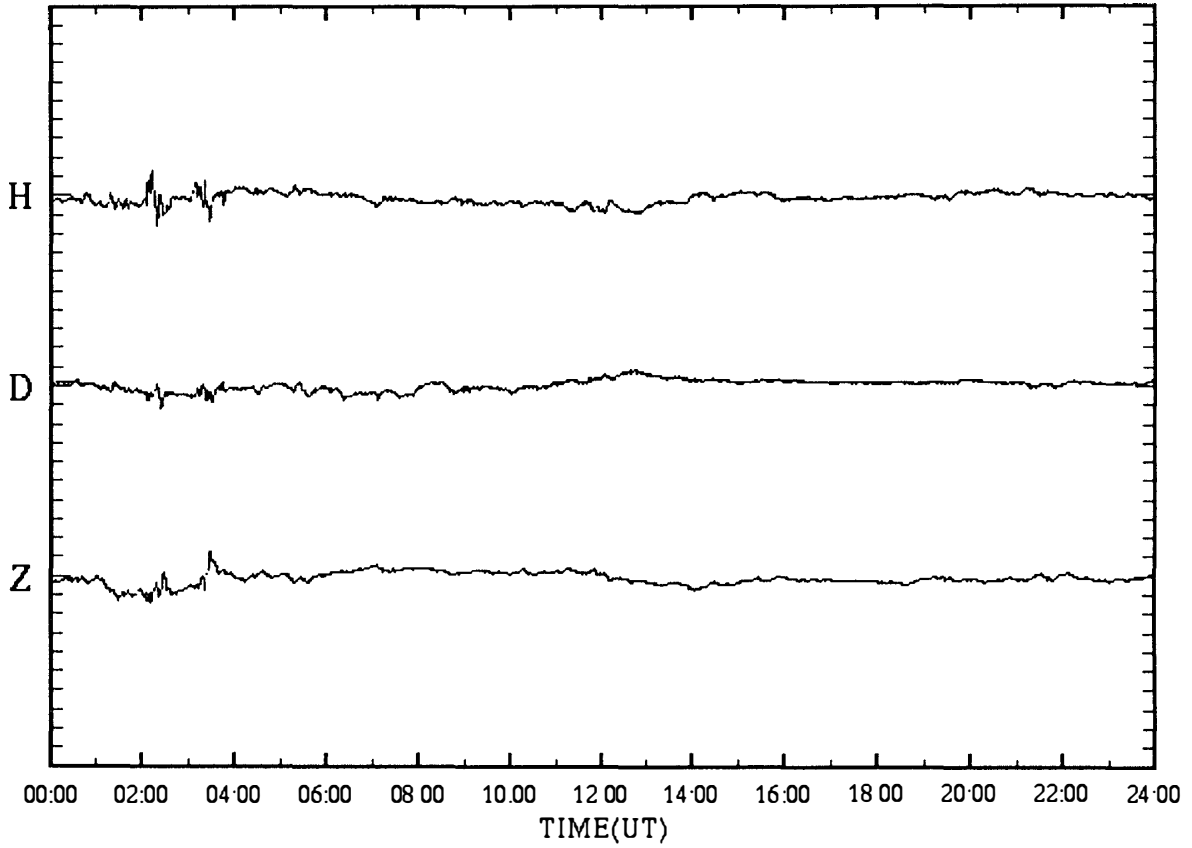

SYOWA magnetogram (100 nT/div)

12 Jan.1997 (DAY:012)

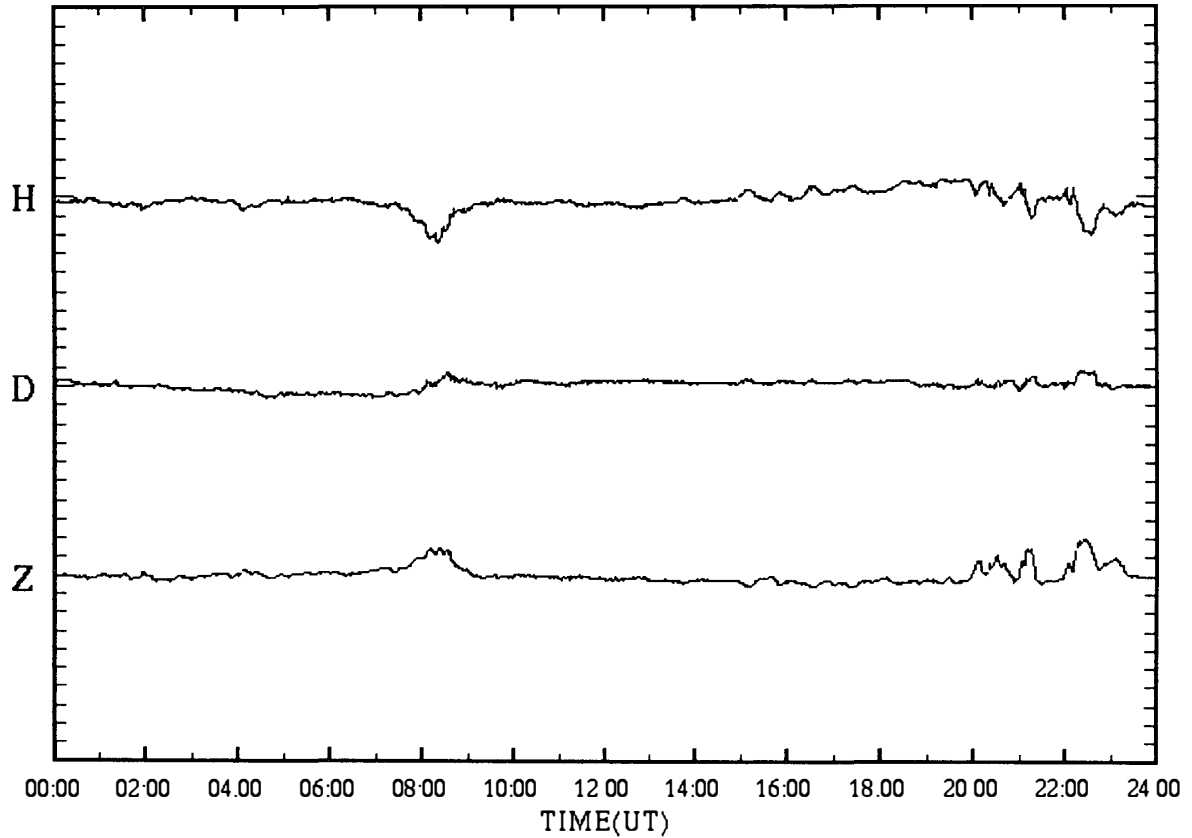

SYOWA magnetogram (100 nT/div)

13 Jan.1997 (DAY:013)

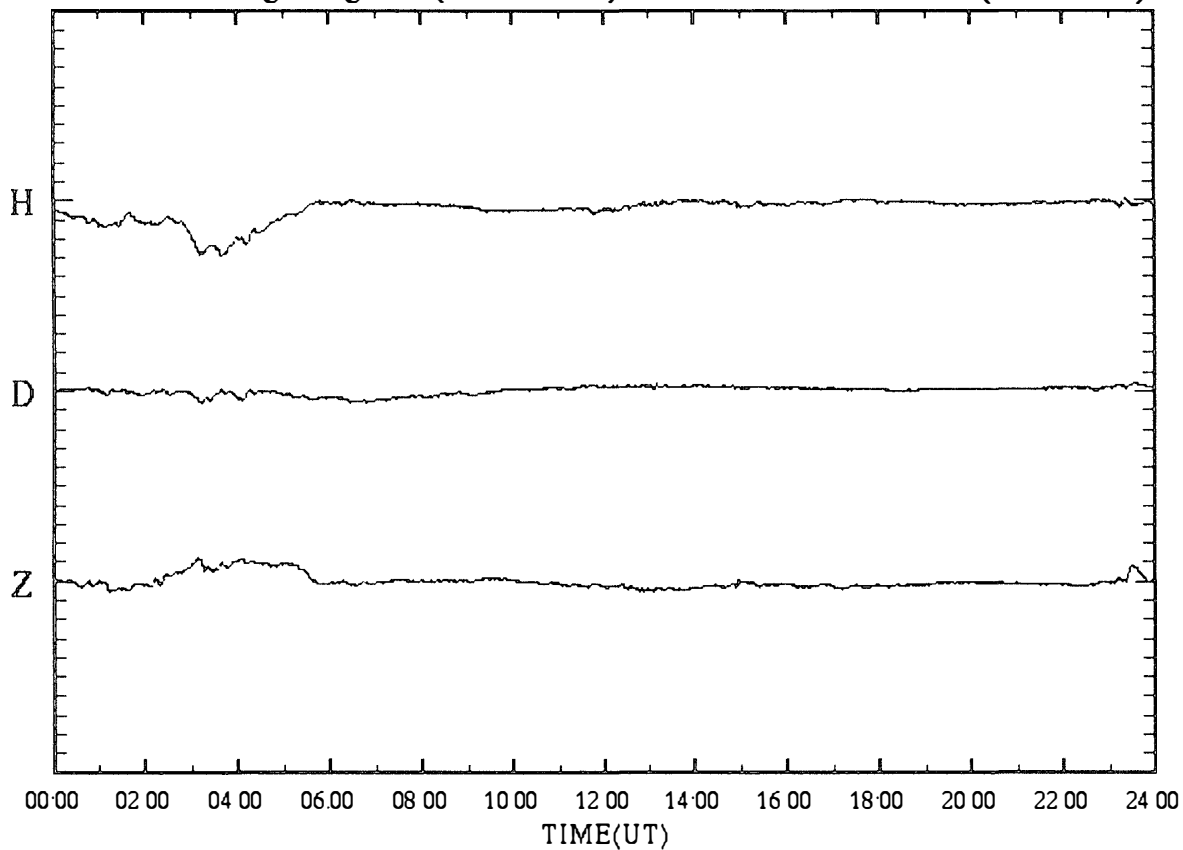

SYOWA magnetogram (100 nT/div)

14 Jan.1997 (DAY:014)

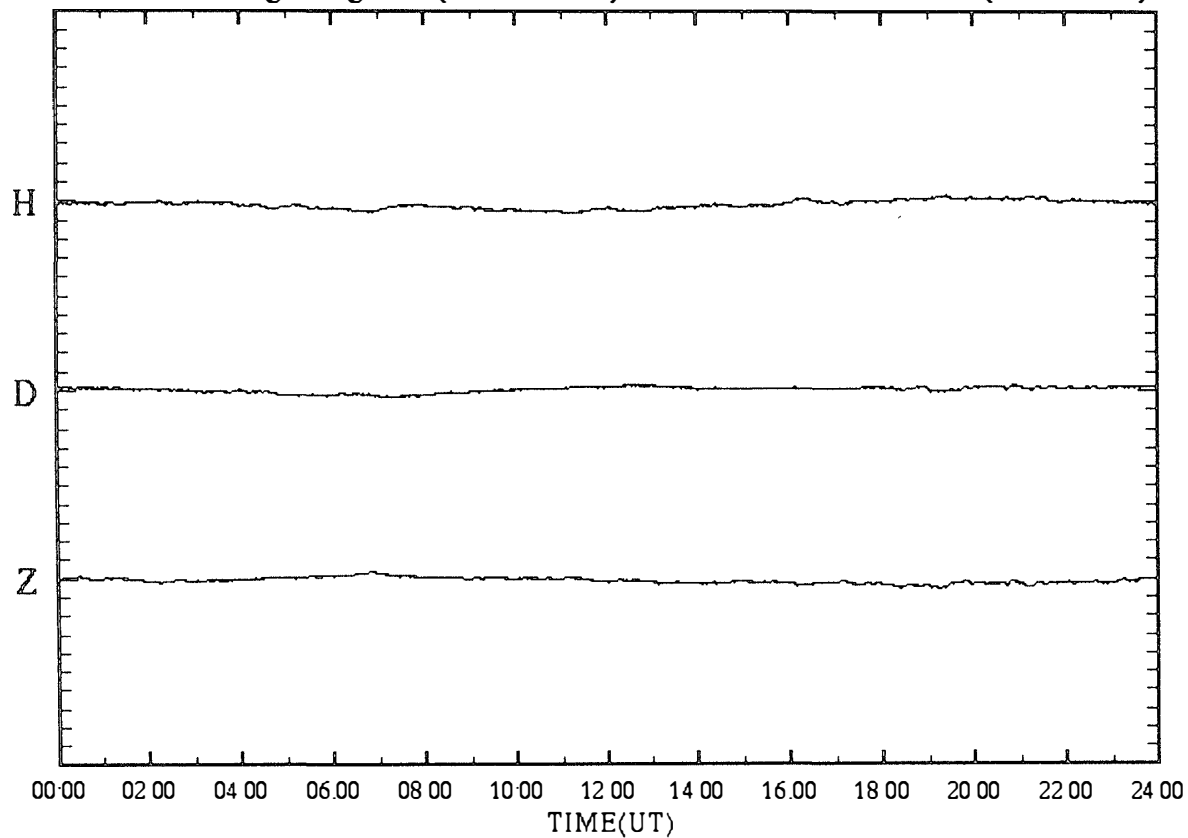

SYOWA magnetogram (100 nT/div)

15 Jan.1997 (DAY:015)

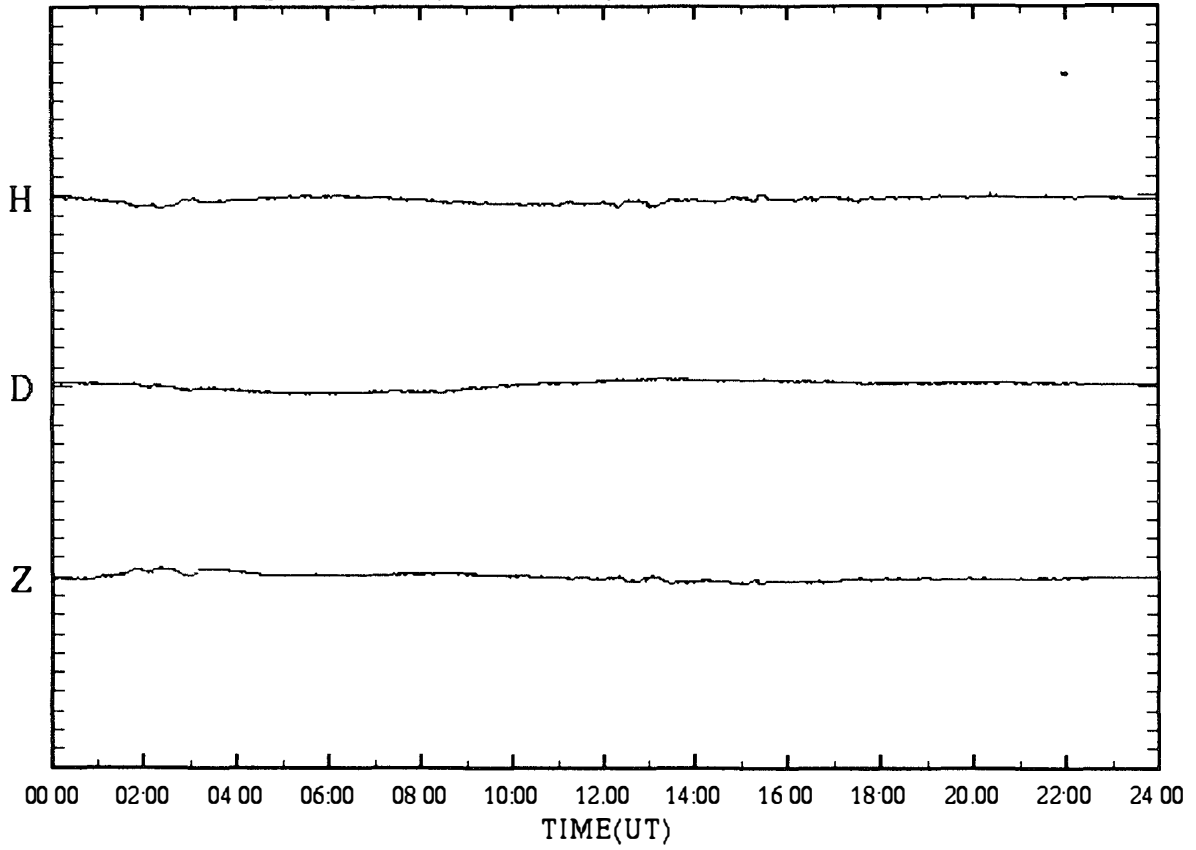

SYOWA magnetogram (100 nT/div)

16 Jan.1997 (DAY:016)

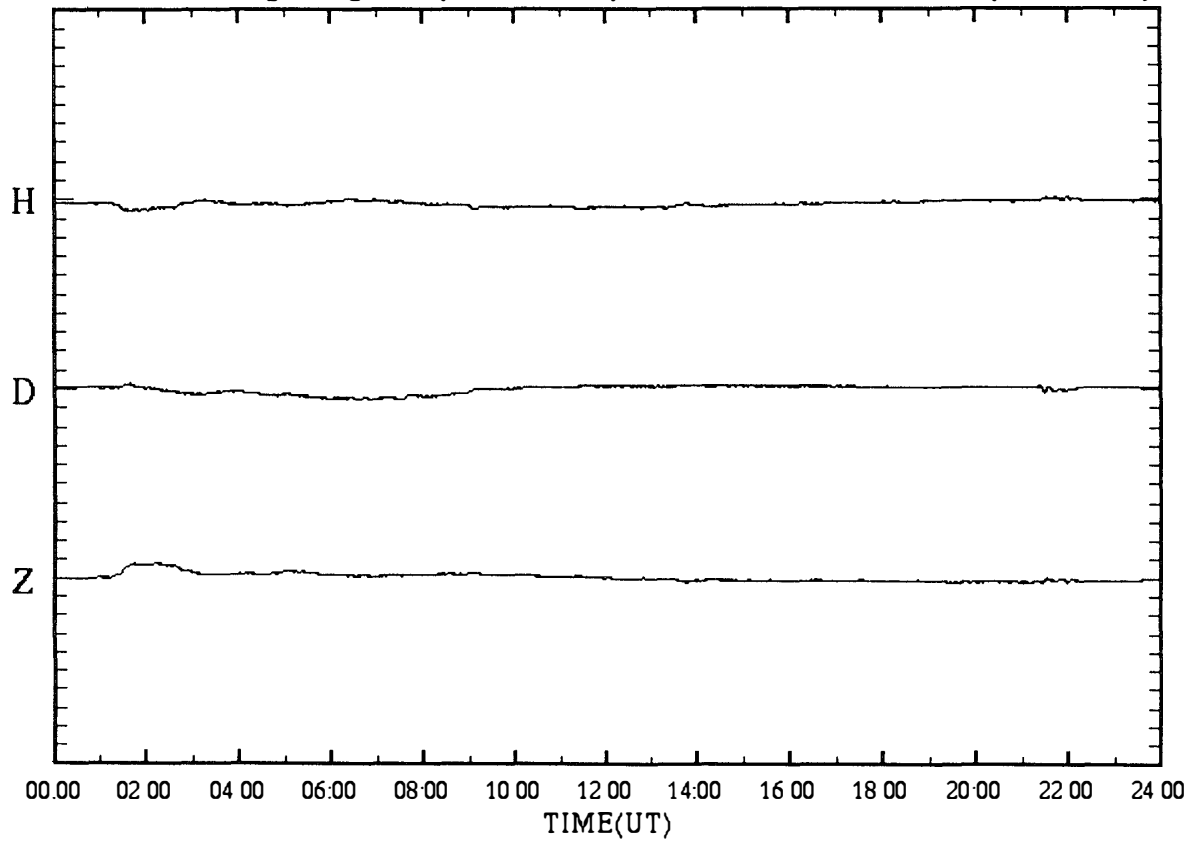

SYOWA magnetogram (100 nT/div)

17 Jan.1997 (DAY:017)

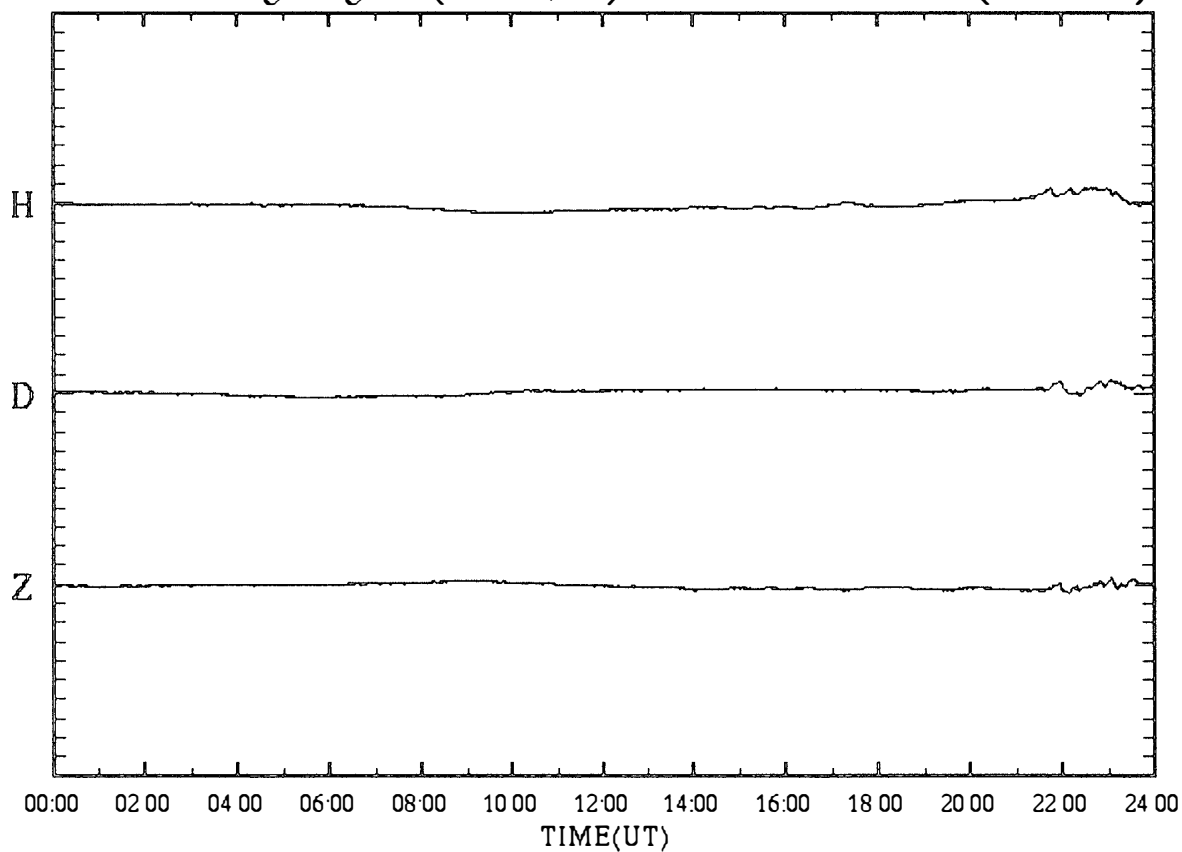

SYOWA magnetogram (100 nT/div)

18 Jan.1997 (DAY:018)

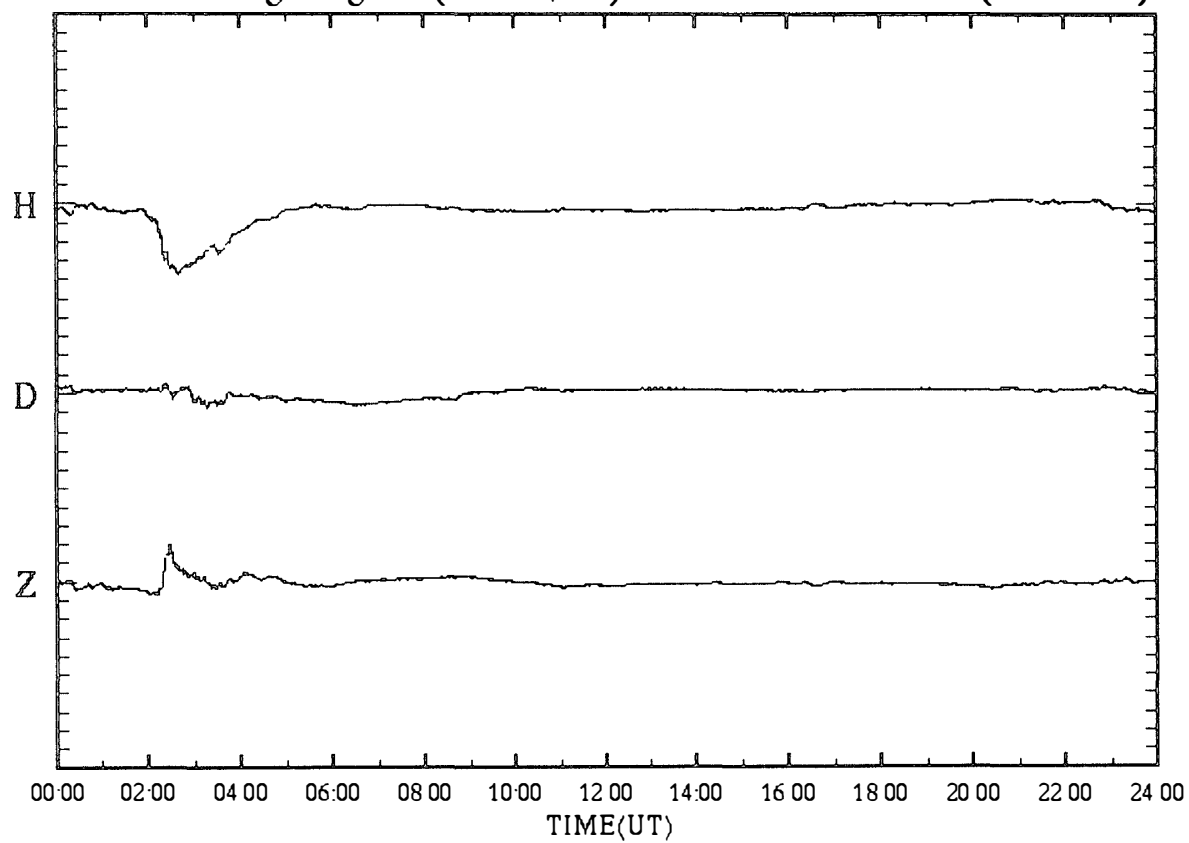

SYOWA magnetogram (100 nT/div)

19 Jan.1997 (DAY:019)

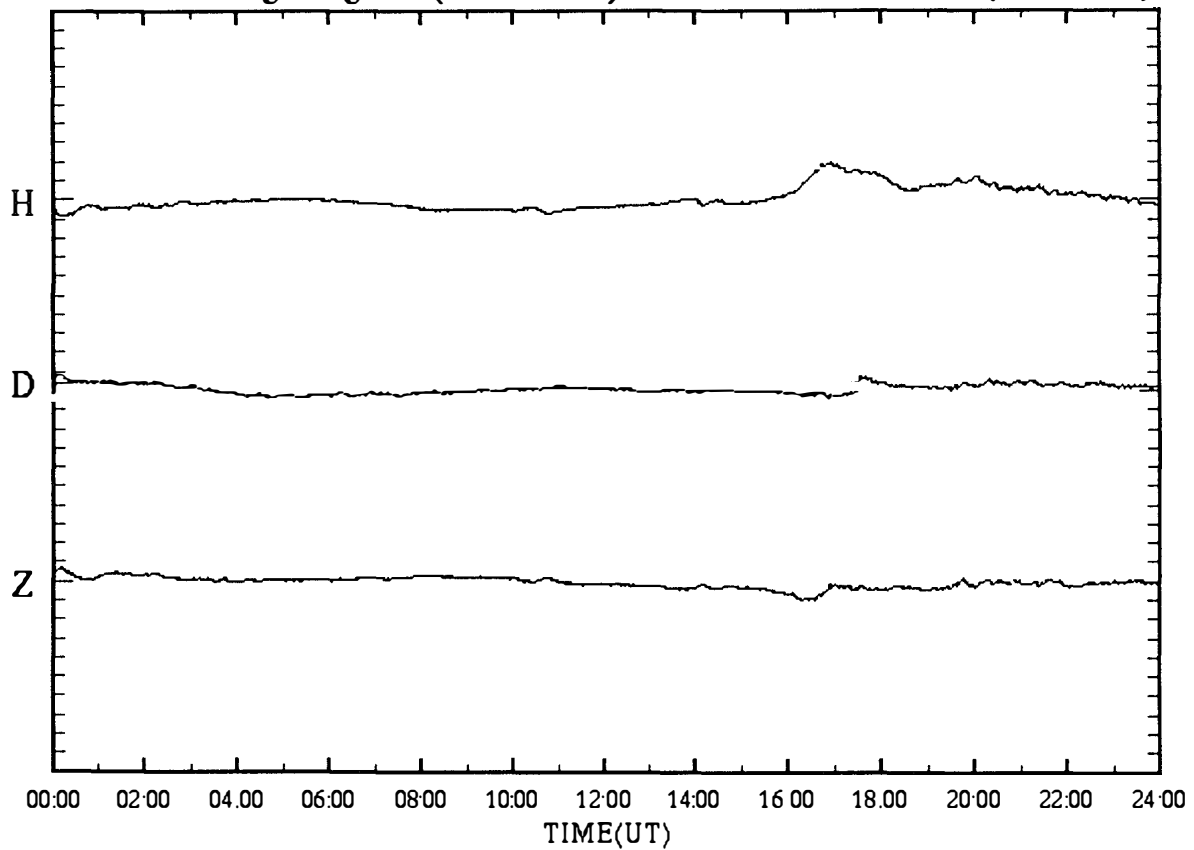

SYOWA magnetogram (100 nT/div)

20 Jan.1997 (DAY:020)

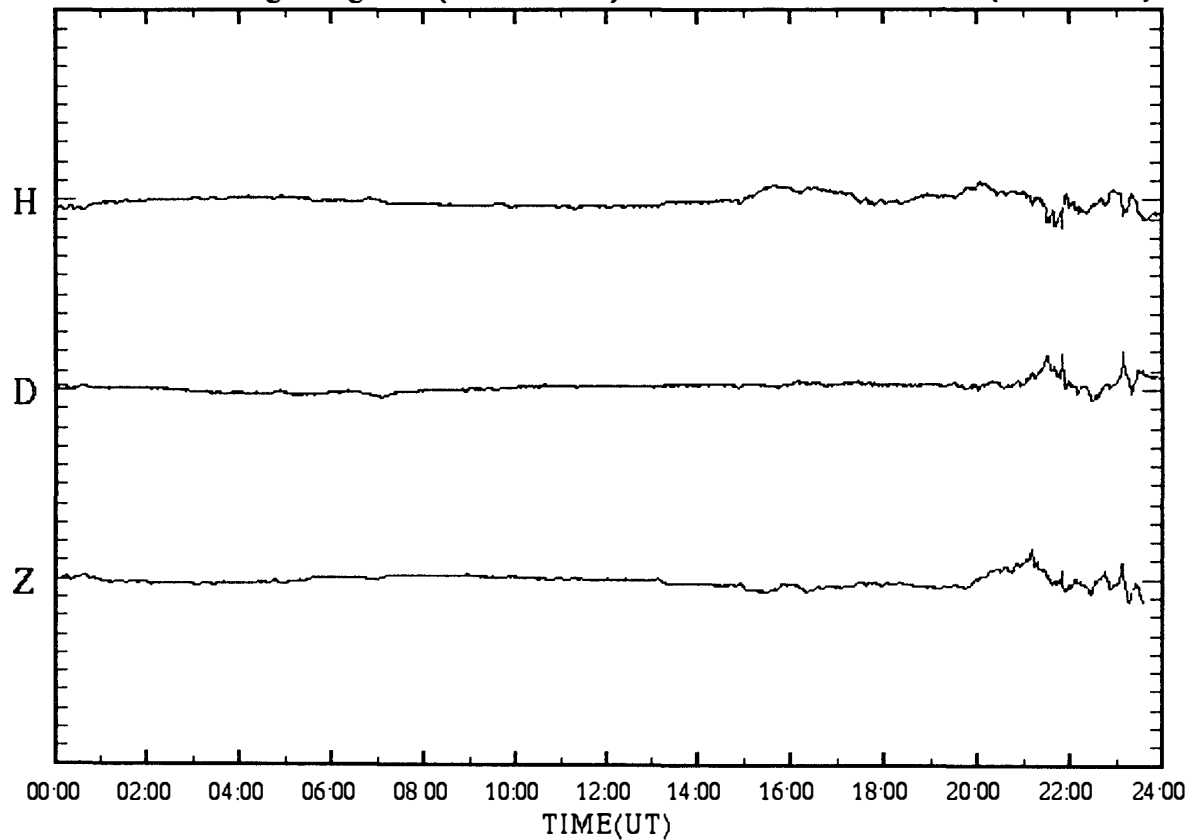

SYOWA magnetogram (100 nT/div)

21 Jan.1997 (DAY:021)

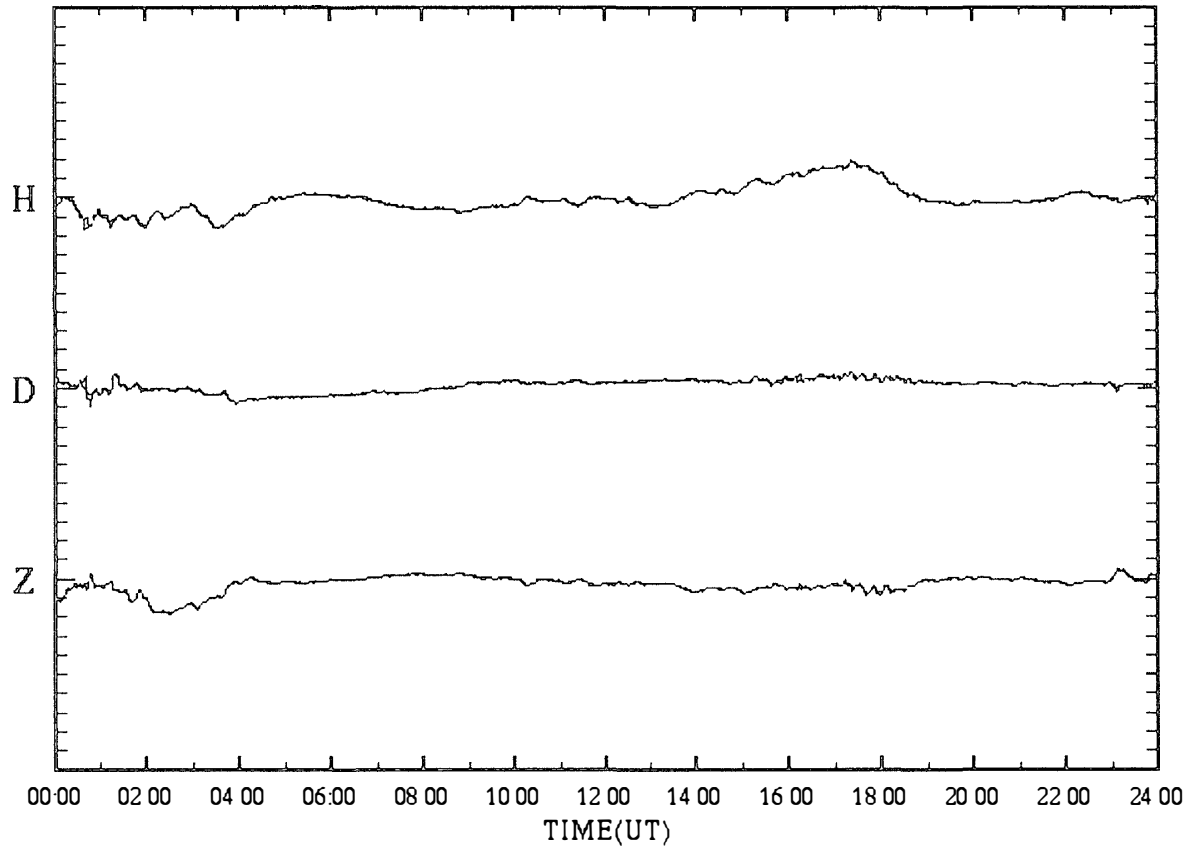

SYOWA magnetogram (100 nT/div)

22 Jan.1997 (DAY:022)

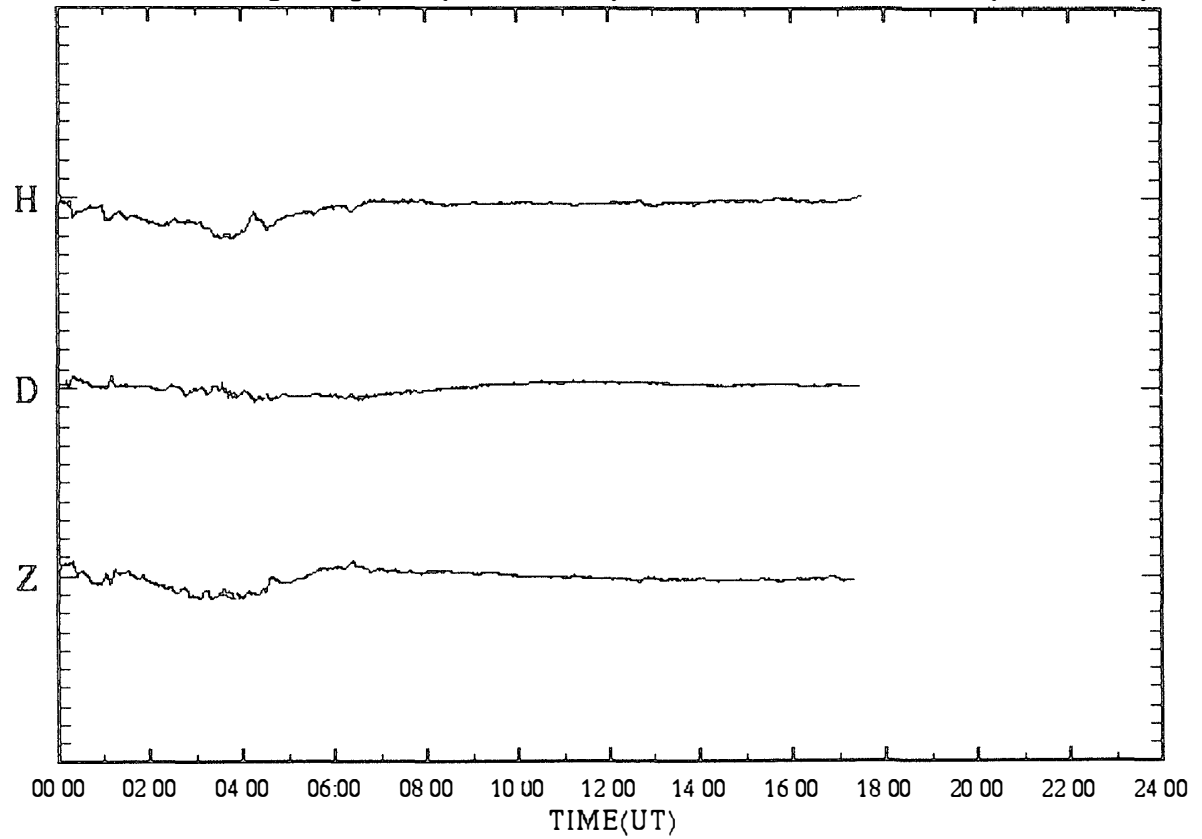



SYOWA magnetogram (100 nT/div)

23 Jan.1997 (DAY:023)

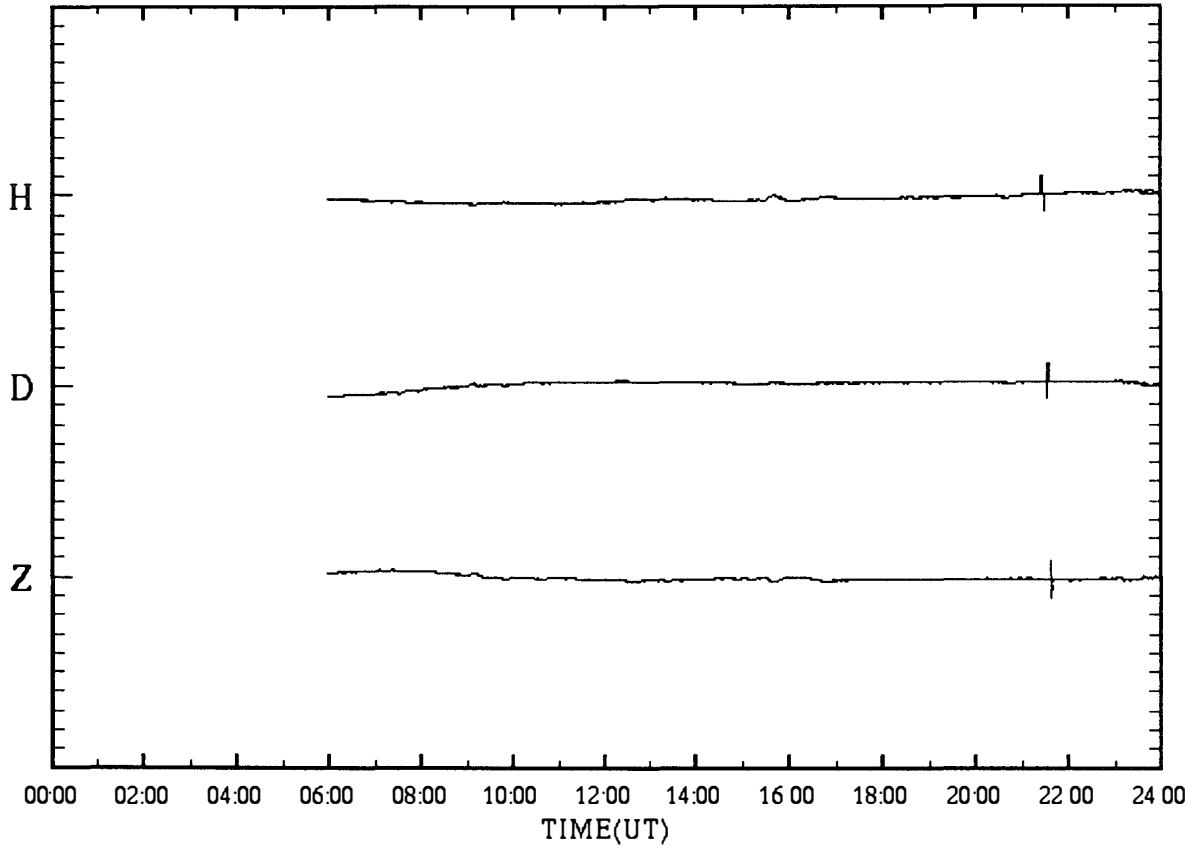

SYOWA magnetogram (100 nT/div)

24 Jan.1997 (DAY:024)

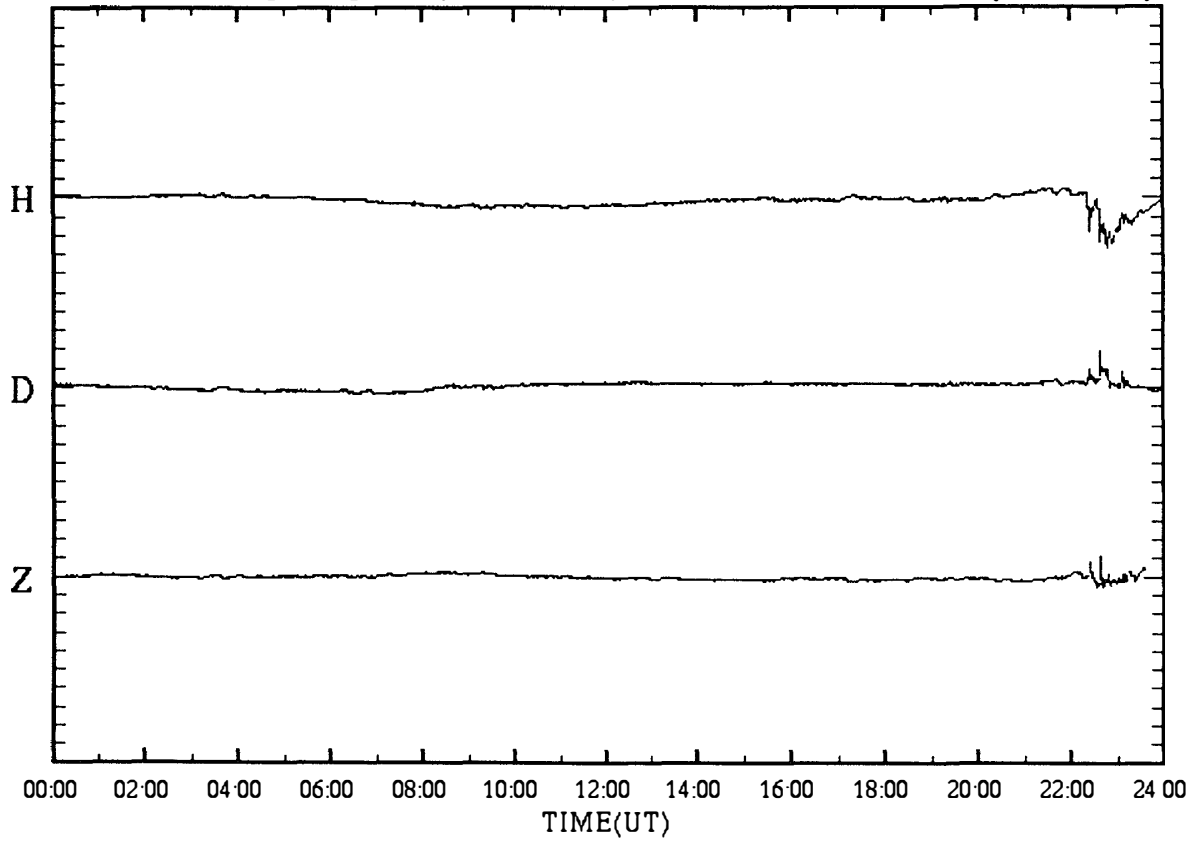

SYOWA magnetogram (100 nT/div)

25 Jan.1997 (DAY:025)

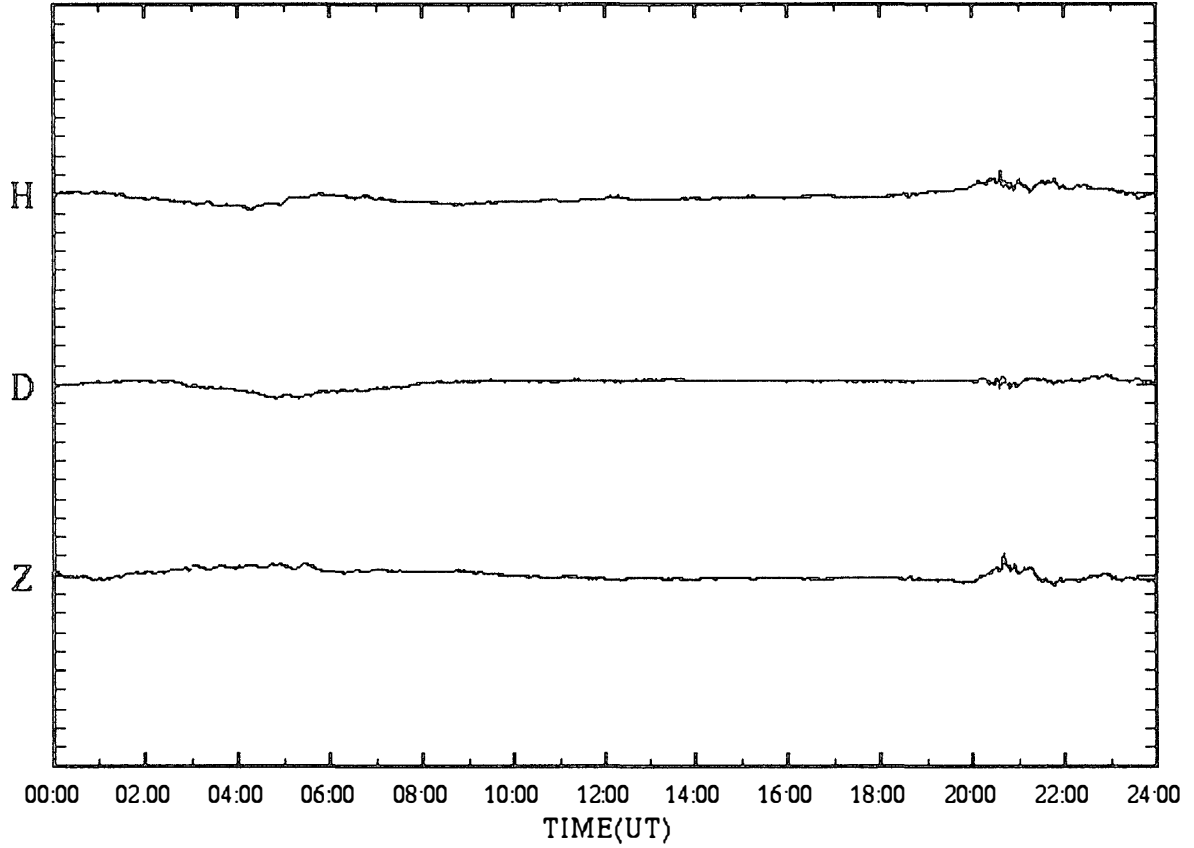

SYOWA magnetogram (100 nT/div)

26 Jan.1997 (DAY:026)

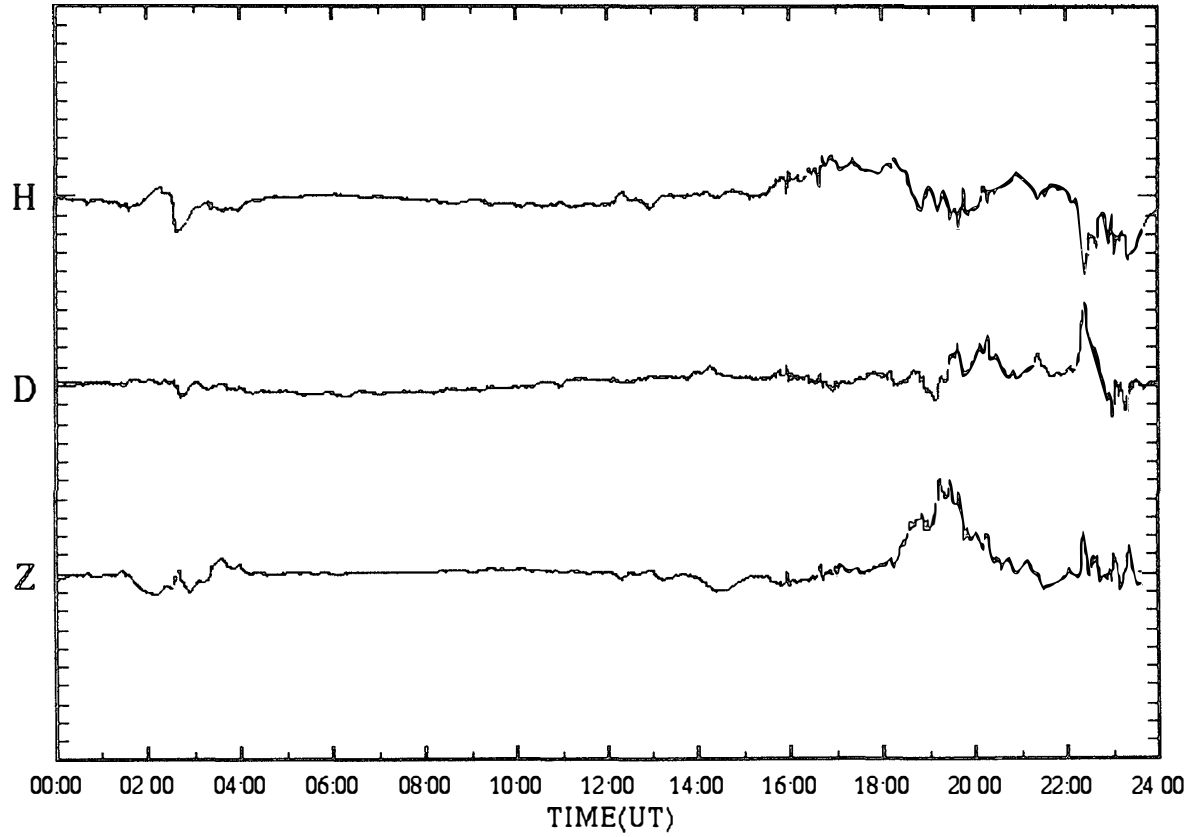

SYOWA magnetogram (100 nT/div)

27 Jan.1997 (DAY:027)

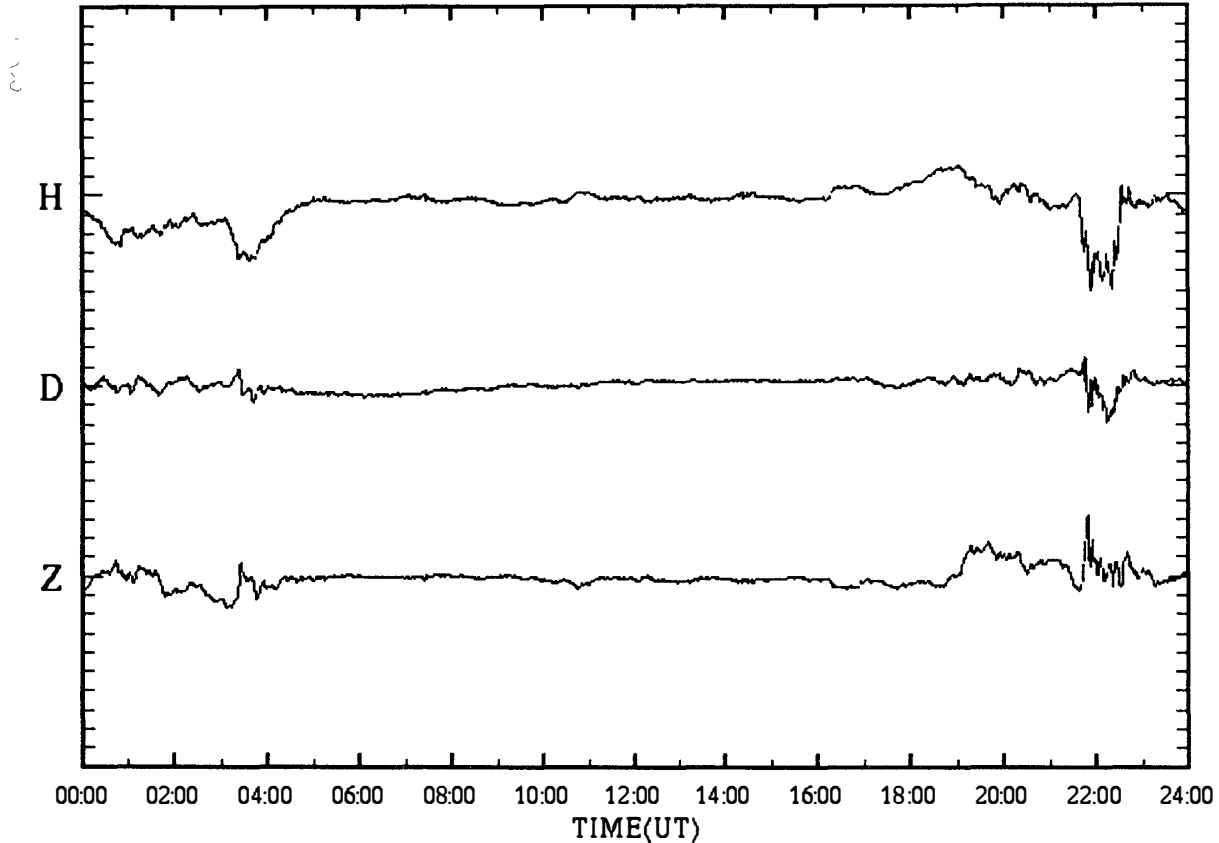

SYOWA magnetogram (100 nT/div)

28 Jan.1997 (DAY:028)

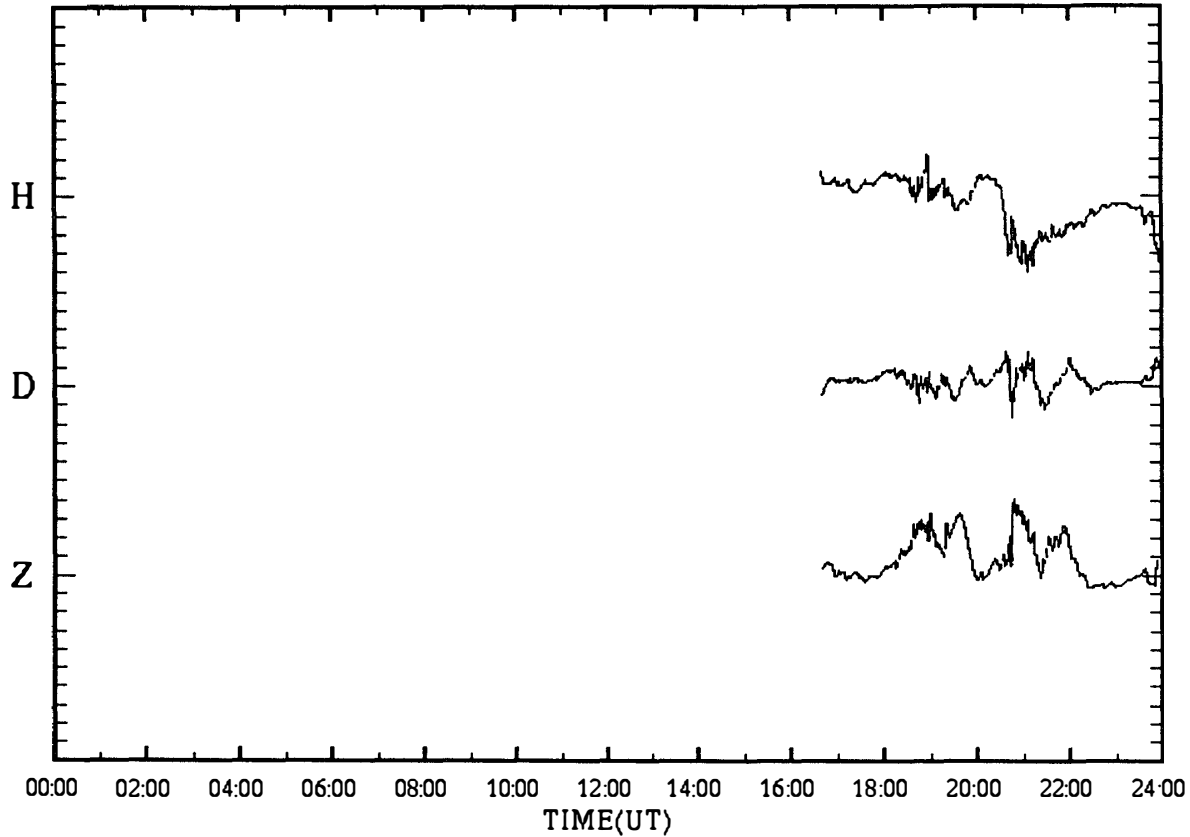

SYOWA magnetogram (100 nT/div)

29 Jan.1997 (DAY:029)

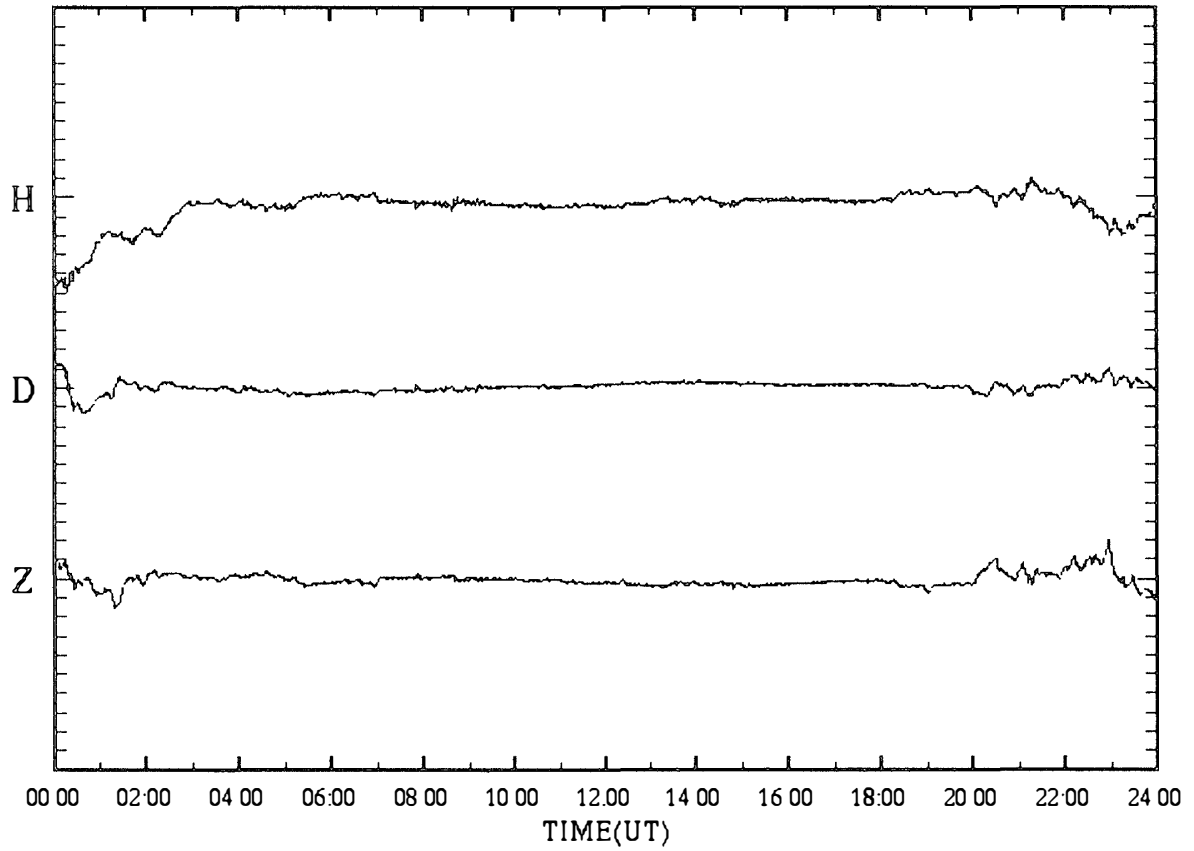

SYOWA magnetogram (100 nT/div)

30 Jan.1997 (DAY:030)

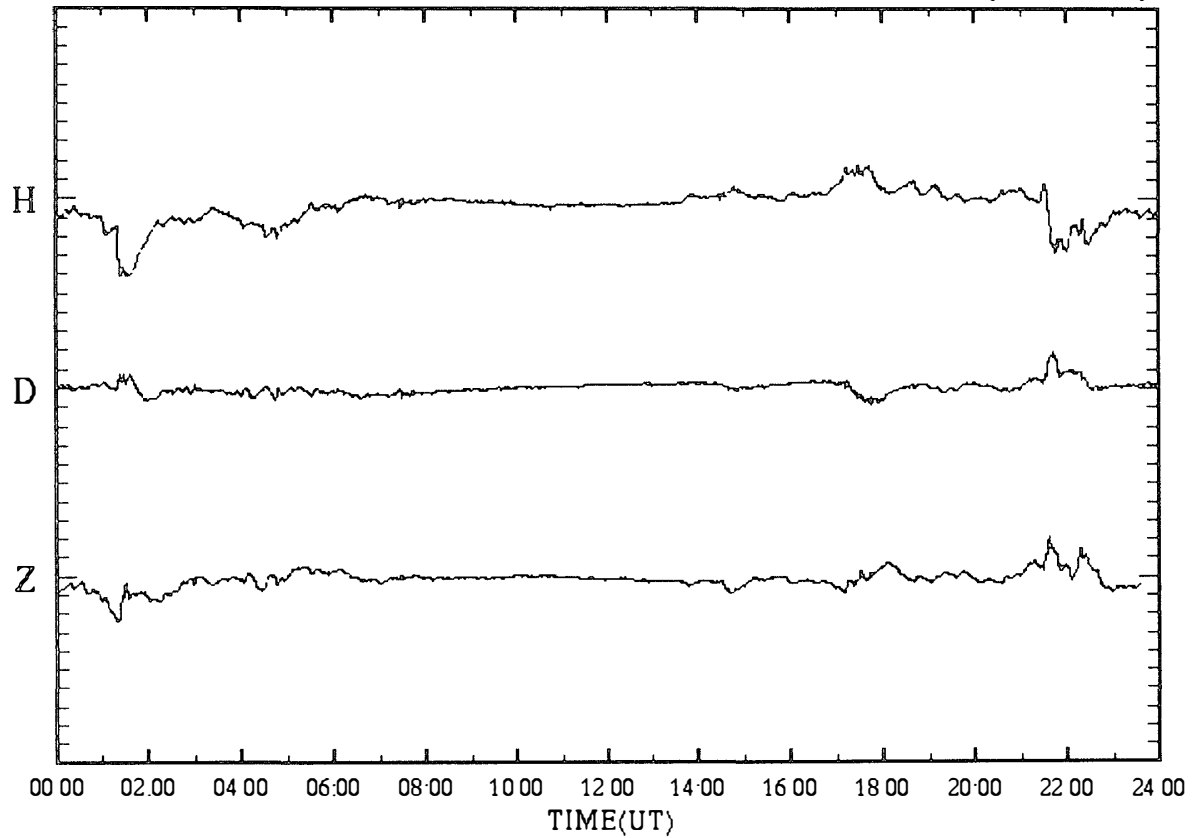

SYOWA magnetogram (100 nT/div)

31 Jan.1997 (DAY:031)

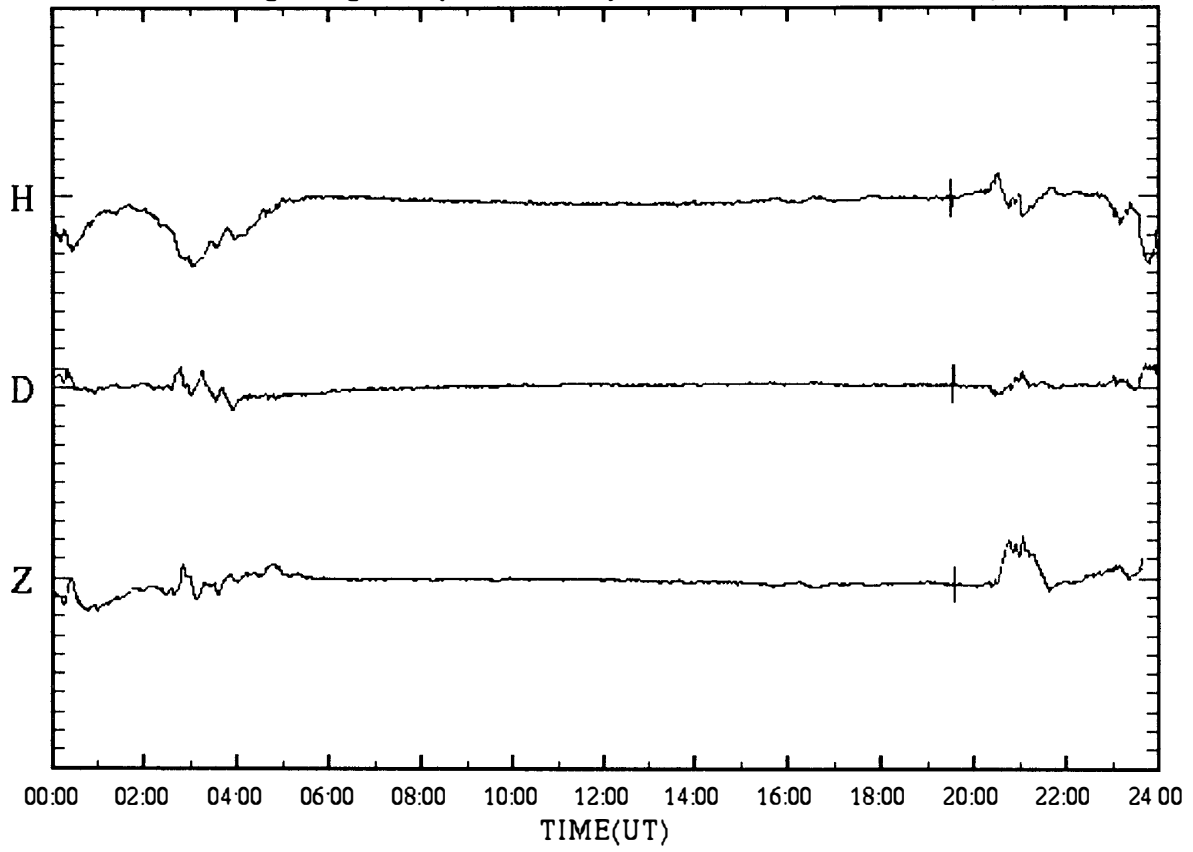

SYOWA magnetogram (100 nT/div)

01 Feb.1997 (DAY:032)

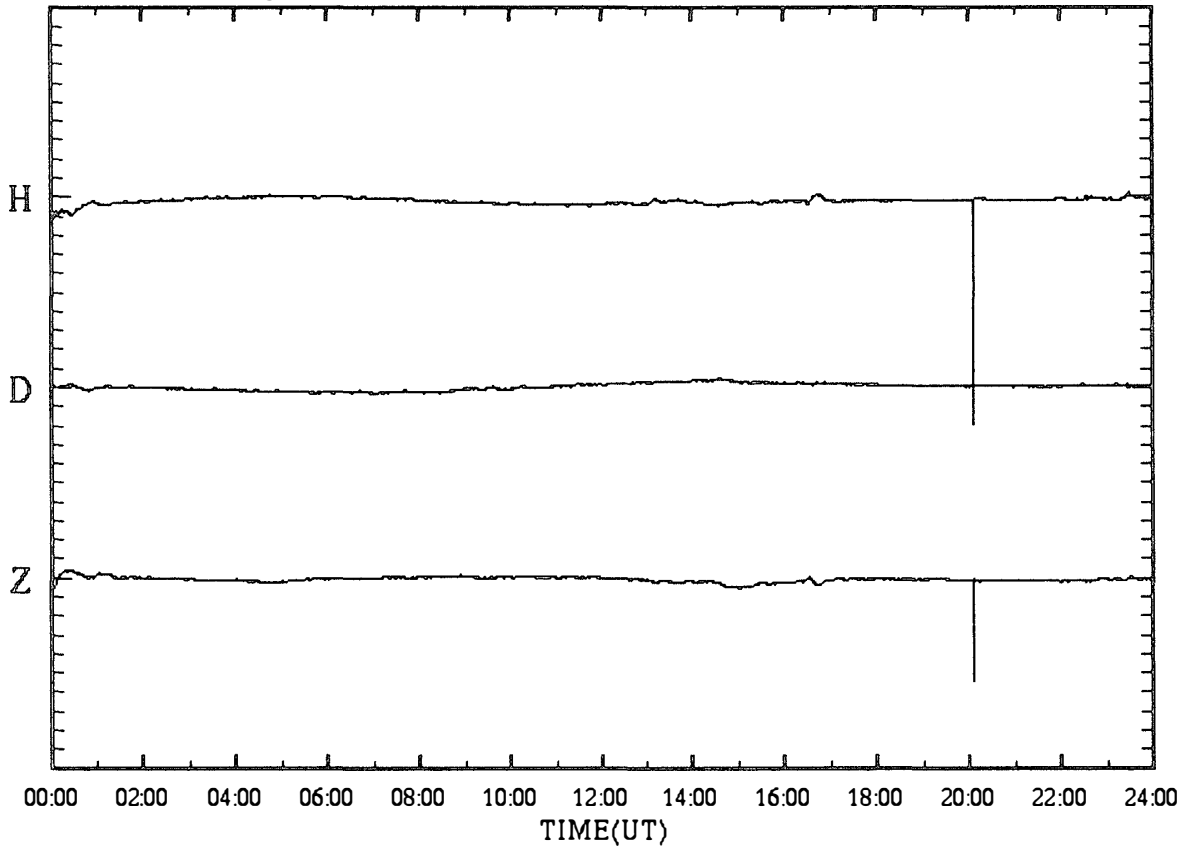

SYOWA magnetogram (100 nT/div)

02 Feb.1997 (DAY:033)

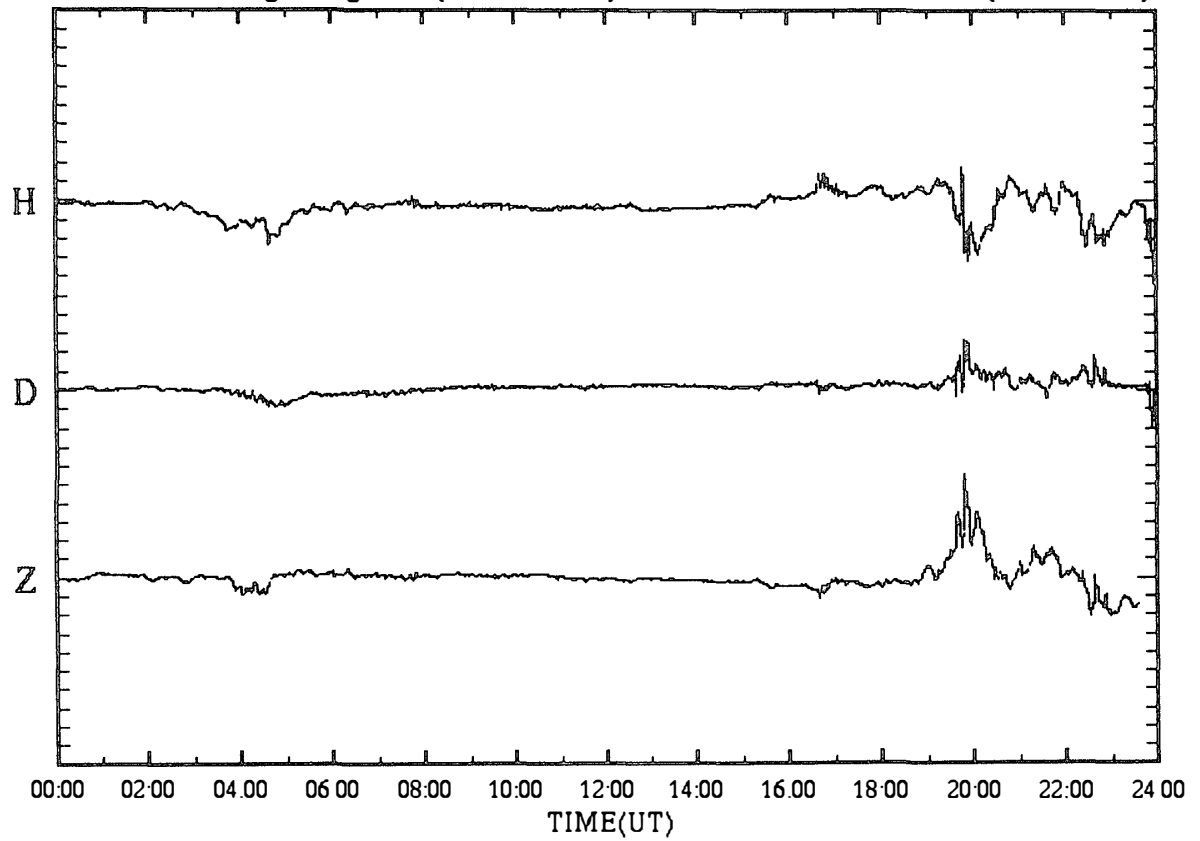

SYOWA magnetogram (100 nT/div)

03 Feb.1997 (DAY:034)

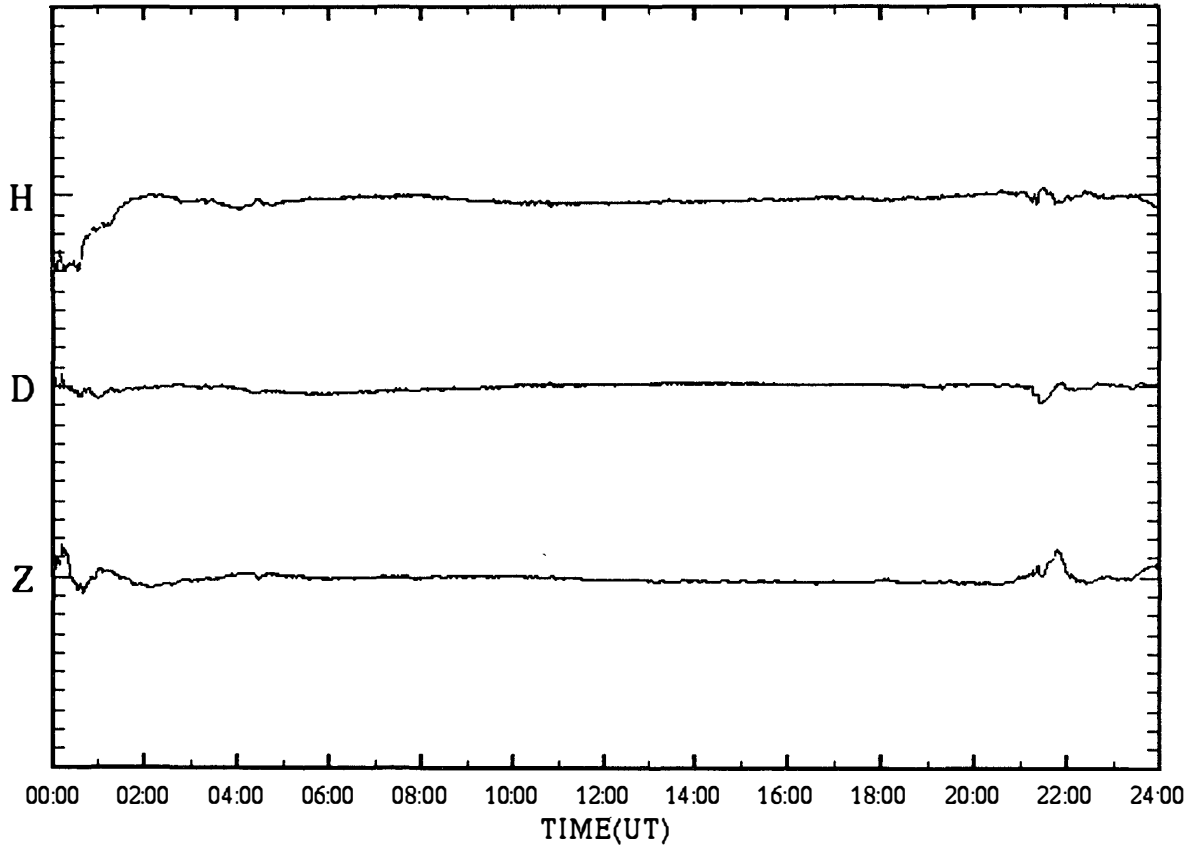

SYOWA magnetogram (100 nT/div)

04 Feb.1997 (DAY:035)

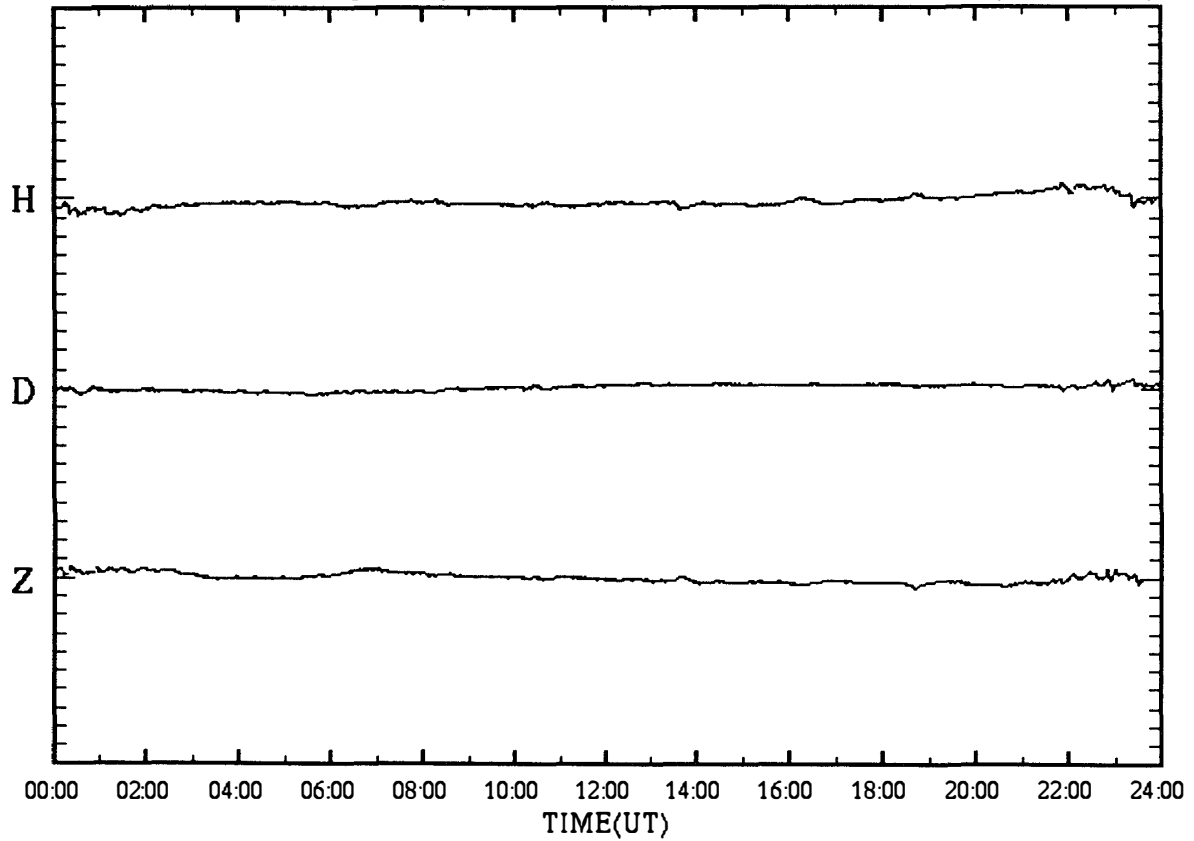

SYOWA magnetogram (100 nT/div)

05 Feb.1997 (DAY:036)

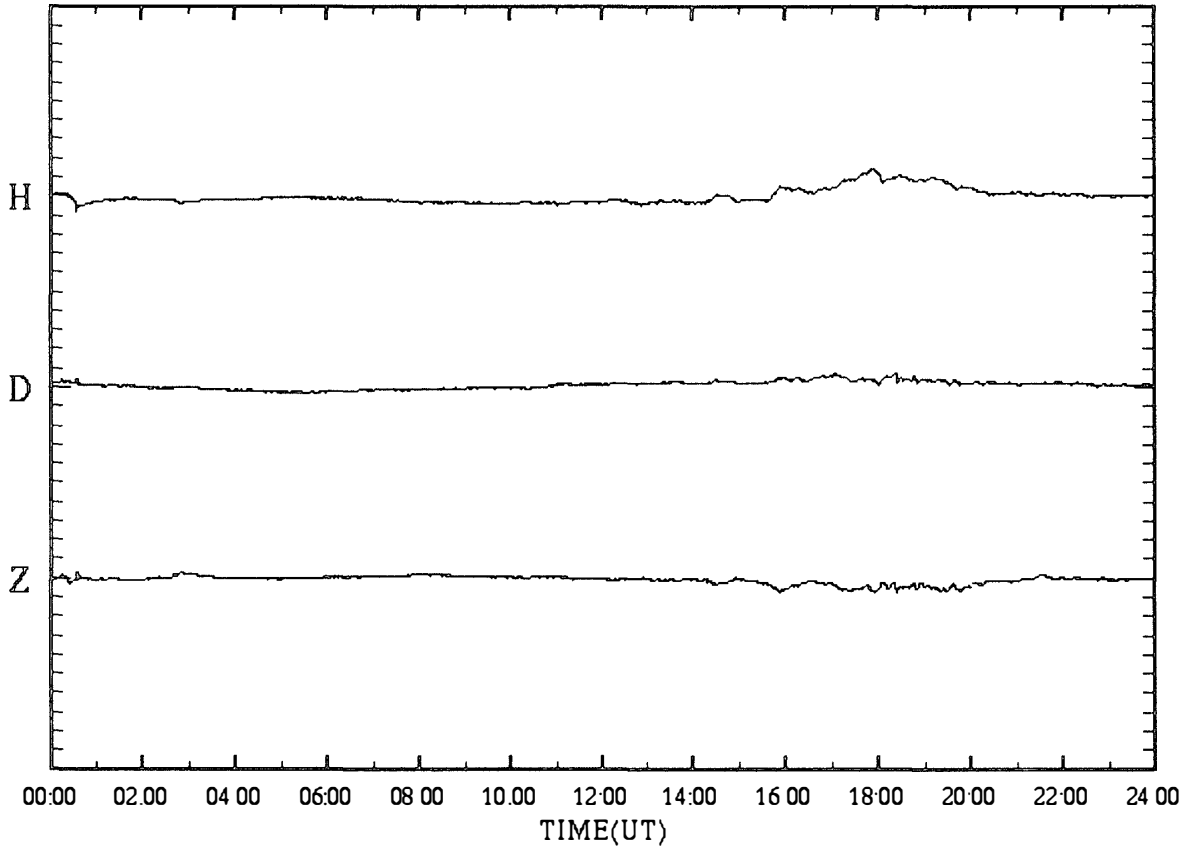

SYOWA magnetogram (100 nT/div)

06 Feb.1997 (DAY:037)

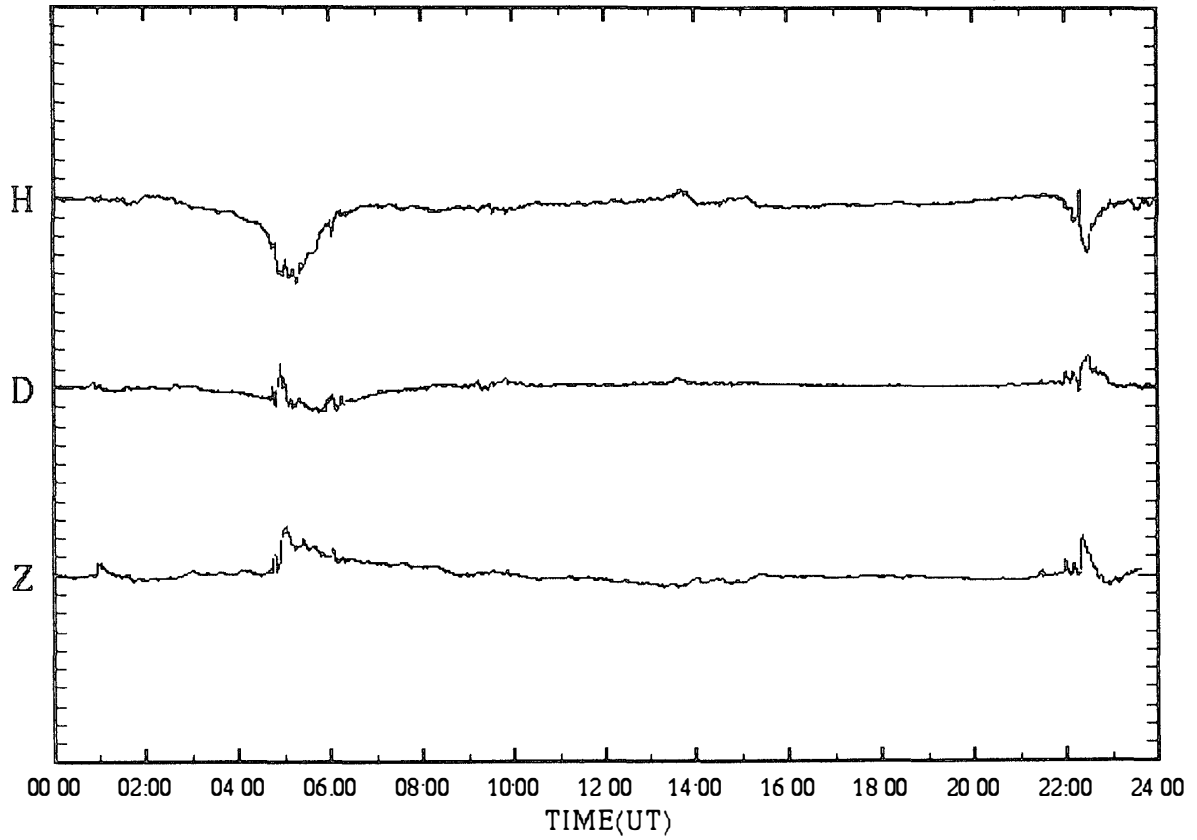



SYOWA magnetogram (100 nT/div)

07 Feb.1997 (DAY:038)

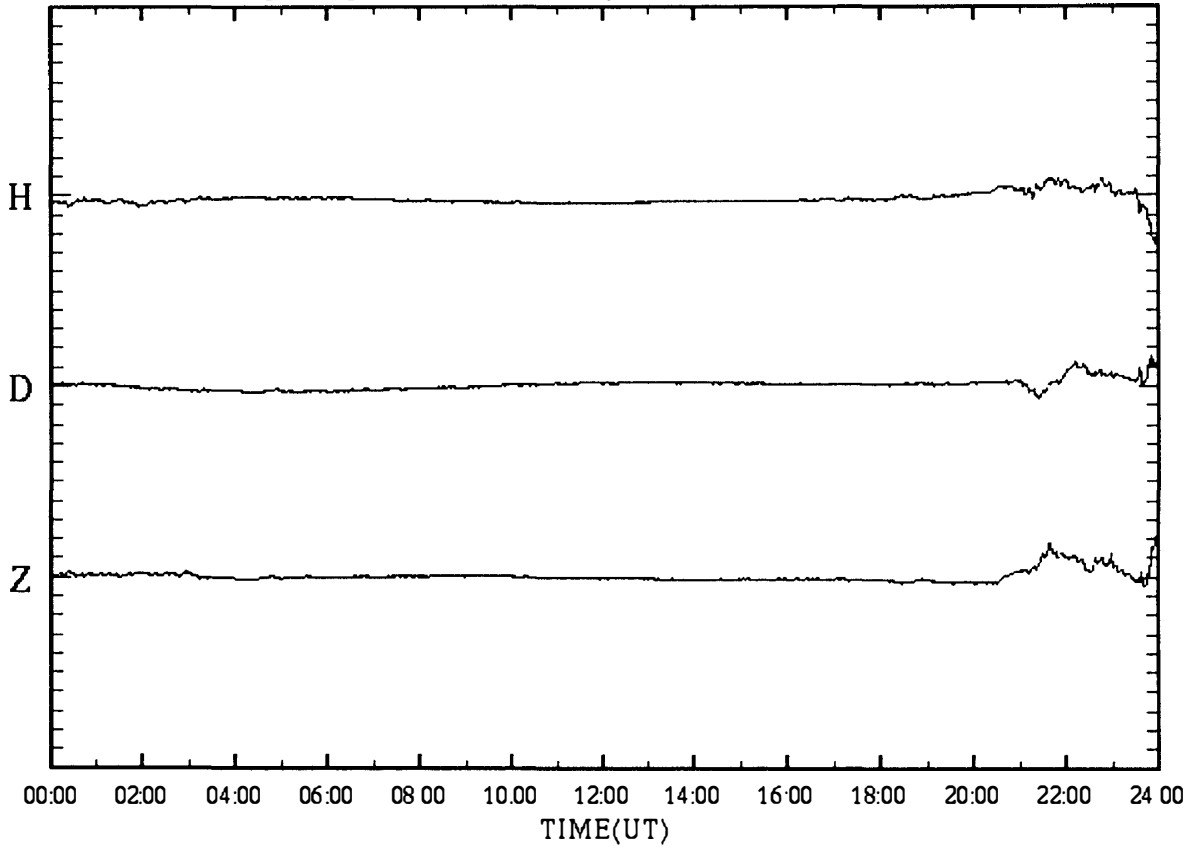

SYOWA magnetogram (100 nT/div)

08 Feb.1997 (DAY:039)

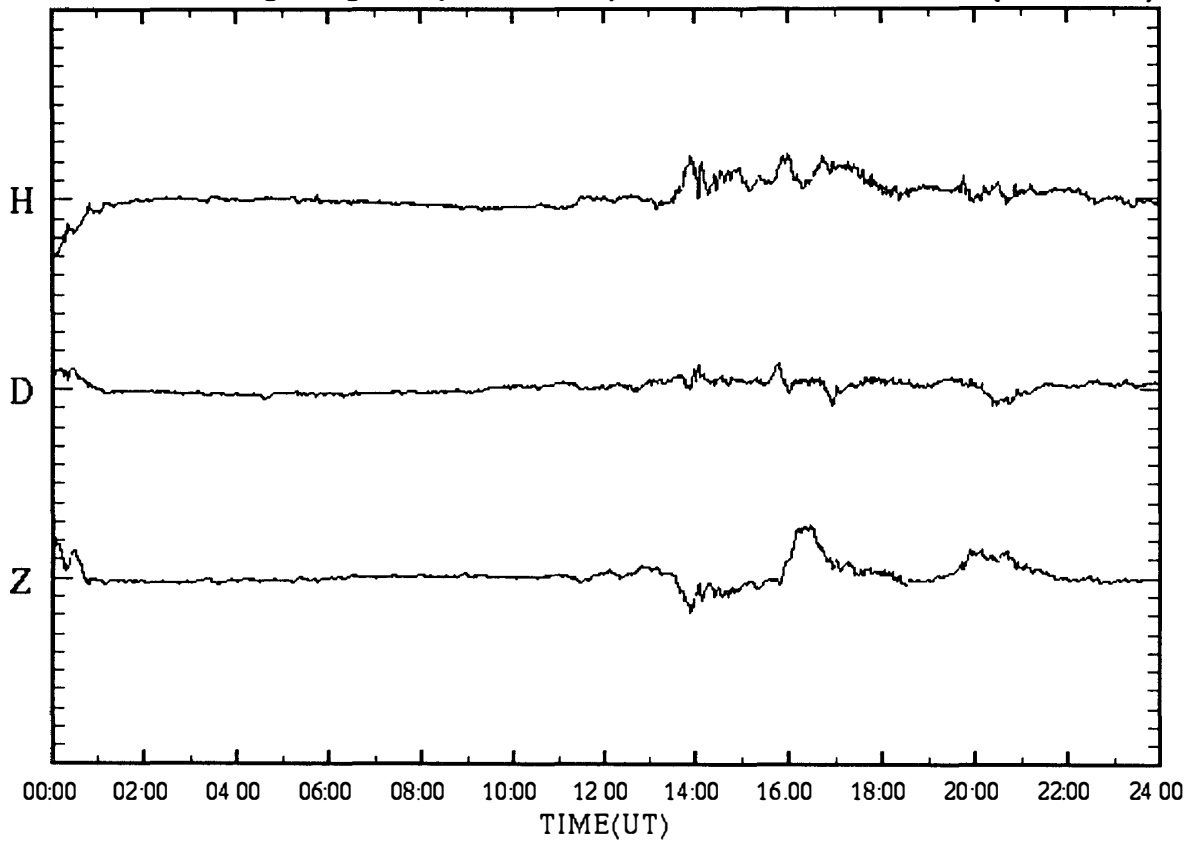

SYOWA magnetogram (100 nT/div)

09 Feb.1997 (DAY:040)

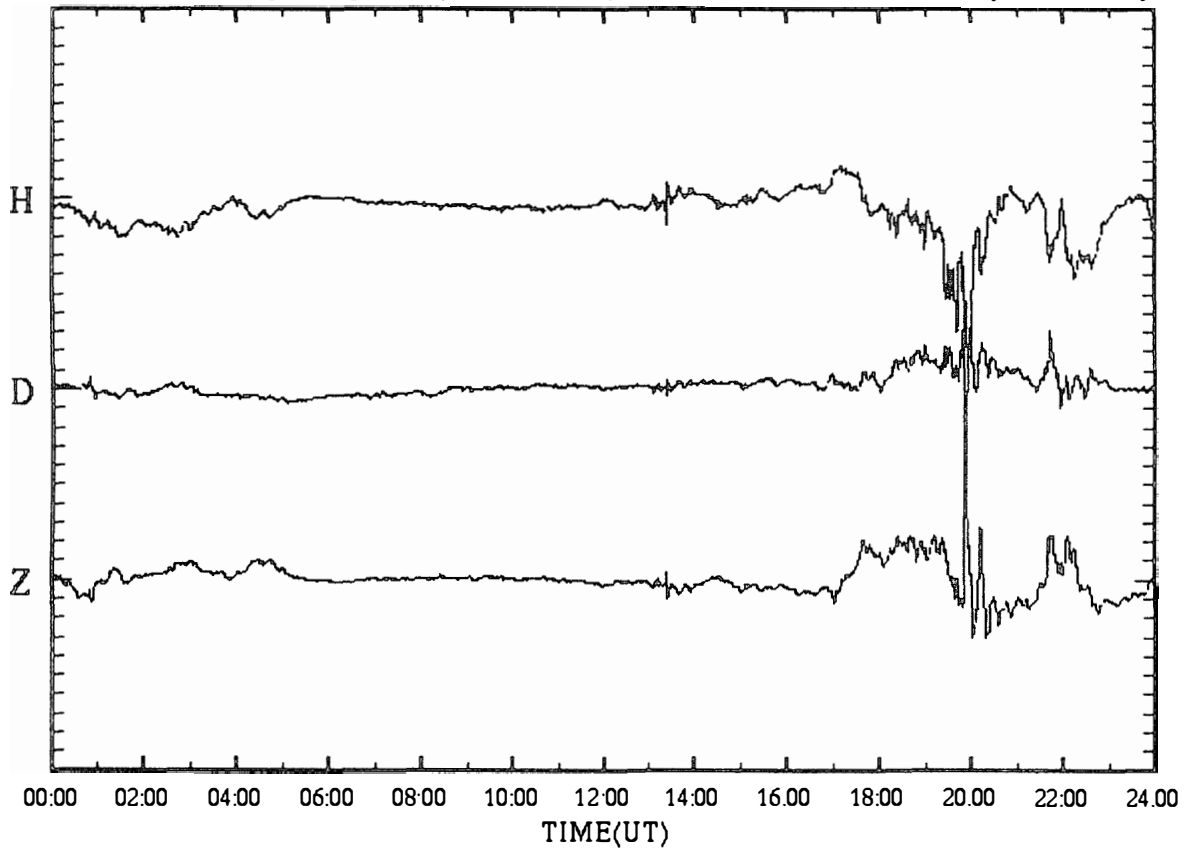

SYOWA magnetogram (100 nT/div)

10 Feb.1997 (DAY:041)

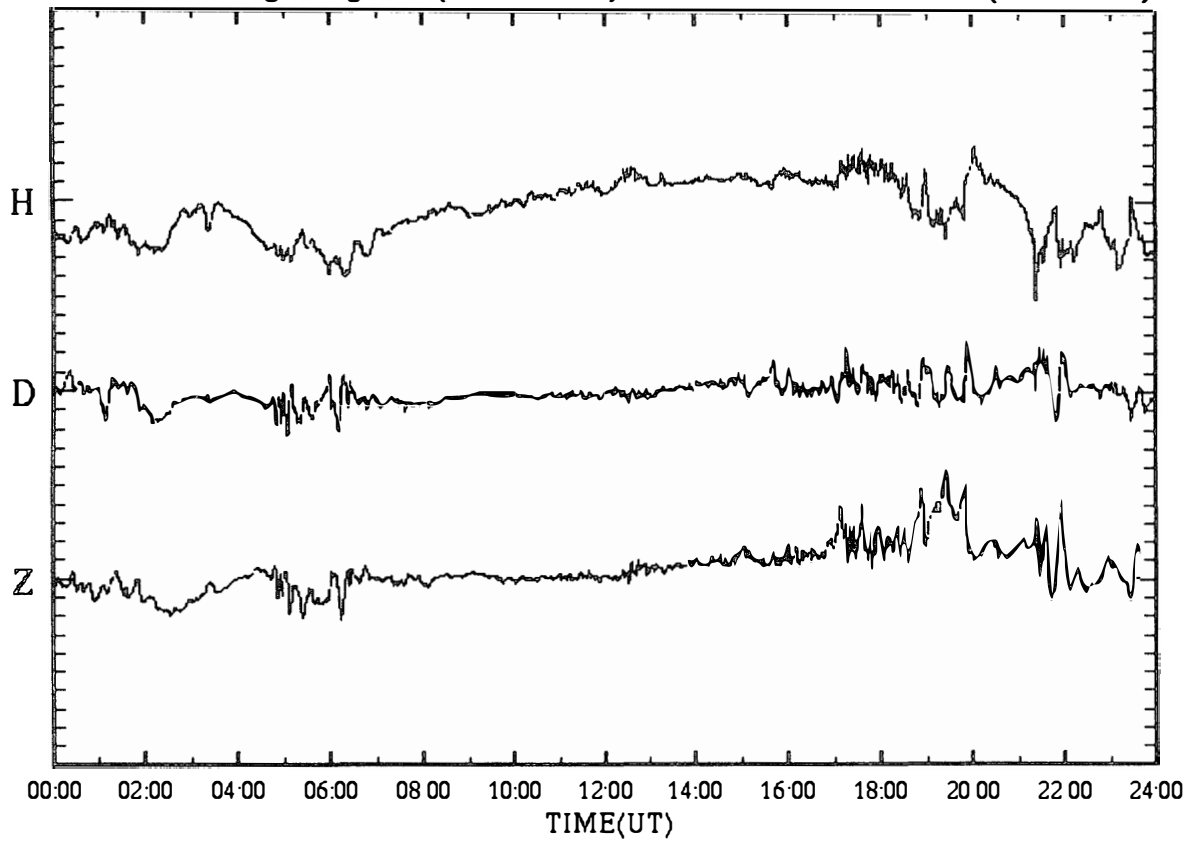

SYOWA magnetogram (100 nT/div)

11 Feb.1997 (DAY:042)

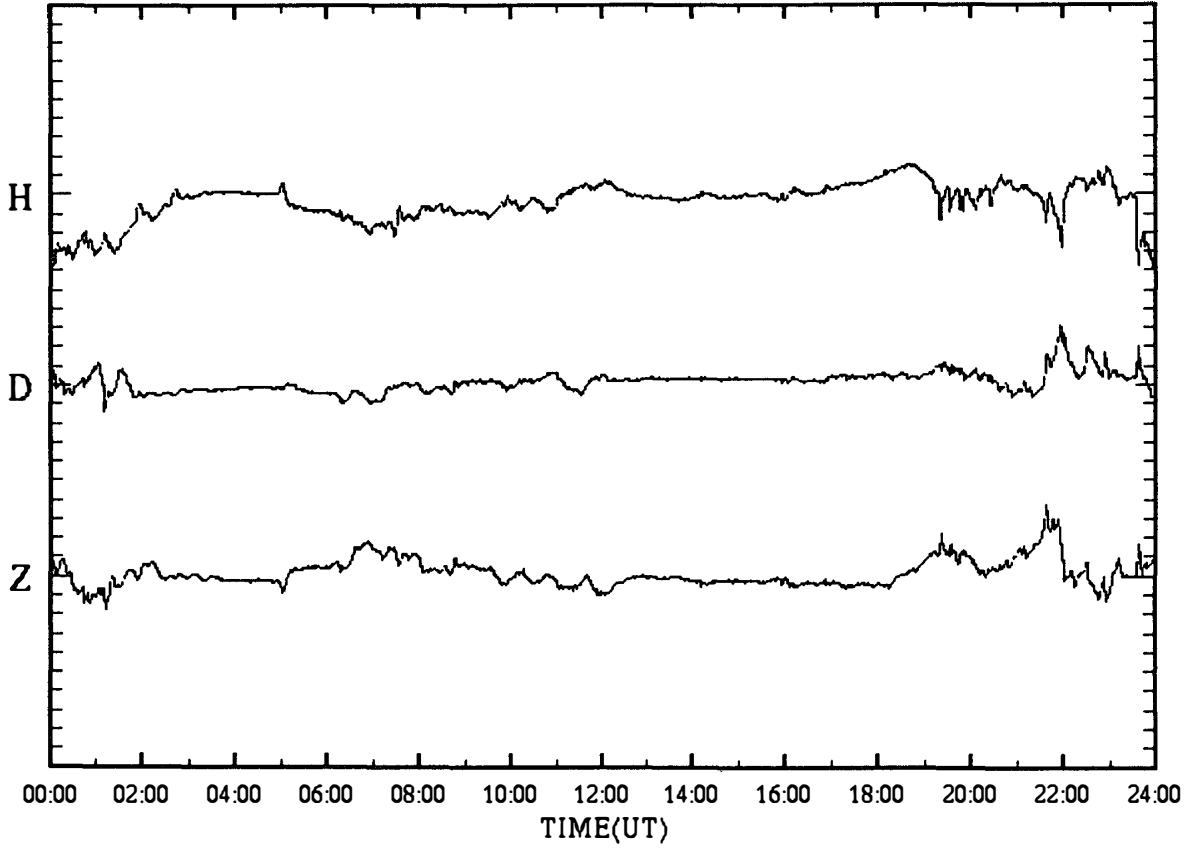

SYOWA magnetogram (100 nT/div)

12 Feb.1997 (DAY:043)

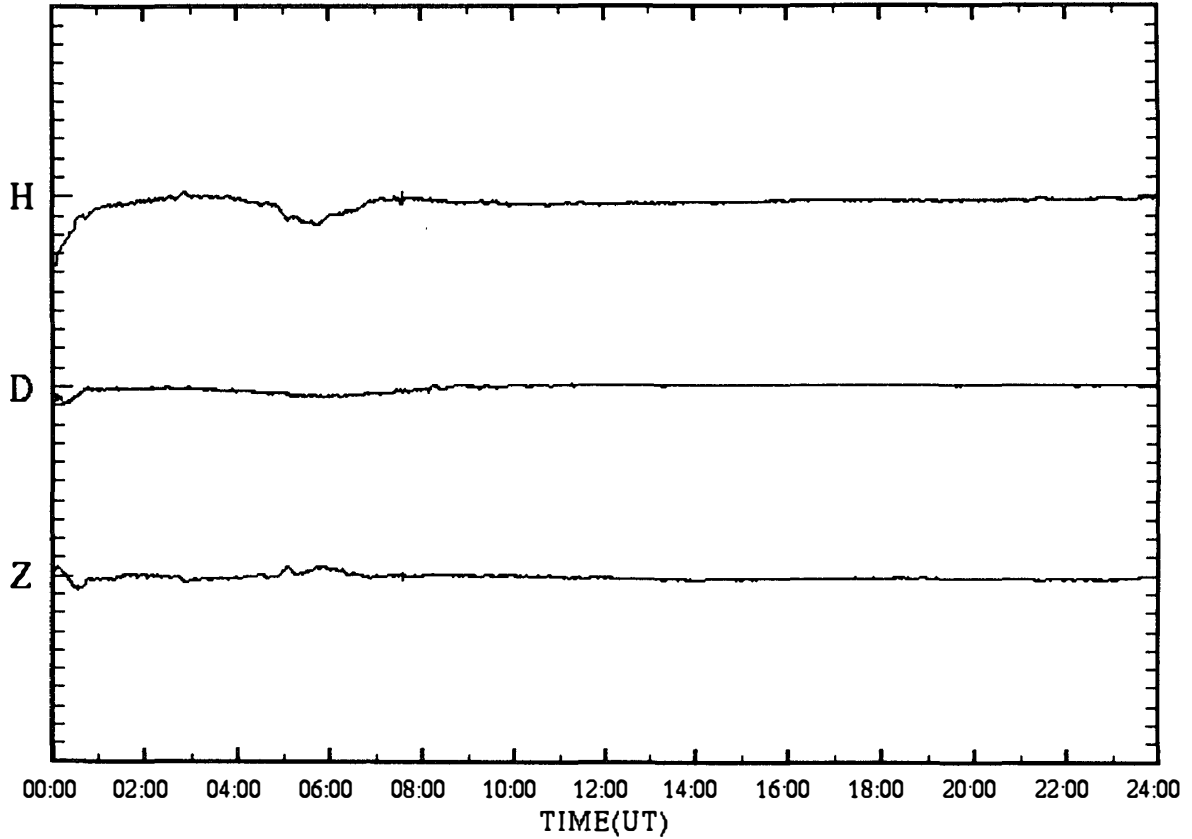

SYOWA magnetogram (100 nT/div)

13 Feb.1997 (DAY:044)

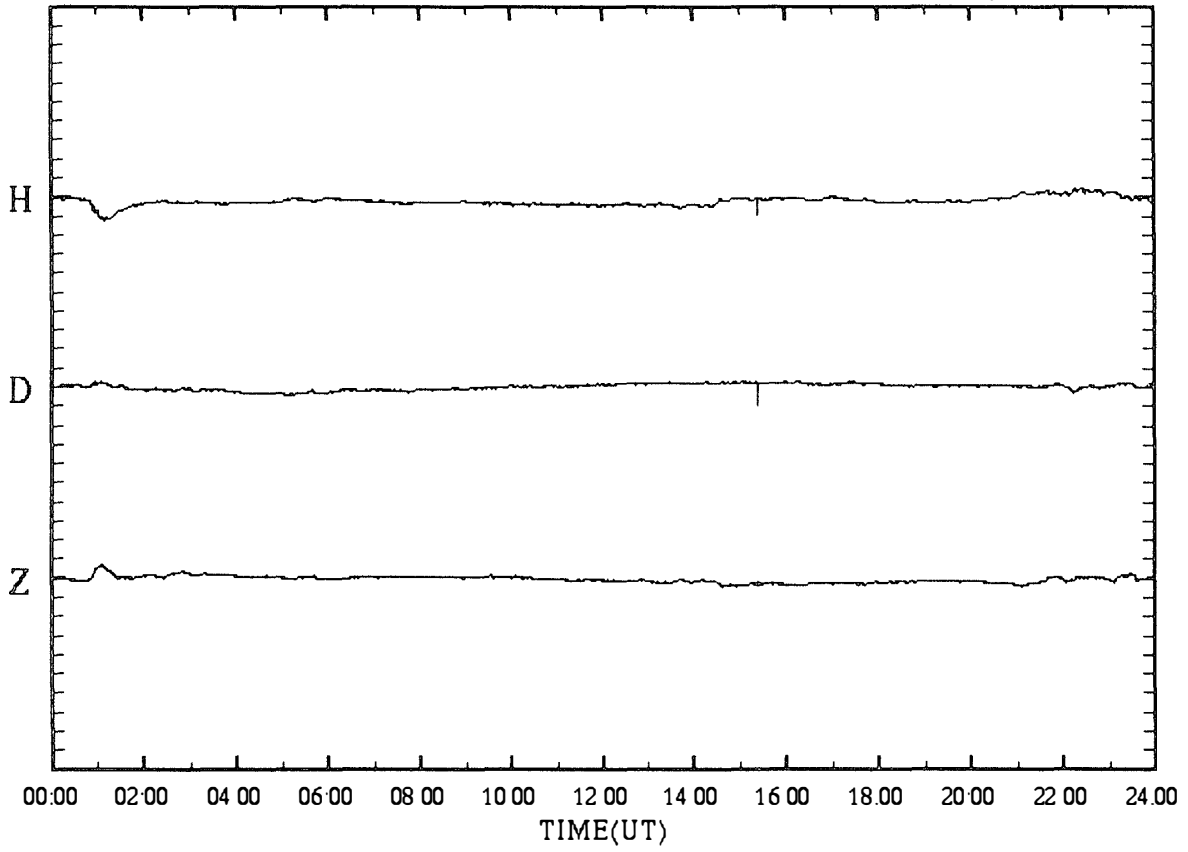

SYOWA magnetogram (100 nT/div)

14 Feb.1997 (DAY:045)

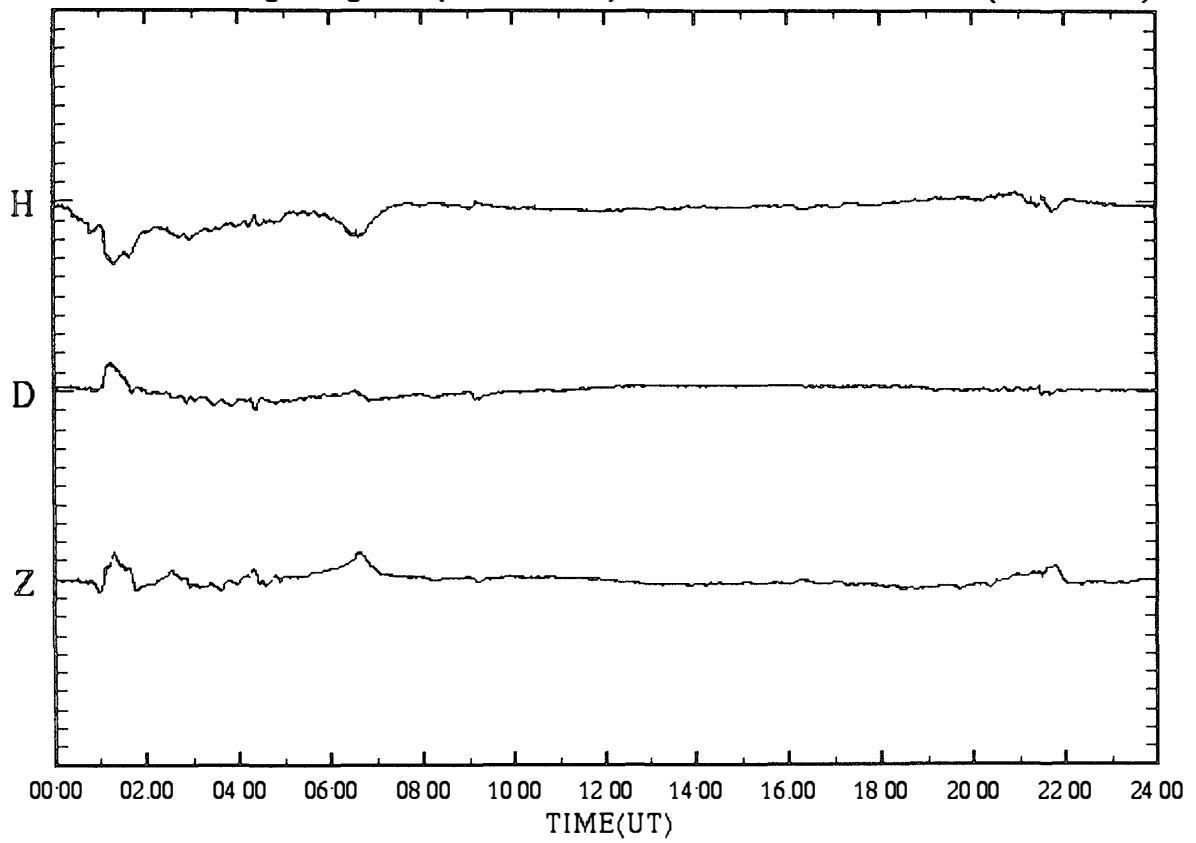

SYOWA magnetogram (100 nT/div)

15 Feb.1997 (DAY:046)

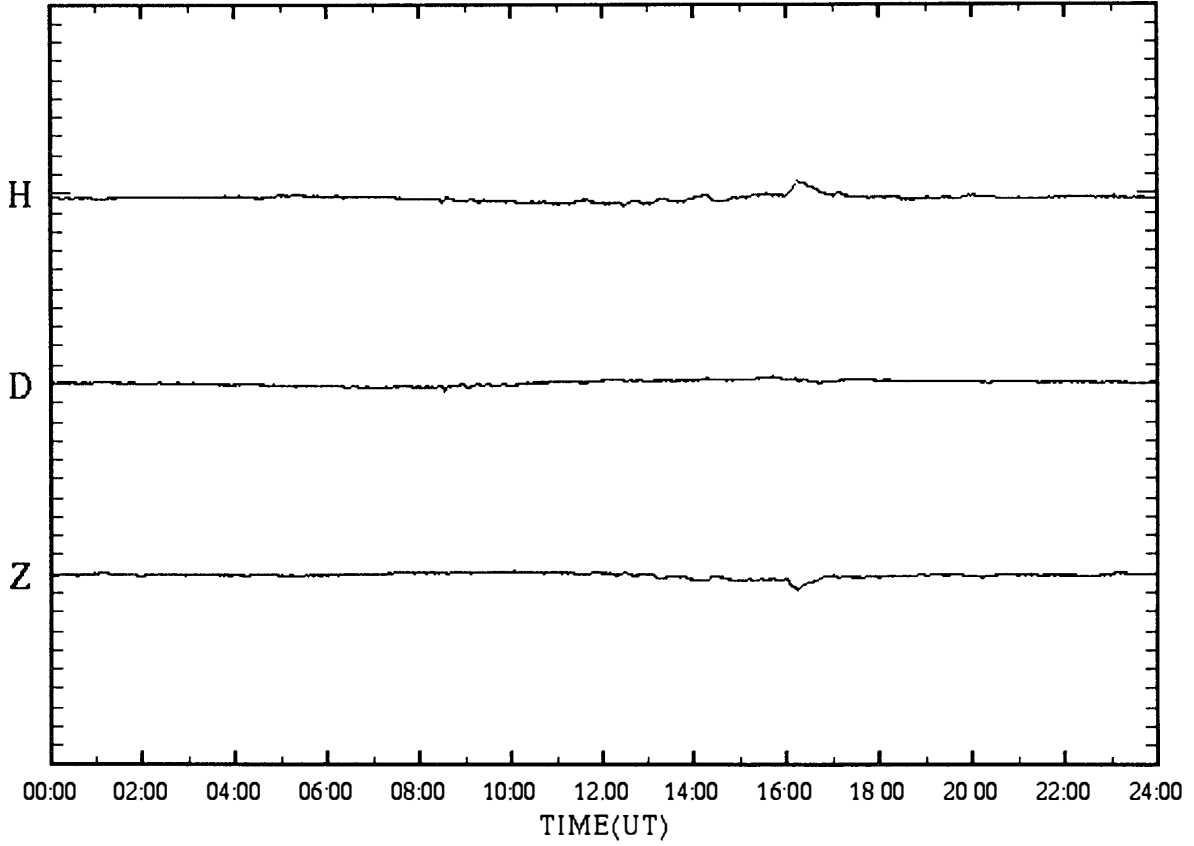

SYOWA magnetogram (100 nT/div)

16 Feb.1997 (DAY:047)

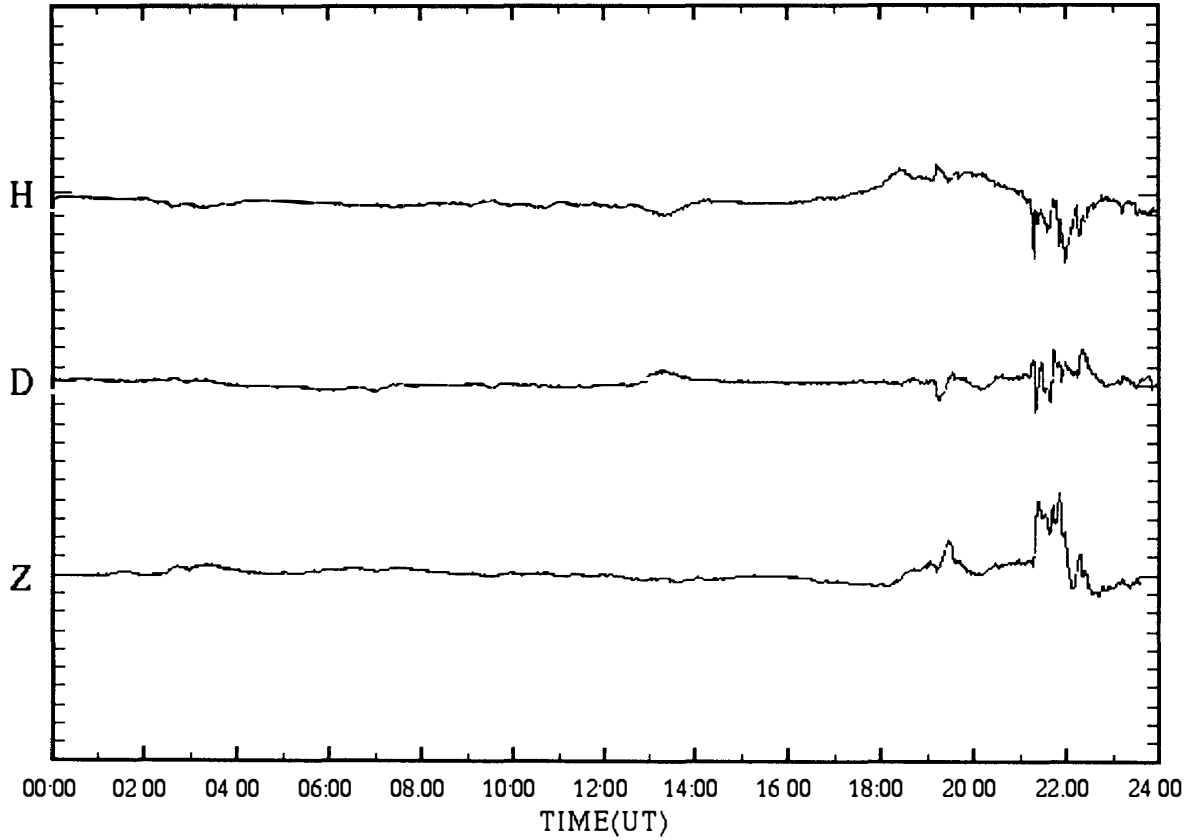

SYOWA magnetogram (100 nT/div)

17 Feb.1997 (DAY:048)

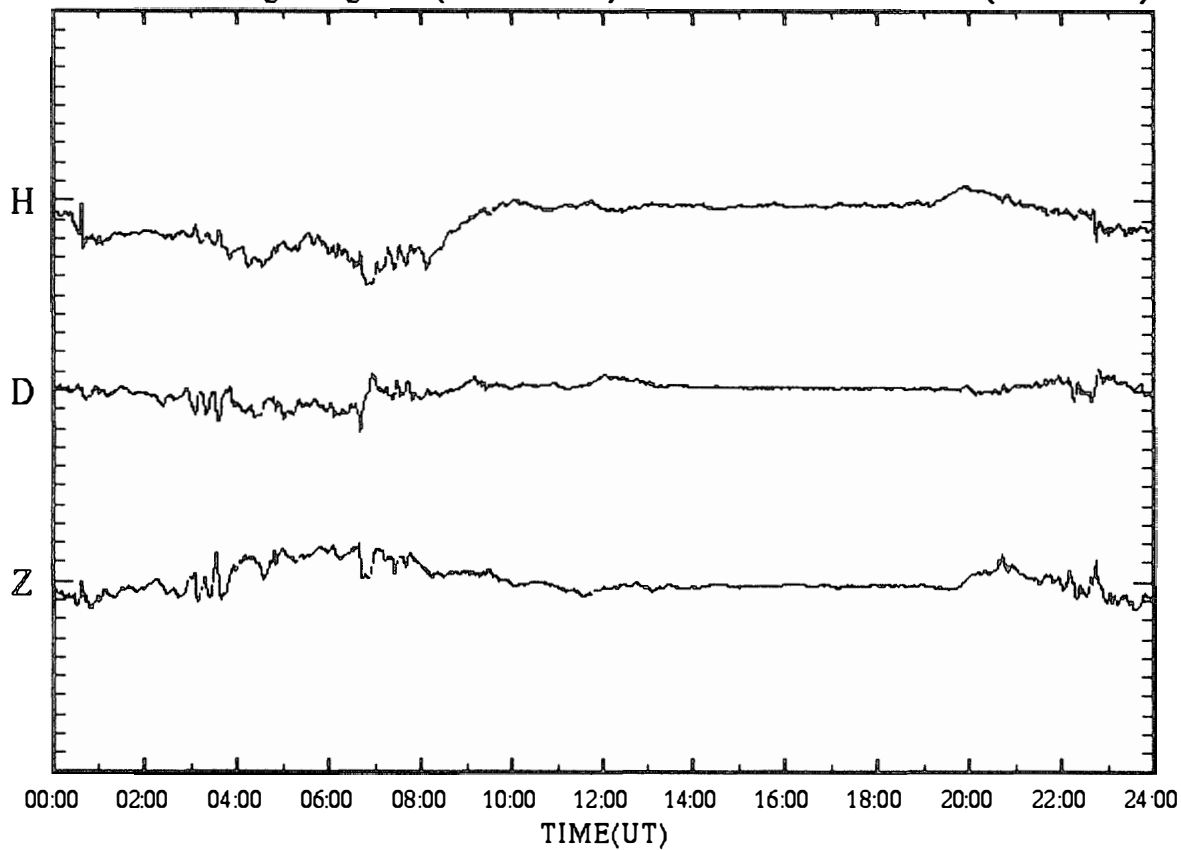

SYOWA magnetogram (100 nT/div)

18 Feb.1997 (DAY:049)

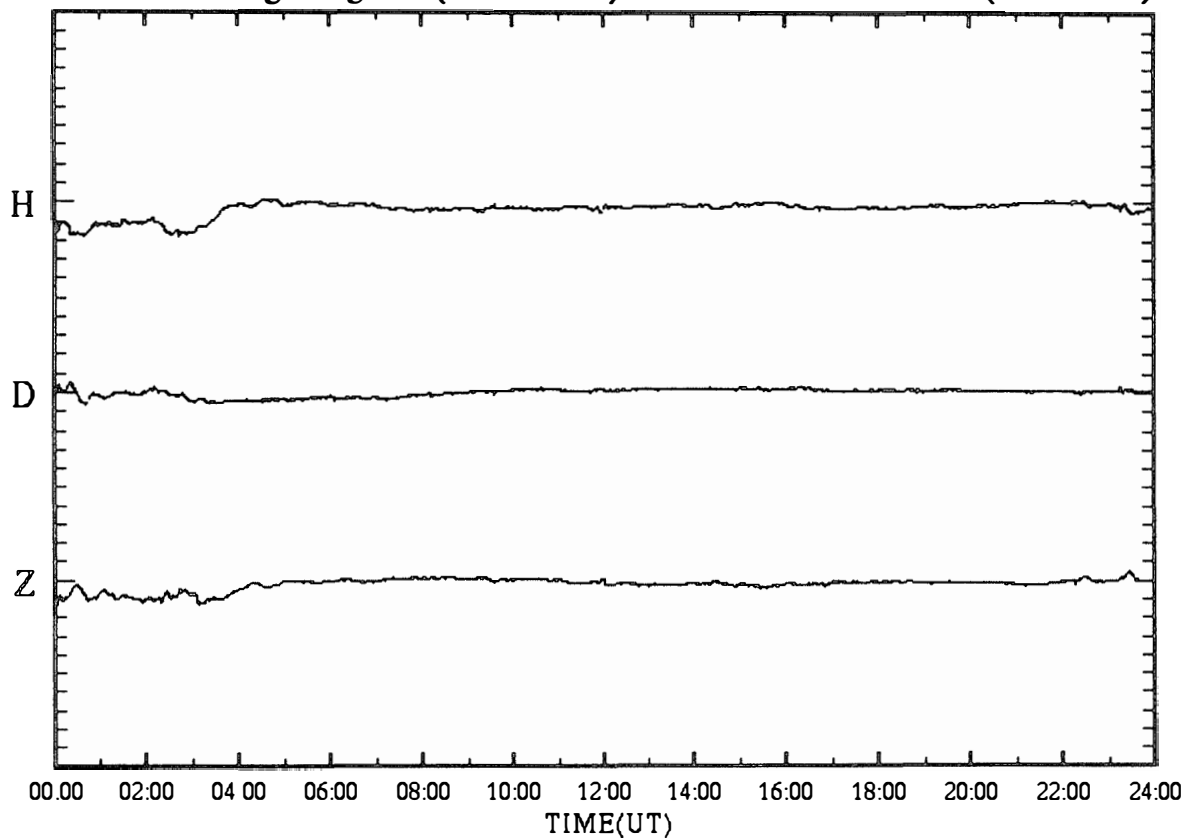

SYOWA magnetogram (100 nT/div)

19 Feb.1997 (DAY:050)

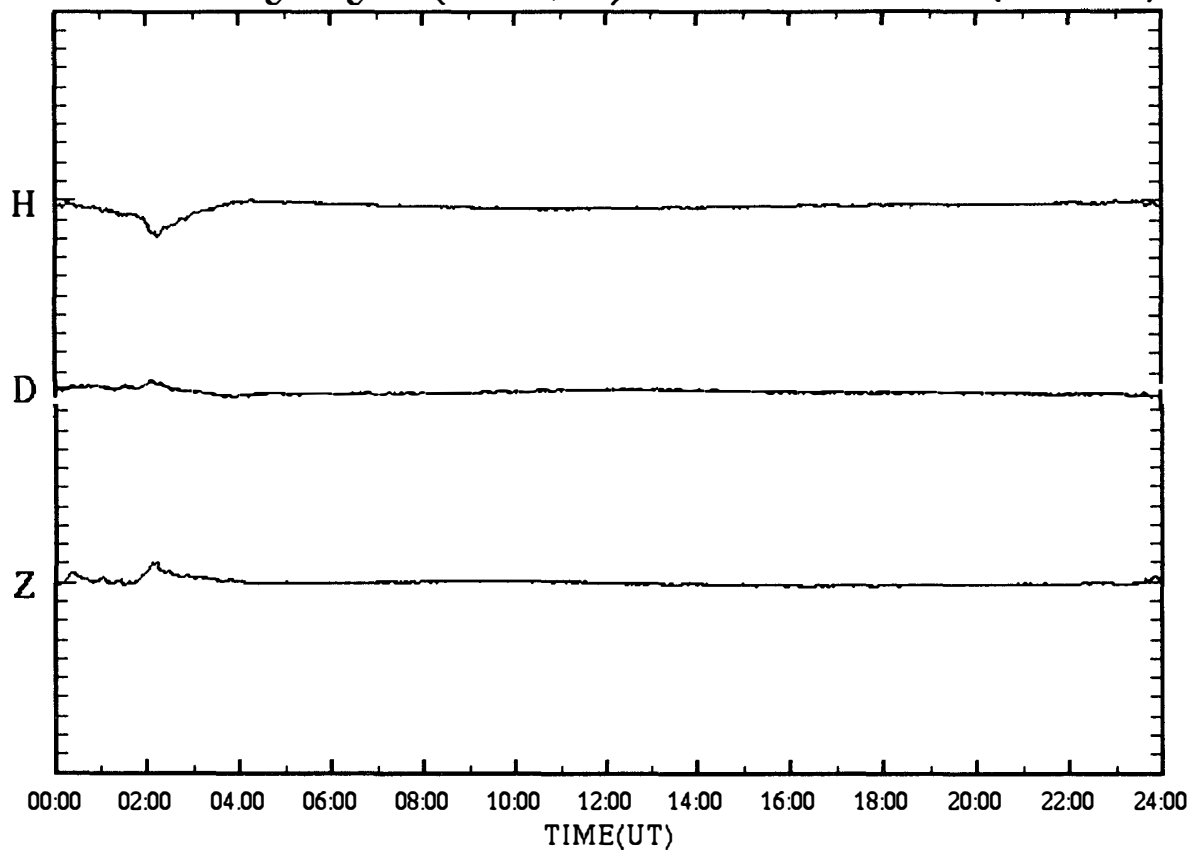

SYOWA magnetogram (100 nT/div)

20 Feb.1997 (DAY:051)

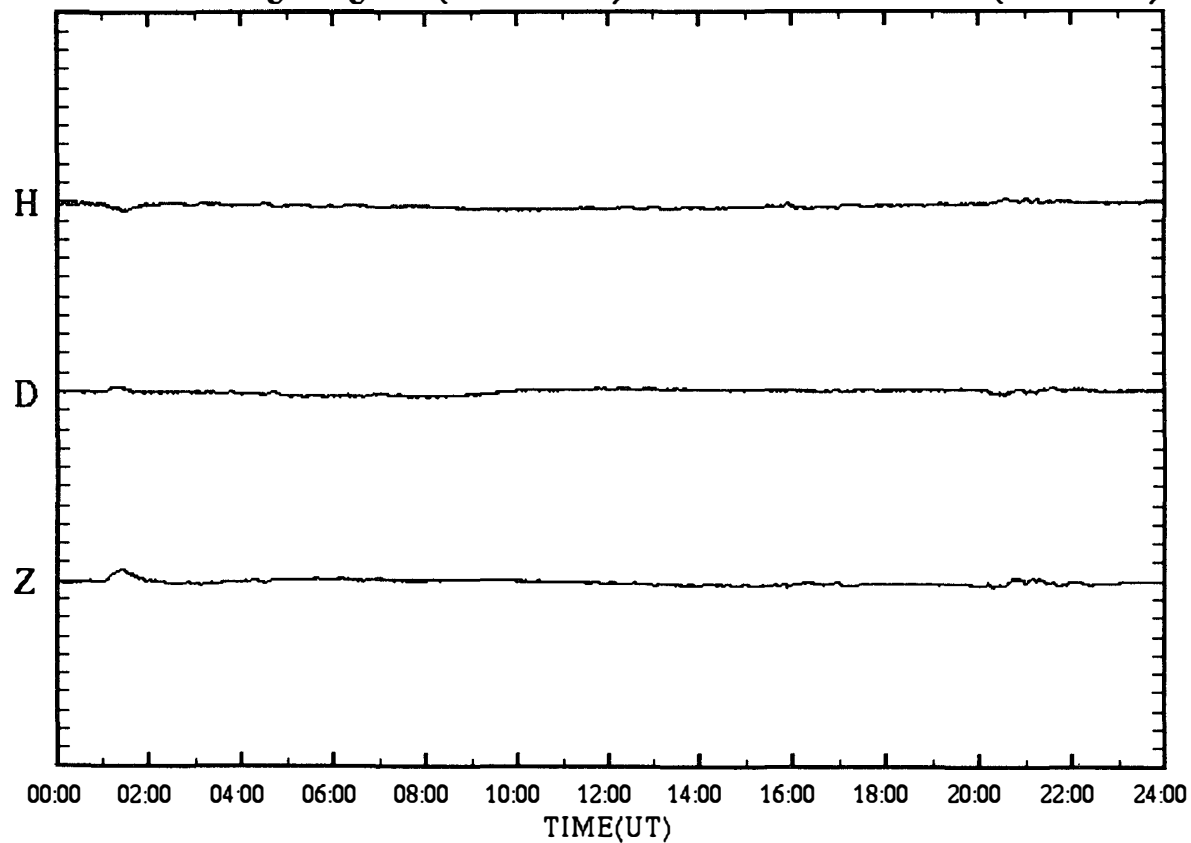

SYOWA magnetogram (100 nT/div)

21 Feb.1997 (DAY:052)

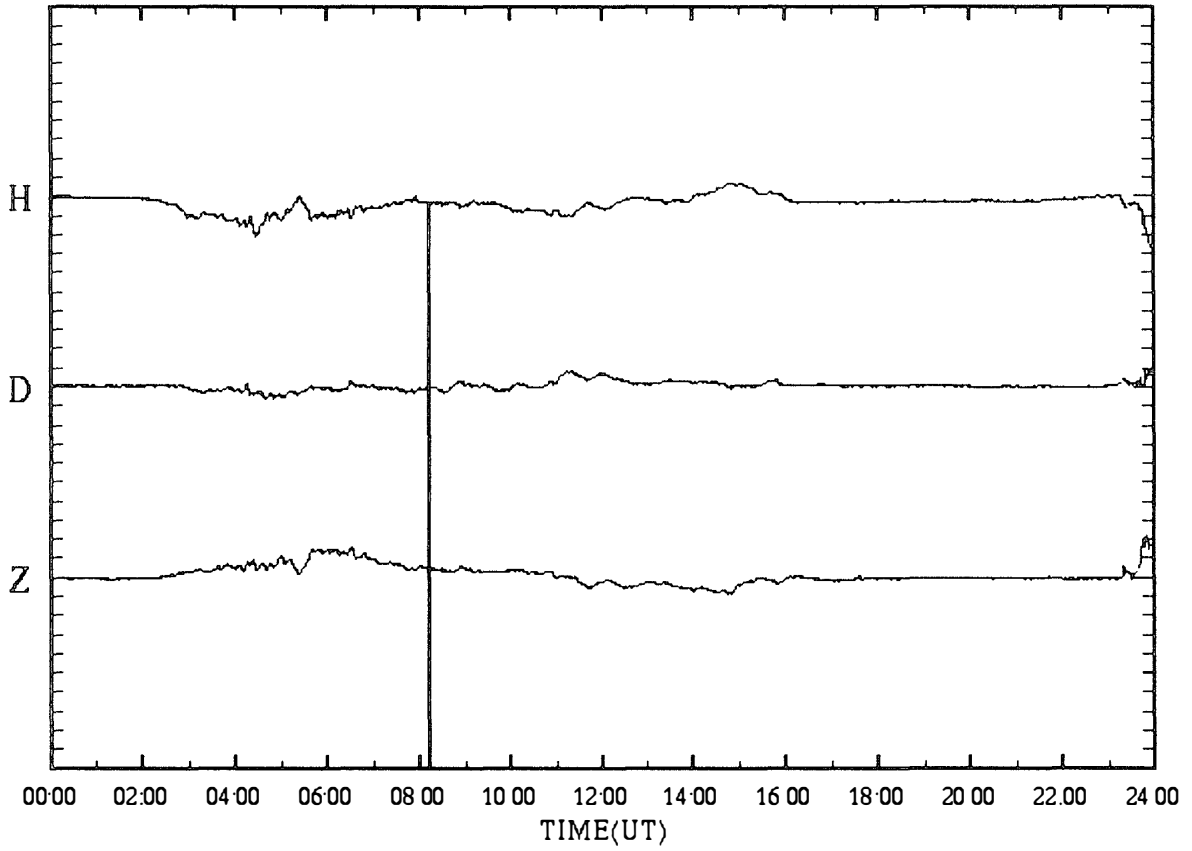

SYOWA magnetogram (100 nT/div)

22 Feb.1997 (DAY:053)

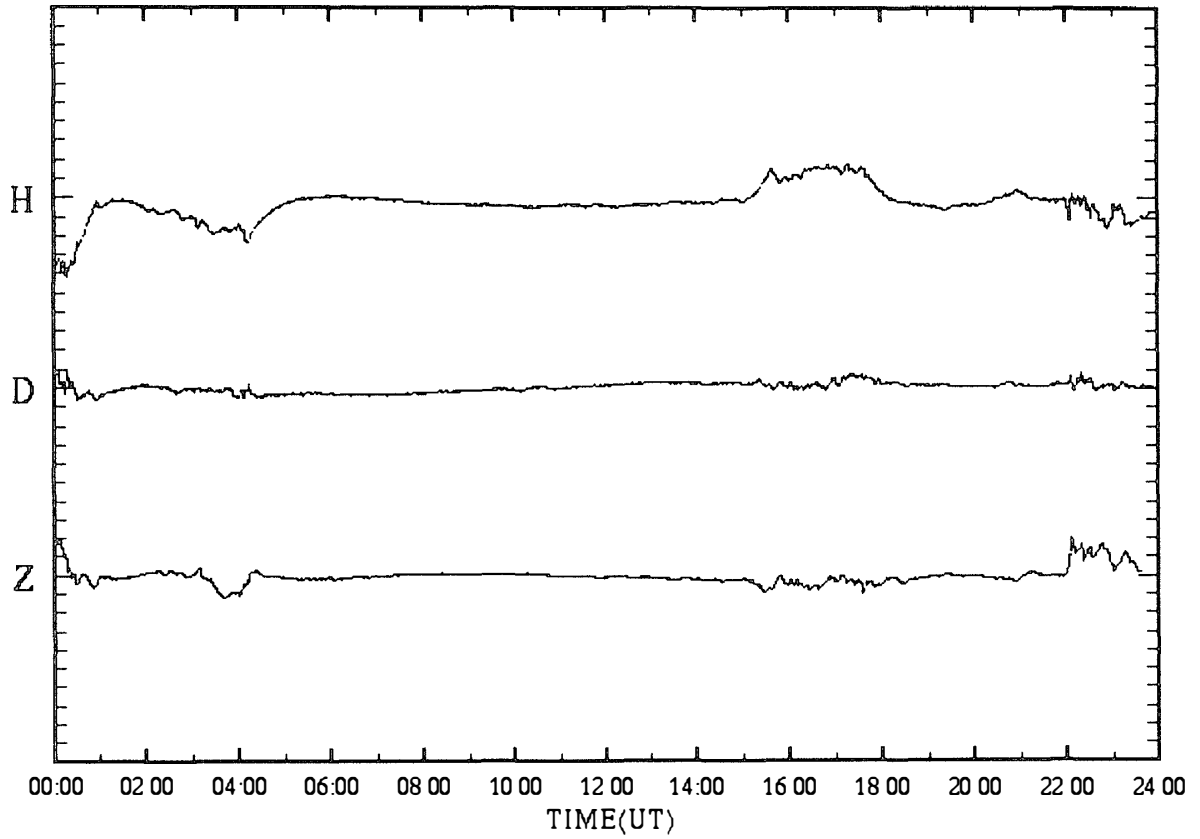



SYOWA magnetogram (100 nT/div)

23 Feb.1997 (DAY:054)

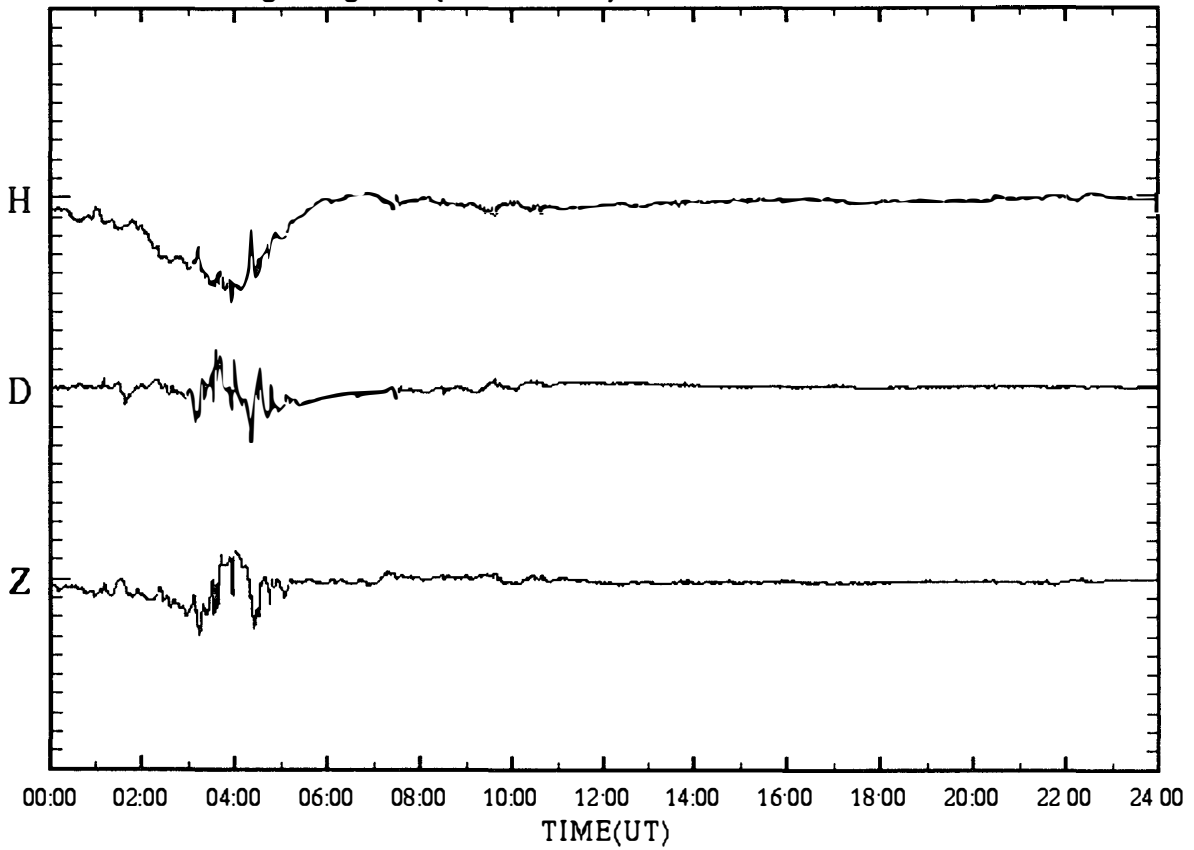

SYOWA magnetogram (100 nT/div)

24 Feb.1997 (DAY:055)

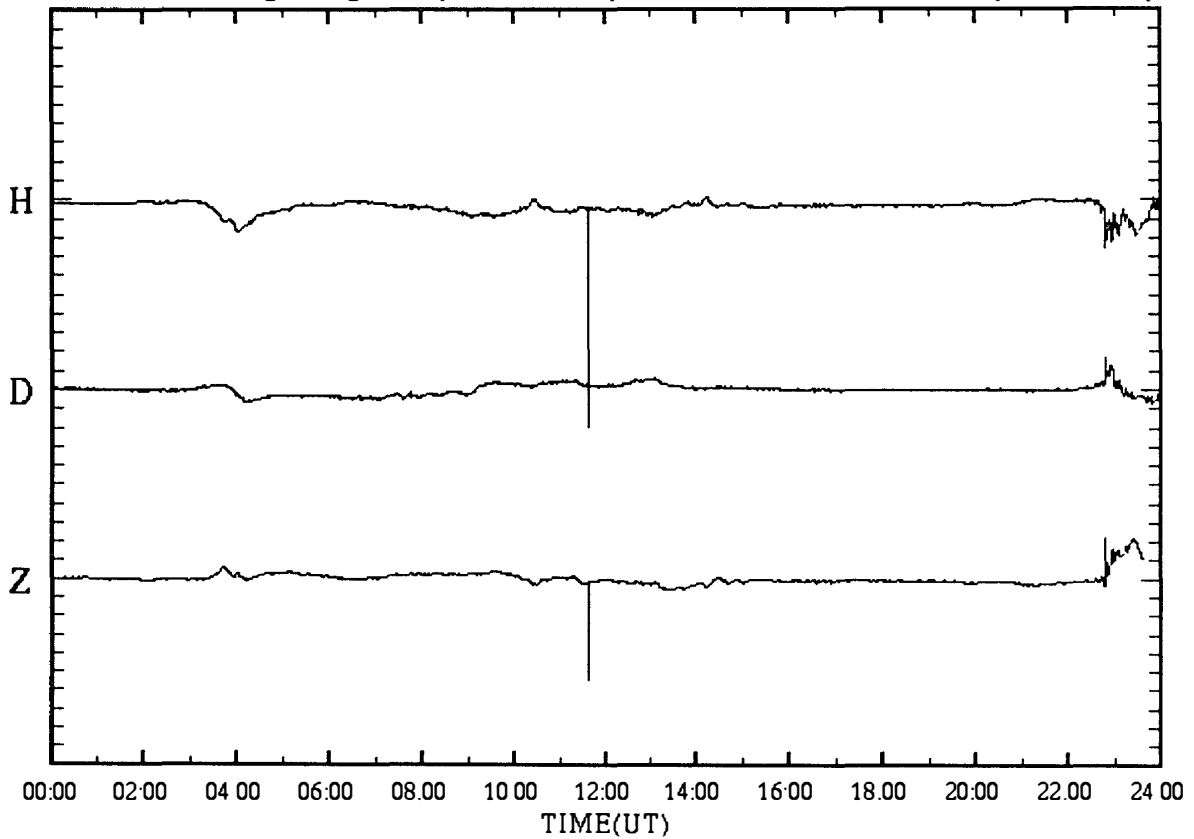

SYOWA magnetogram (100 nT/div)

25 Feb.1997 (DAY:056)

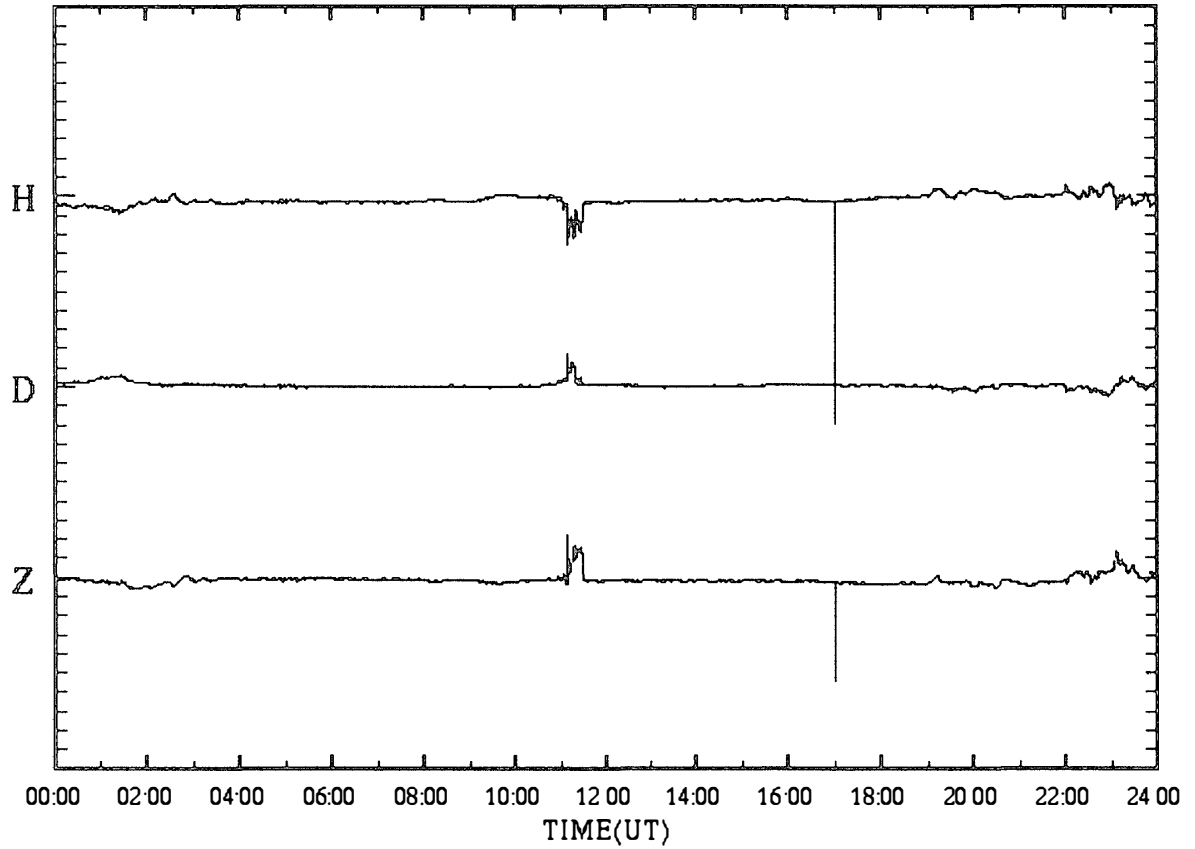

SYOWA magnetogram (100 nT/div)

26 Feb.1997 (DAY:057)

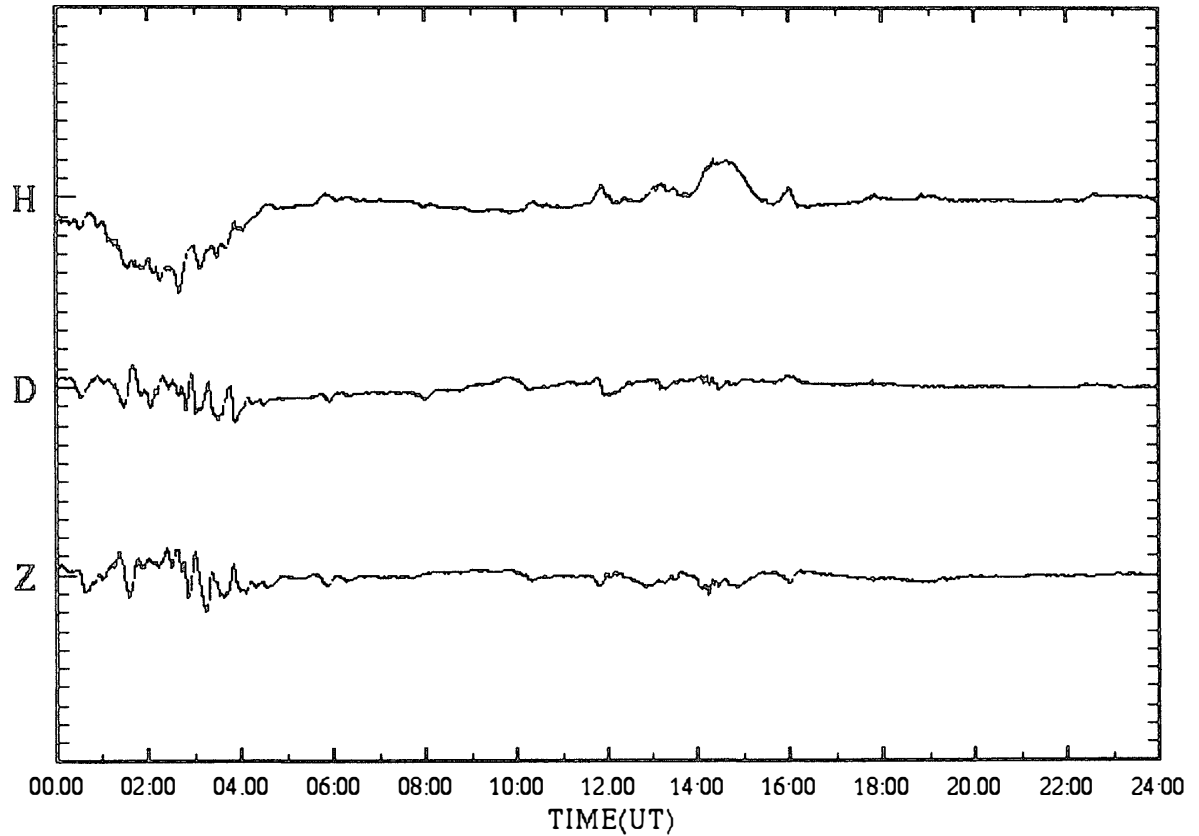

SYOWA magnetogram (100 nT/div)

27 Feb.1997 (DAY:058)

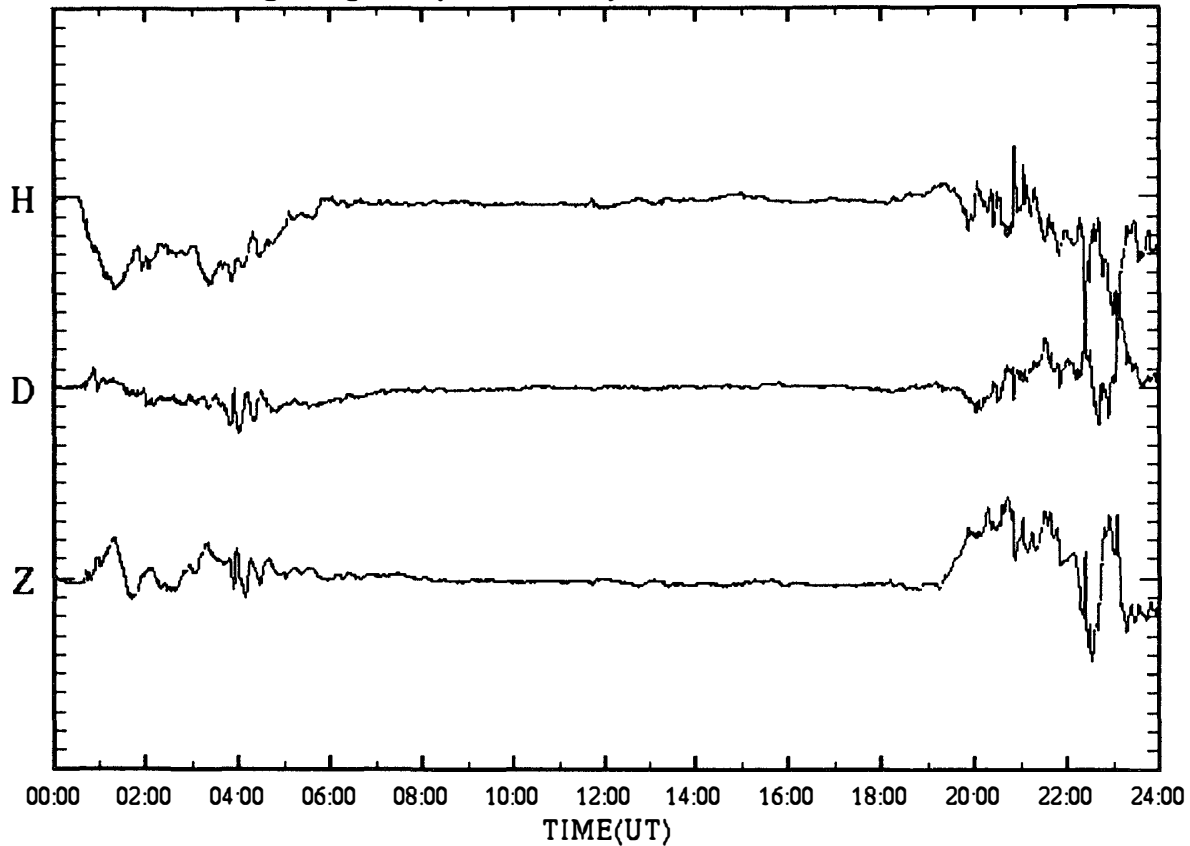

SYOWA magnetogram (100 nT/div)

28 Feb.1997 (DAY:059)

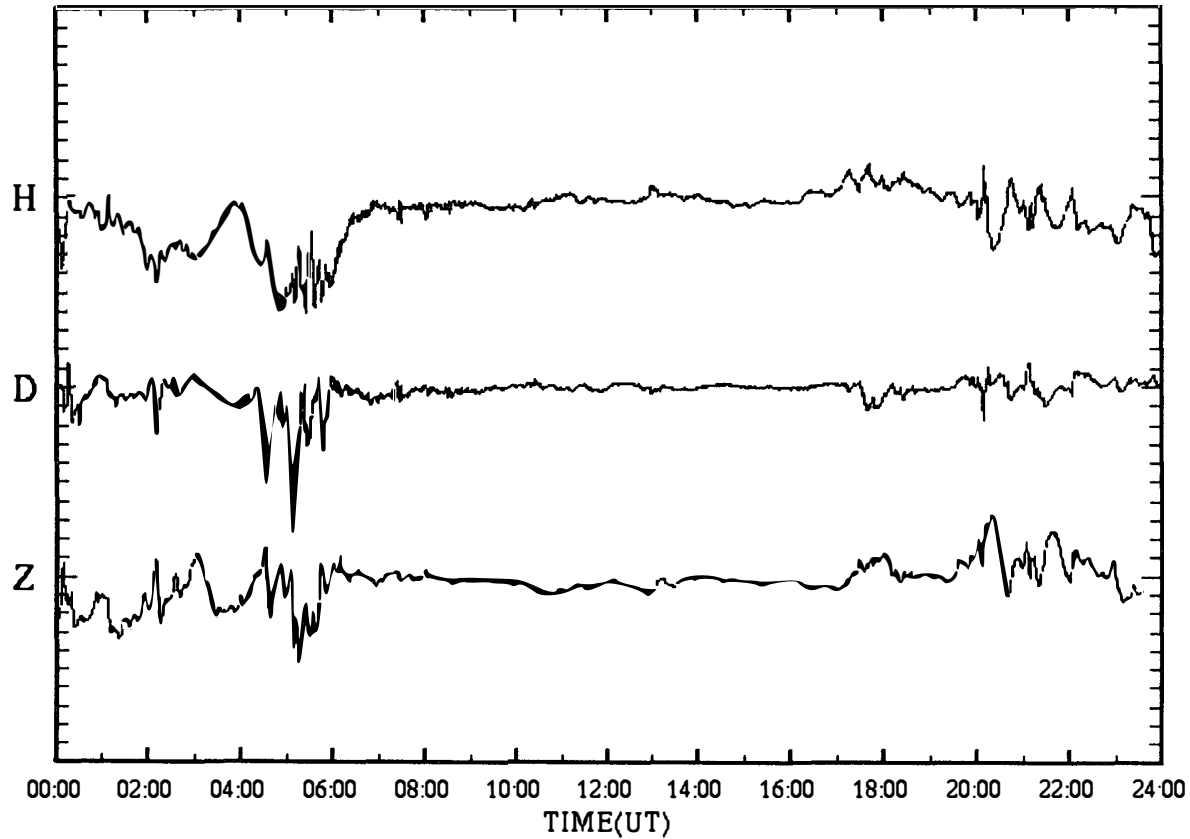

SYOWA magnetogram (100 nT/div)

01 Mar.1997 (DAY:060)

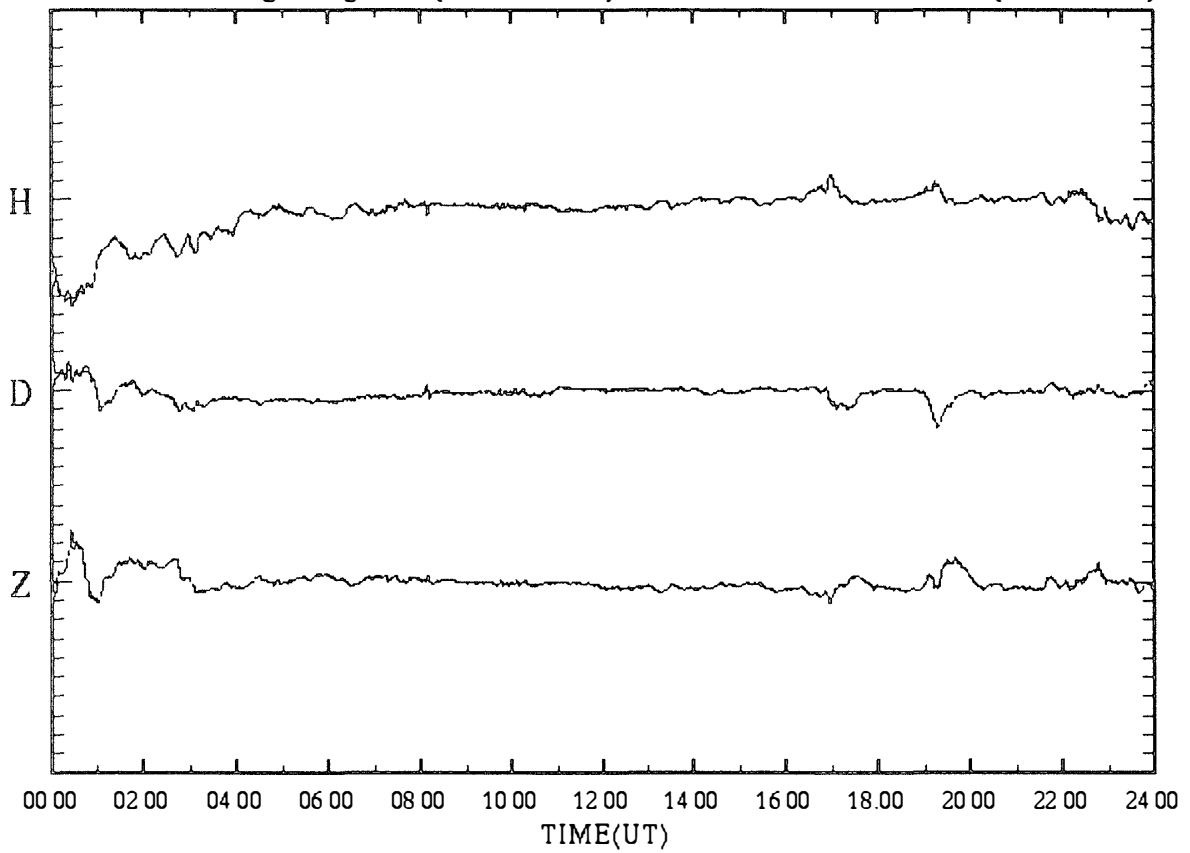

SYOWA magnetogram (100 nT/div)

02 Mar.1997 (DAY:061)

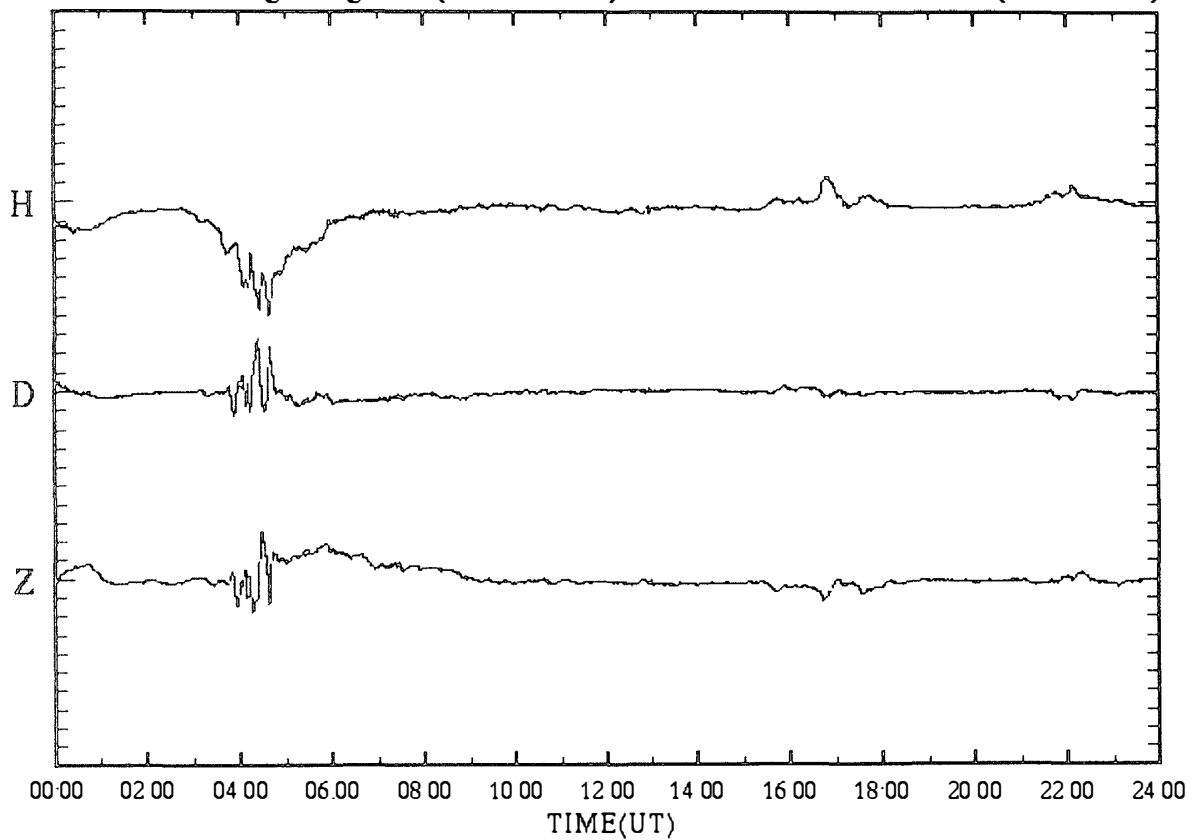

SYOWA magnetogram (100 nT/div)

03 Mar.1997 (DAY:062)

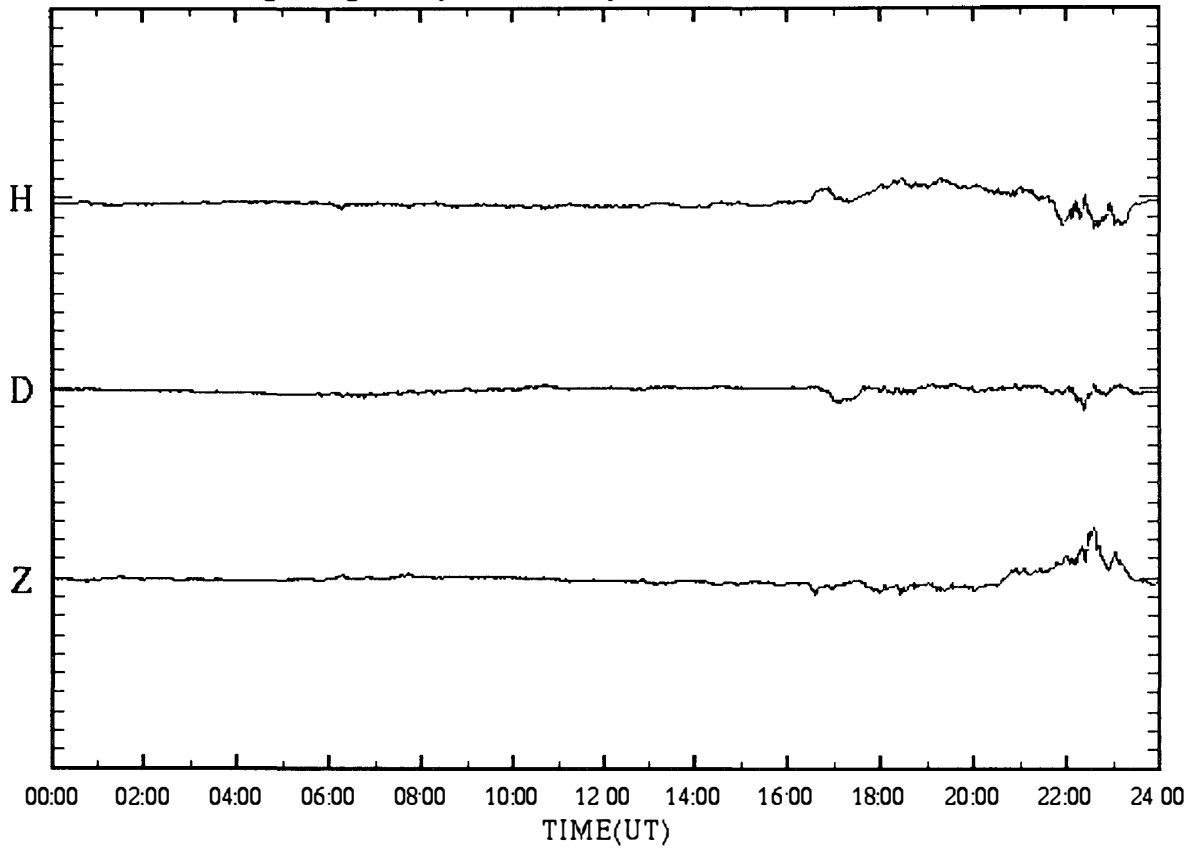

SYOWA magnetogram (100 nT/div)

04 Mar.1997 (DAY:063)

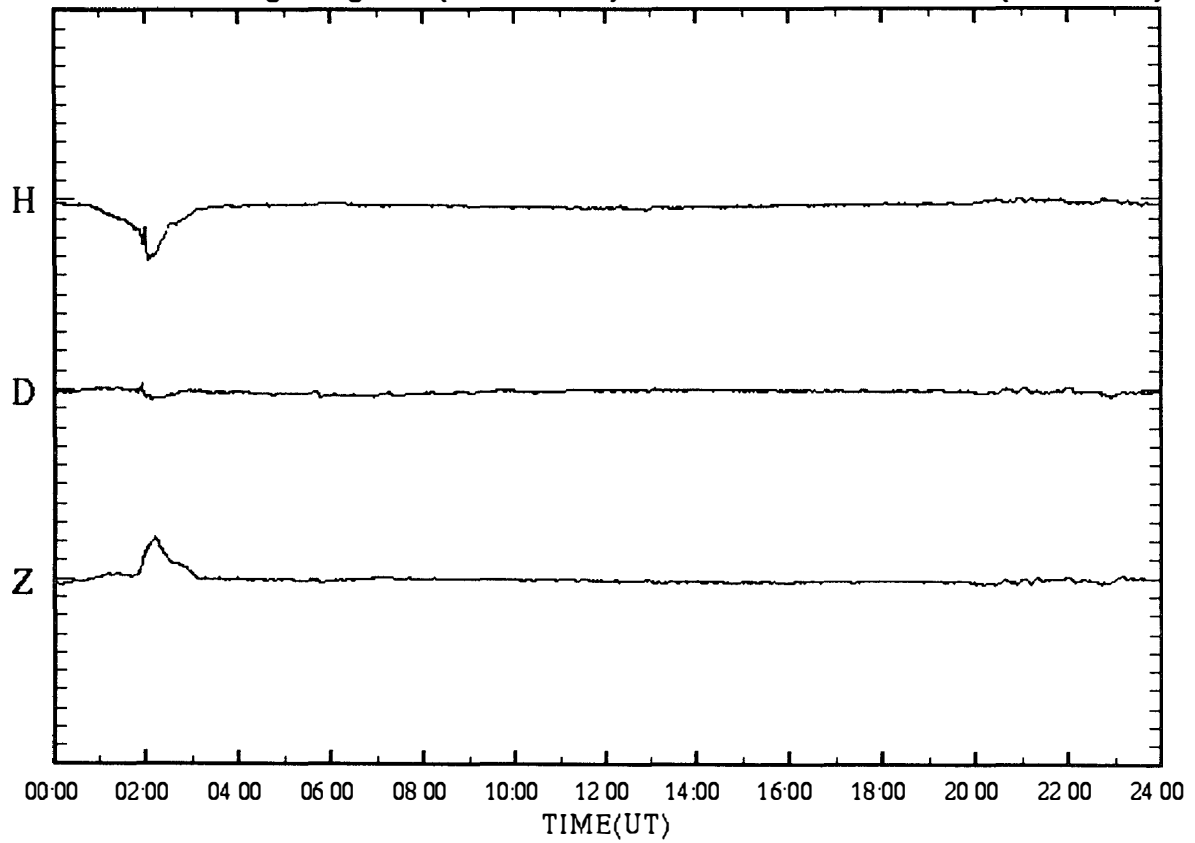

SYOWA magnetogram (100 nT/div)

05 Mar.1997 (DAY:064)

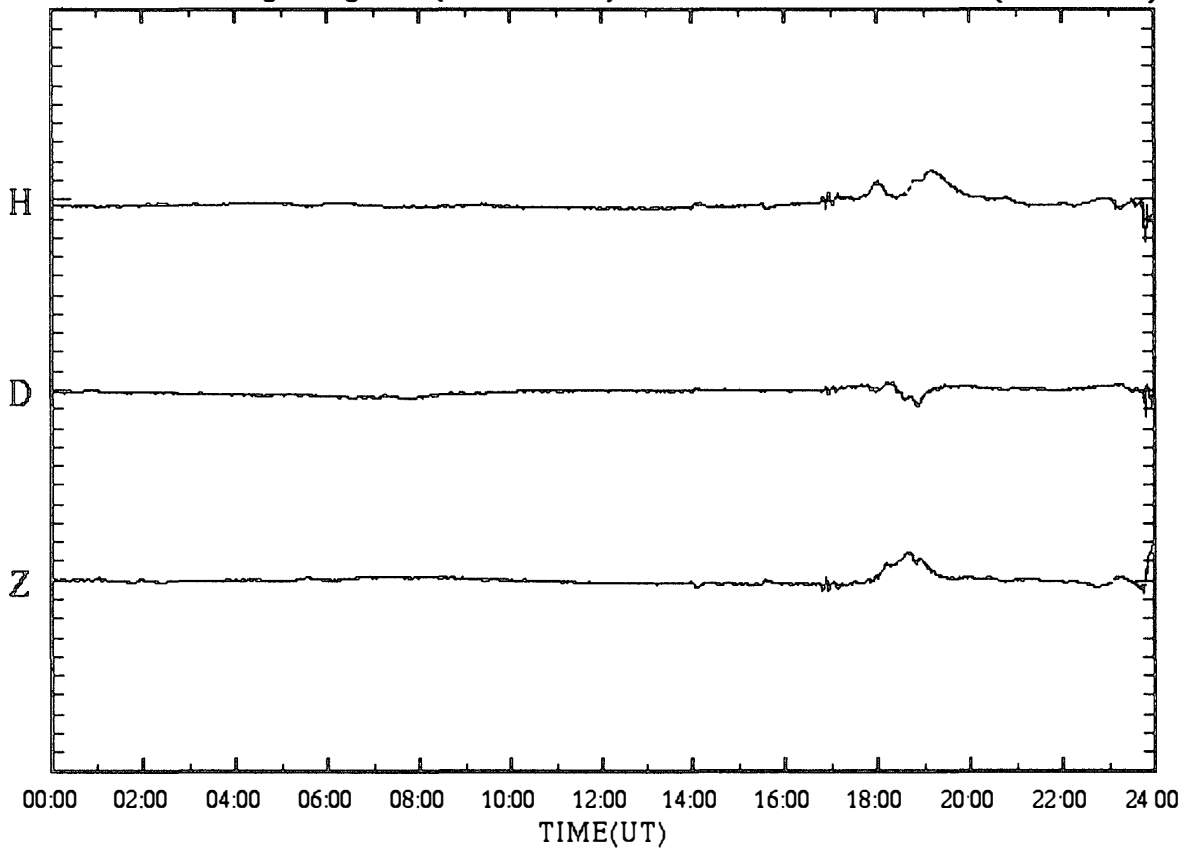

SYOWA magnetogram (100 nT/div)

06 Mar.1997 (DAY:065)

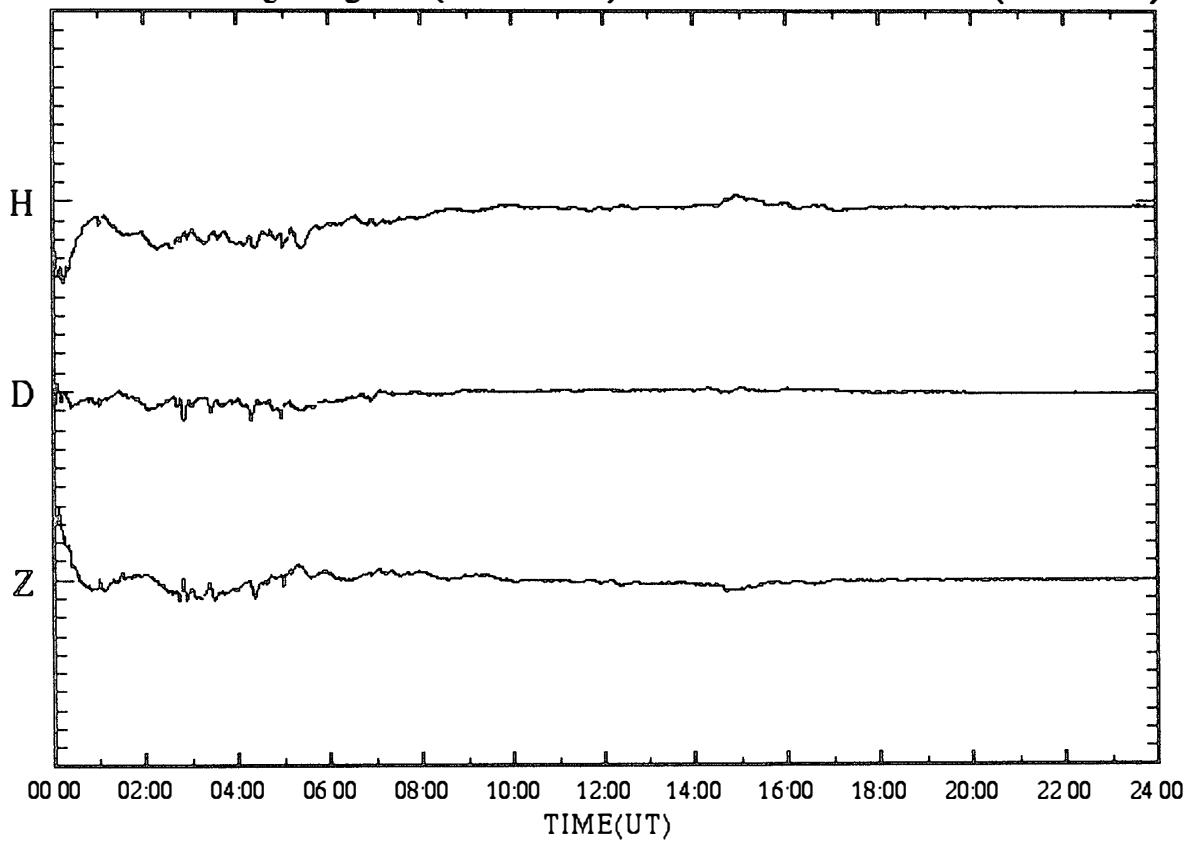

SYOWA magnetogram (100 nT/div)

07 Mar.1997 (DAY:066)

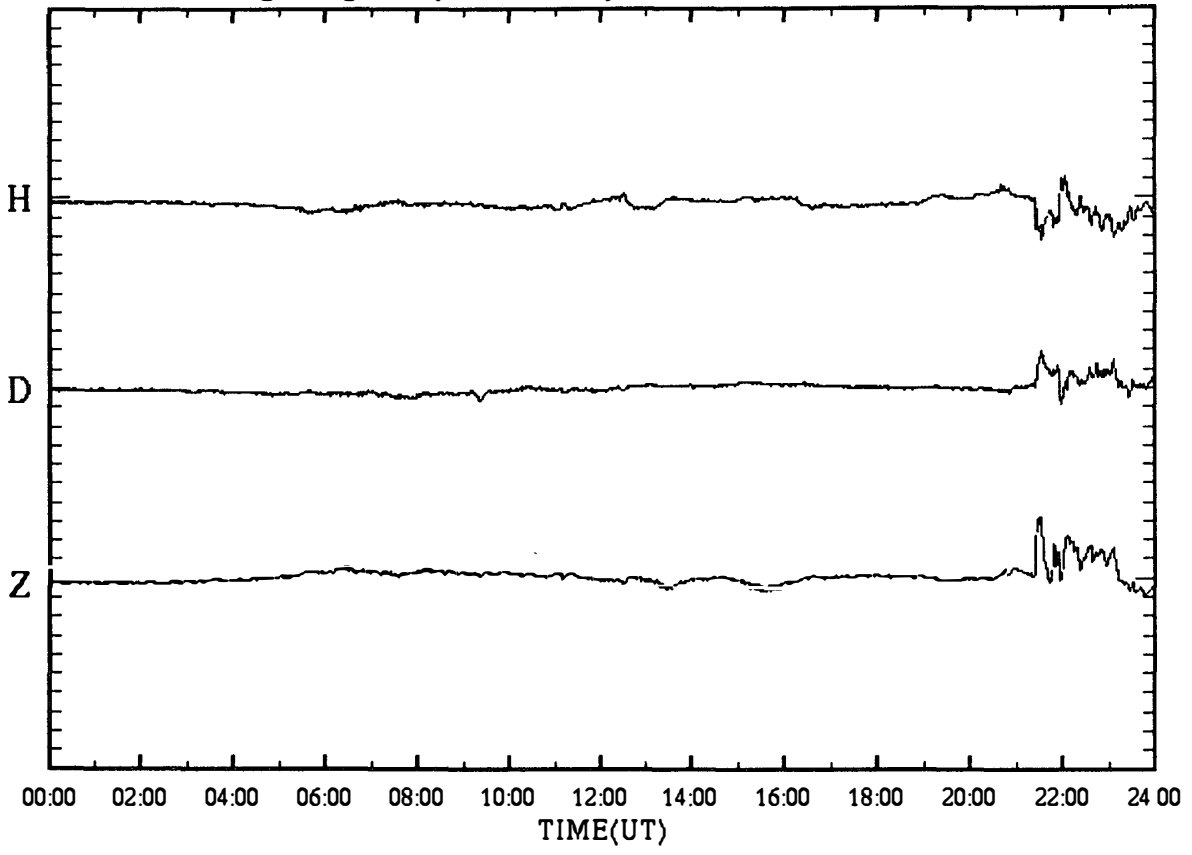

SYOWA magnetogram (100 nT/div)

08 Mar.1997 (DAY:067)

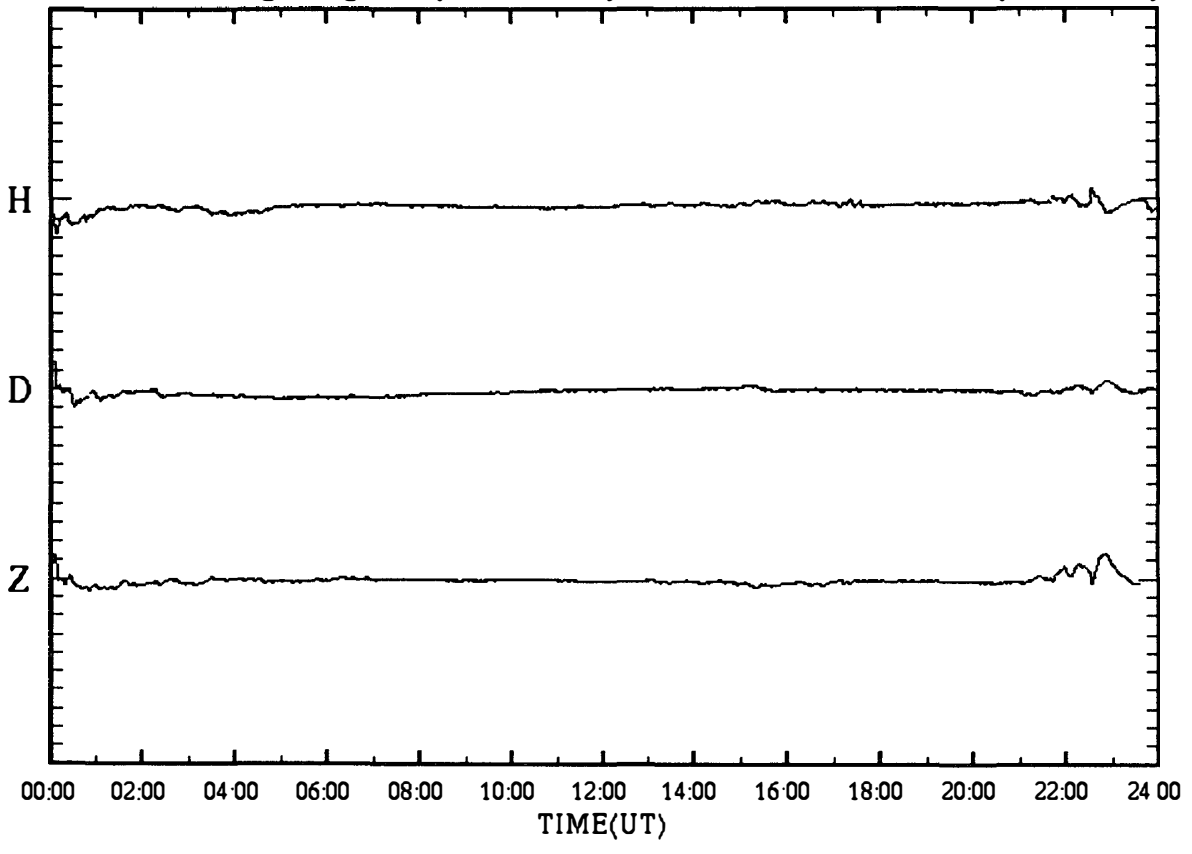

SYOWA magnetogram (100 nT/div)

09 Mar.1997 (DAY:068)

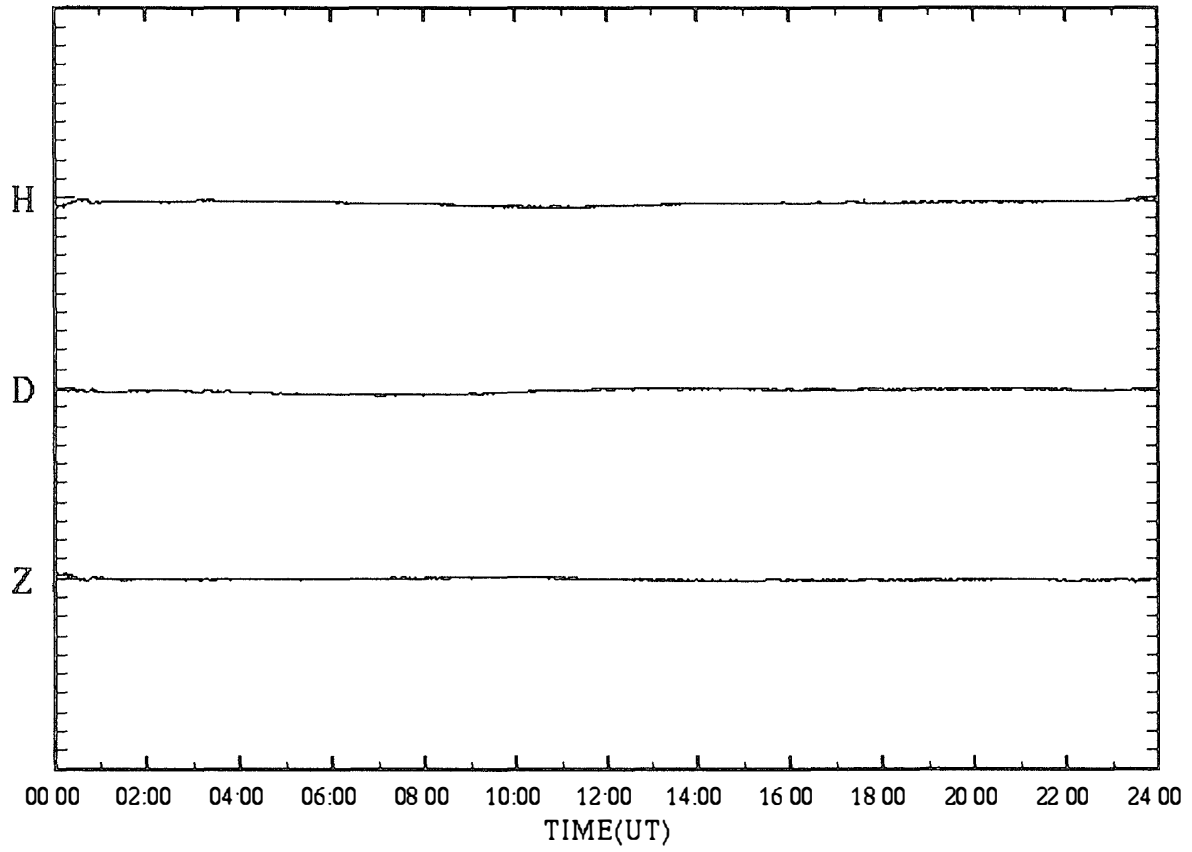

SYOWA magnetogram (100 nT/div)

10 Mar.1997 (DAY:069)

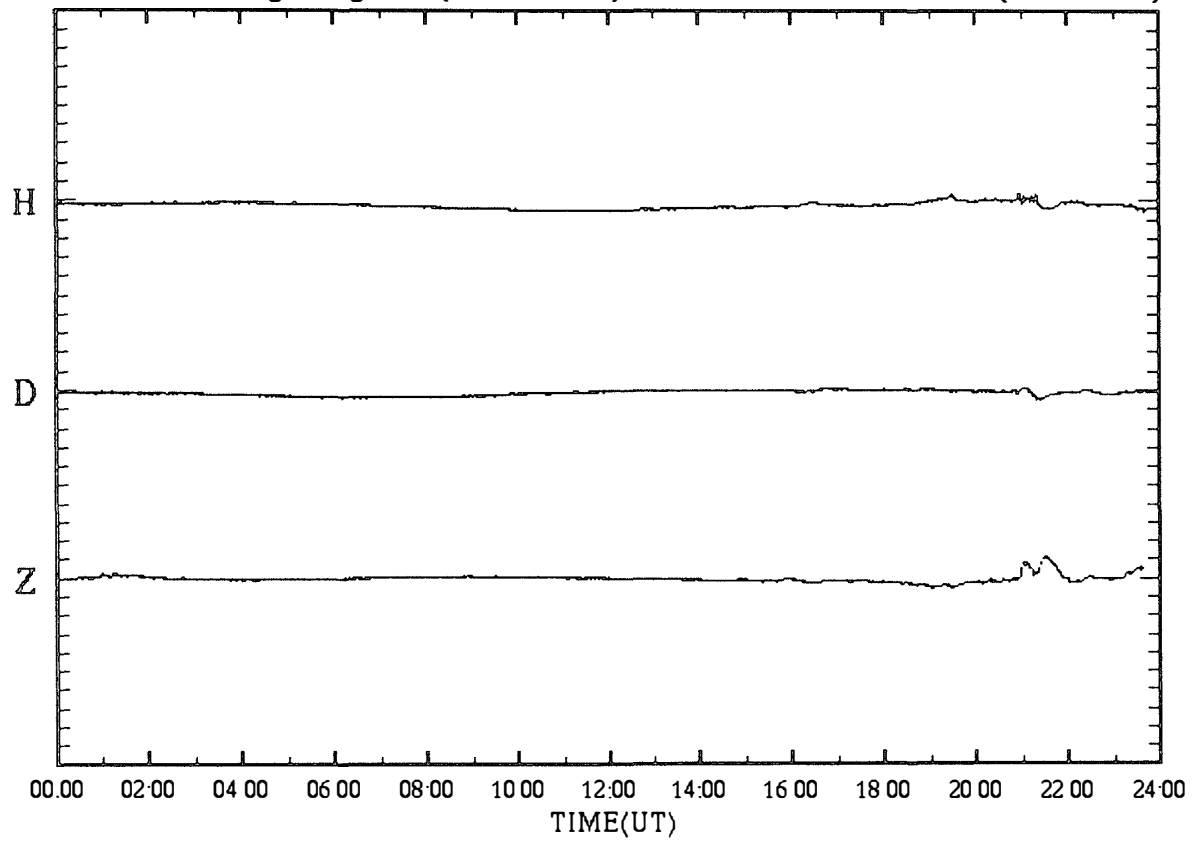



SYOWA magnetogram (100 nT/div)

11 Mar.1997 (DAY:070)

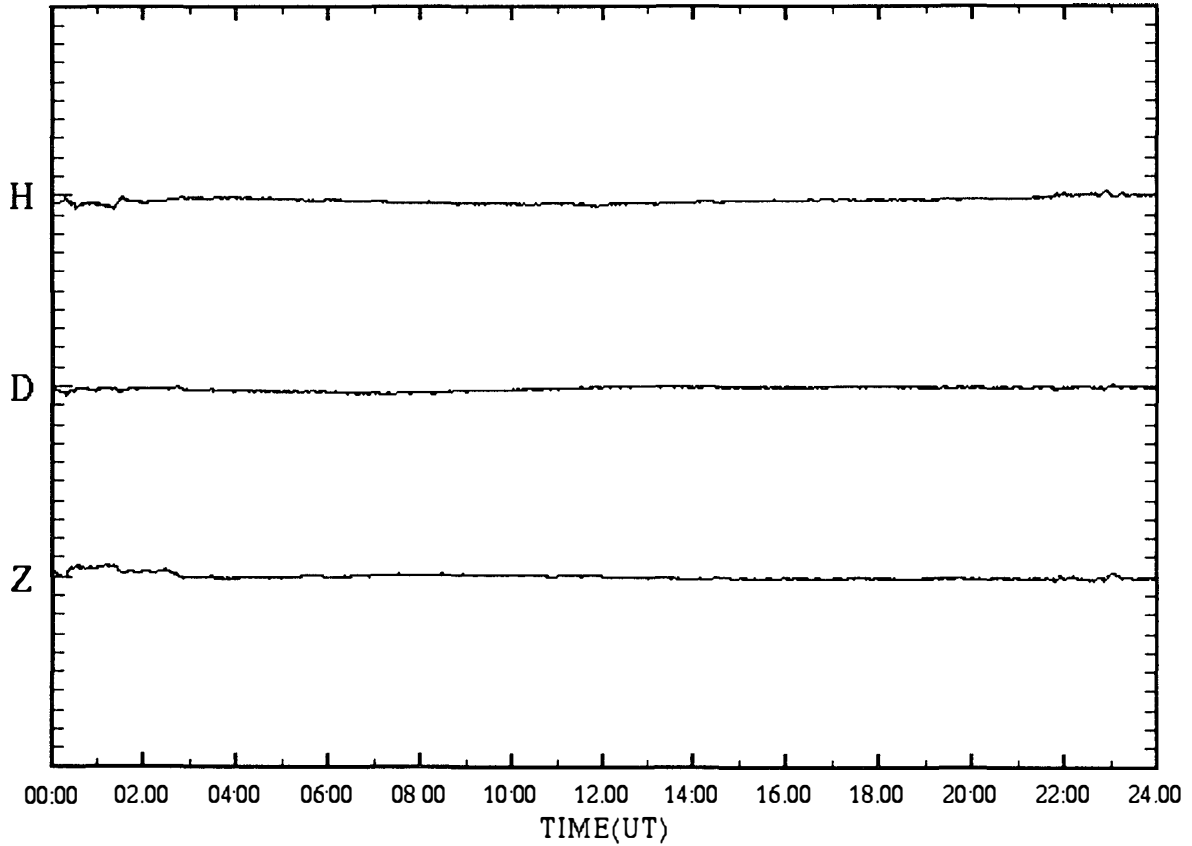

SYOWA magnetogram (100 nT/div)

12 Mar.1997 (DAY:071)

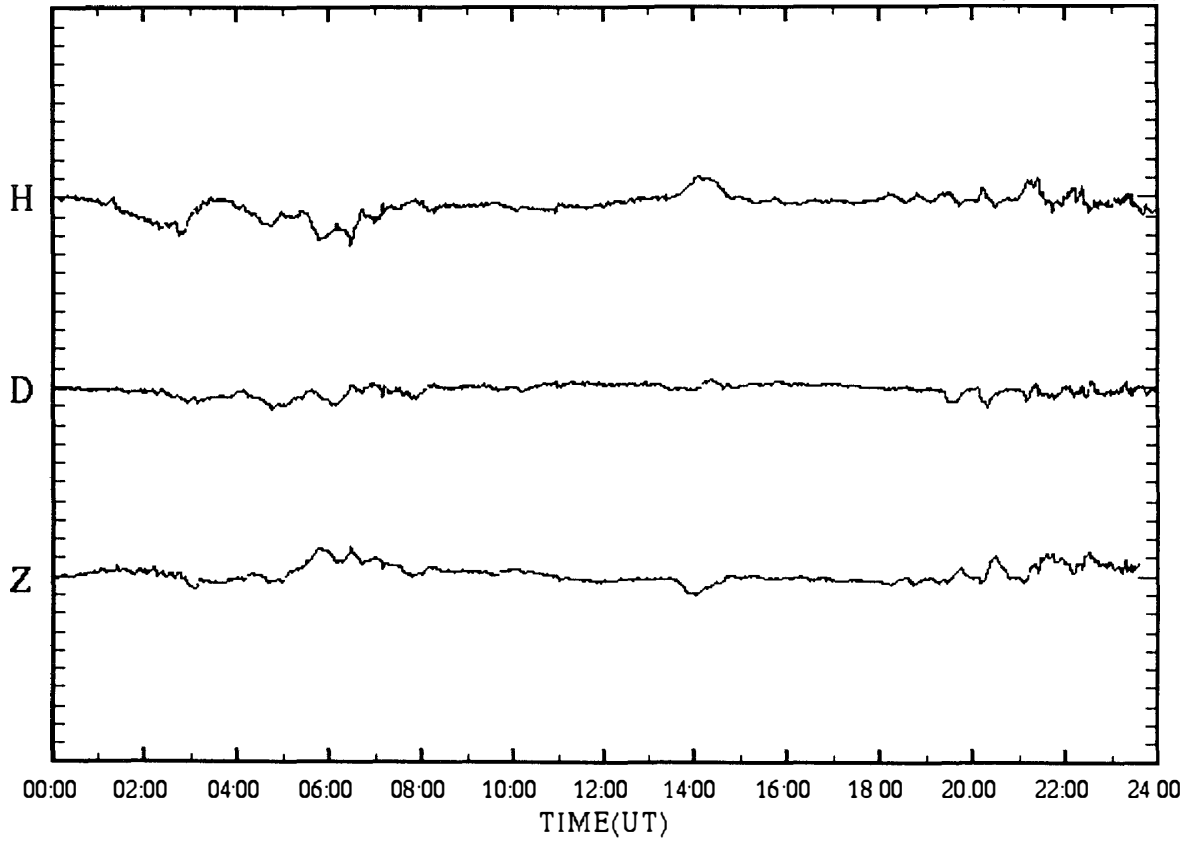

SYOWA magnetogram (100 nT/div)

13 Mar.1997 (DAY:072)

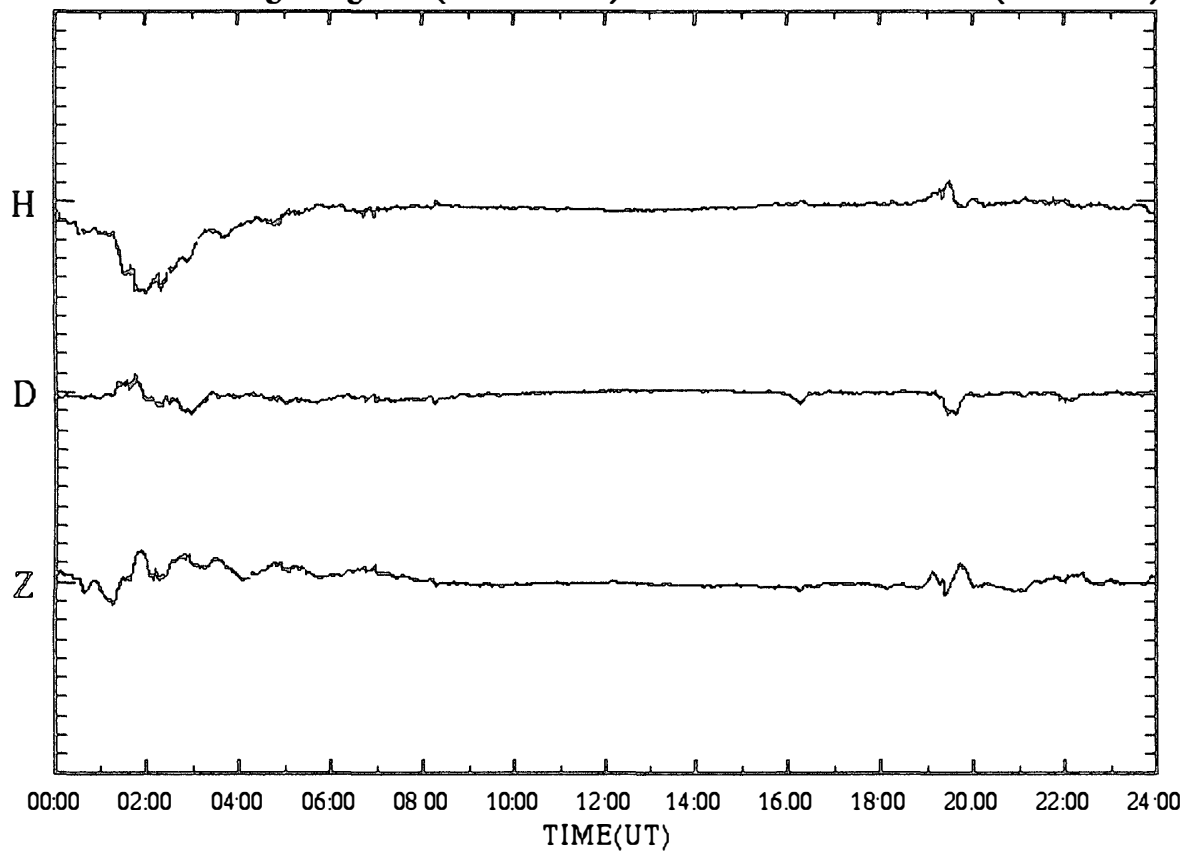

SYOWA magnetogram (100 nT/div)

14 Mar.1997 (DAY:073)

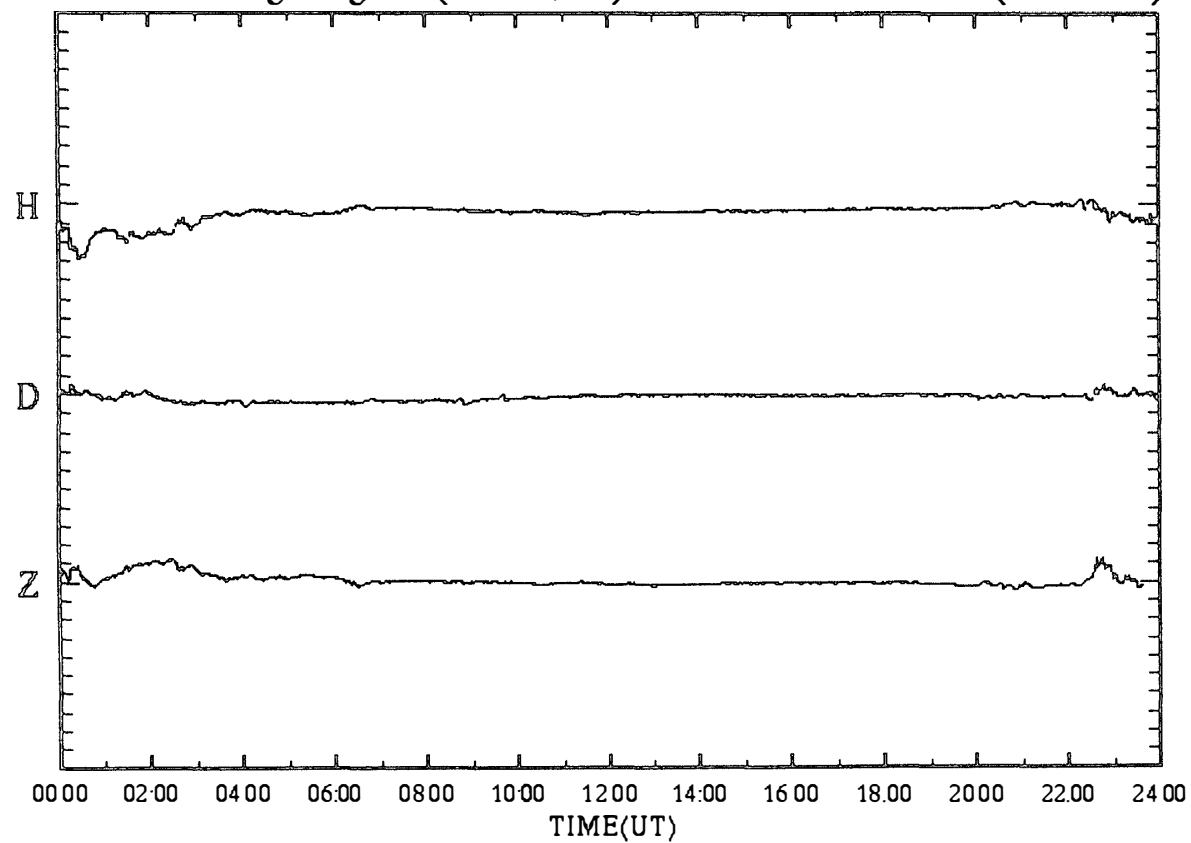

SYOWA magnetogram (100 nT/div)

15 Mar.1997 (DAY:074)

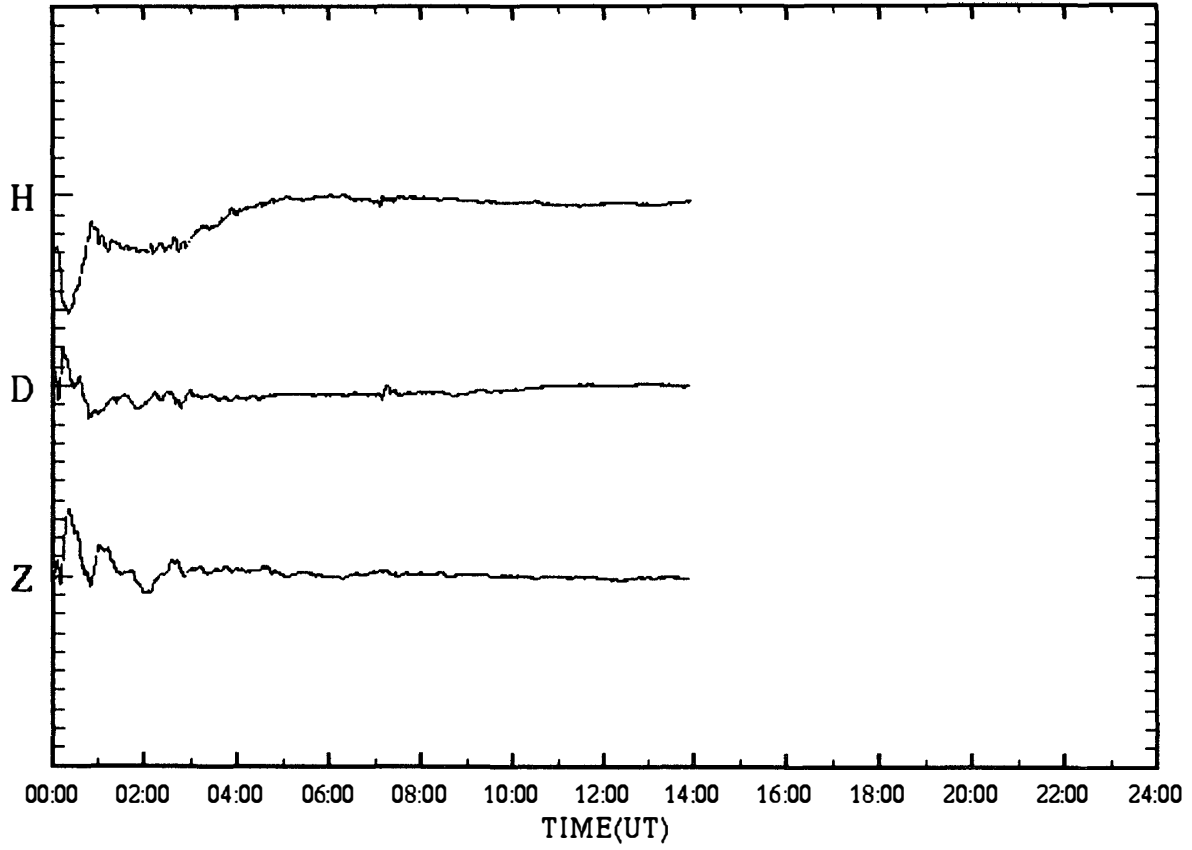

SYOWA magnetogram (100 nT/div)

16 Mar.1997 (DAY:075)

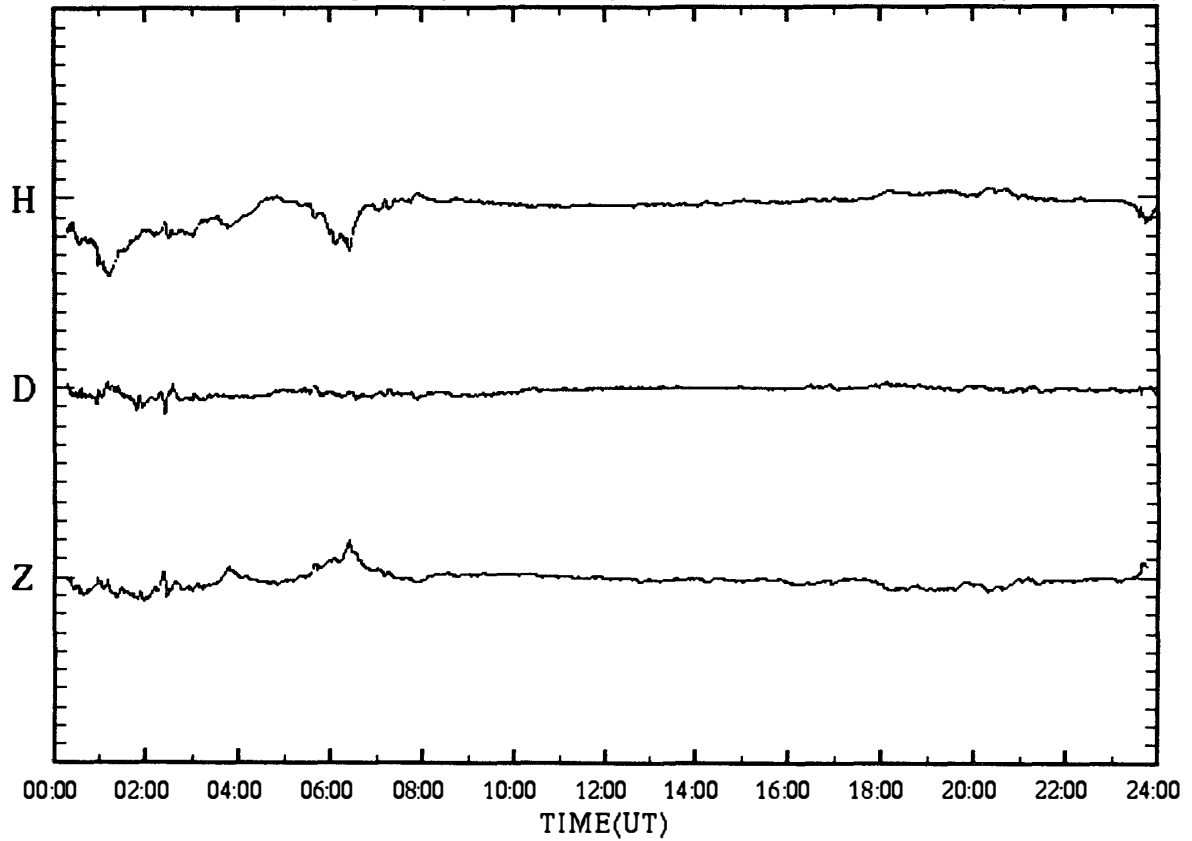

SYOWA magnetogram (100 nT/div)

17 Mar.1997 (DAY:076)

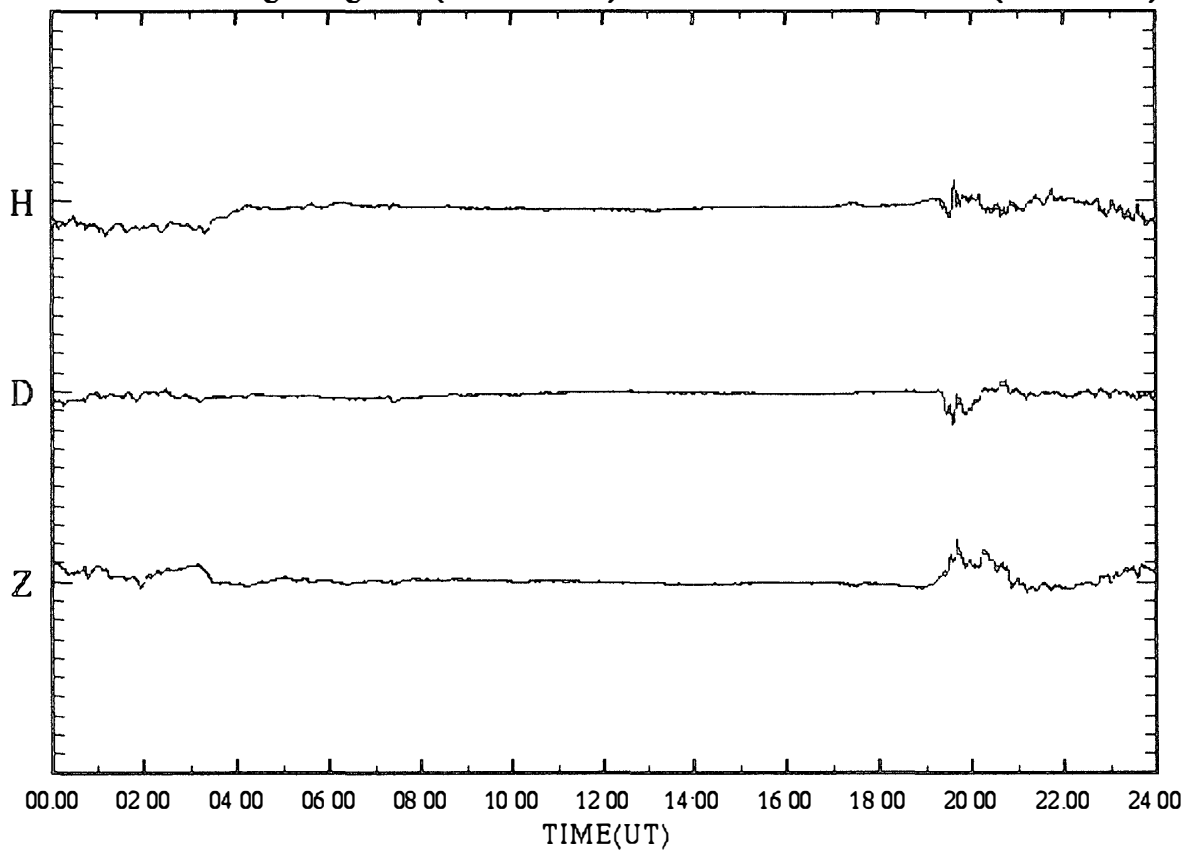

SYOWA magnetogram (100 nT/div)

18 Mar.1997 (DAY:077)

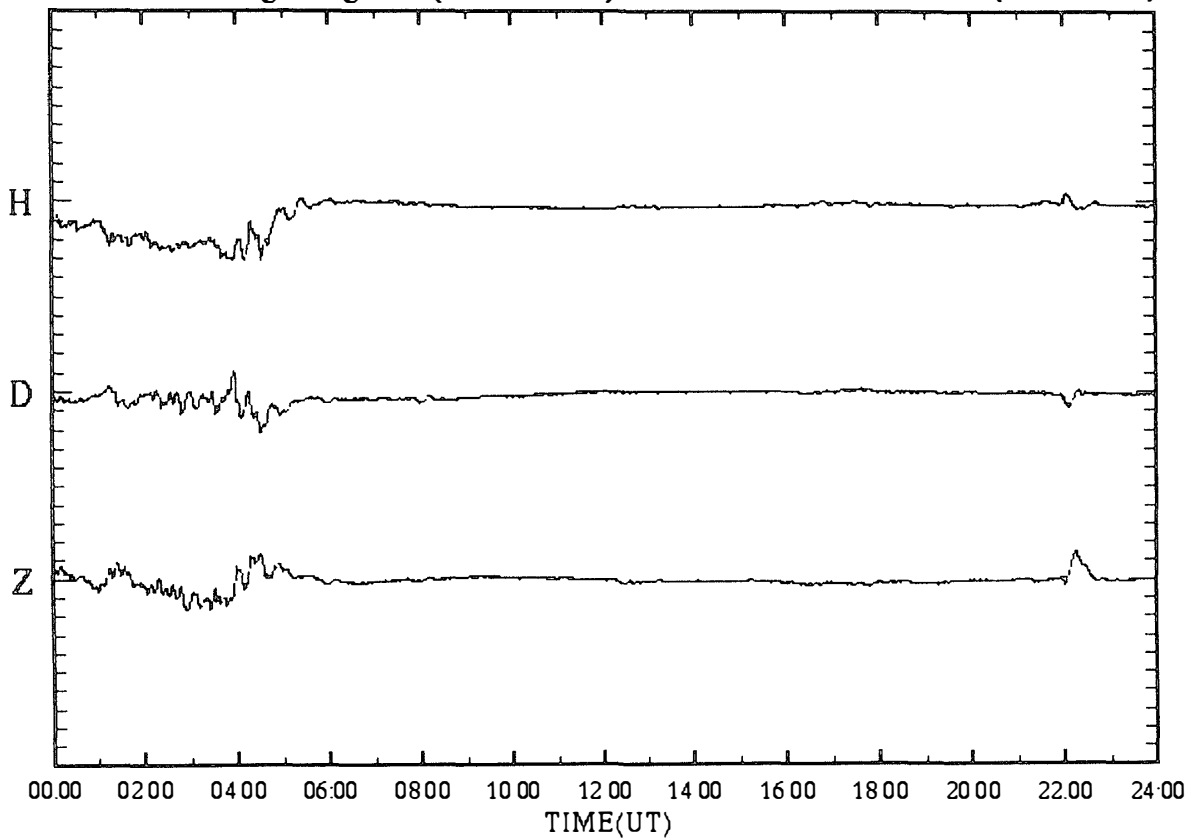

SYOWA magnetogram (100 nT/div)

19 Mar.1997 (DAY:078)

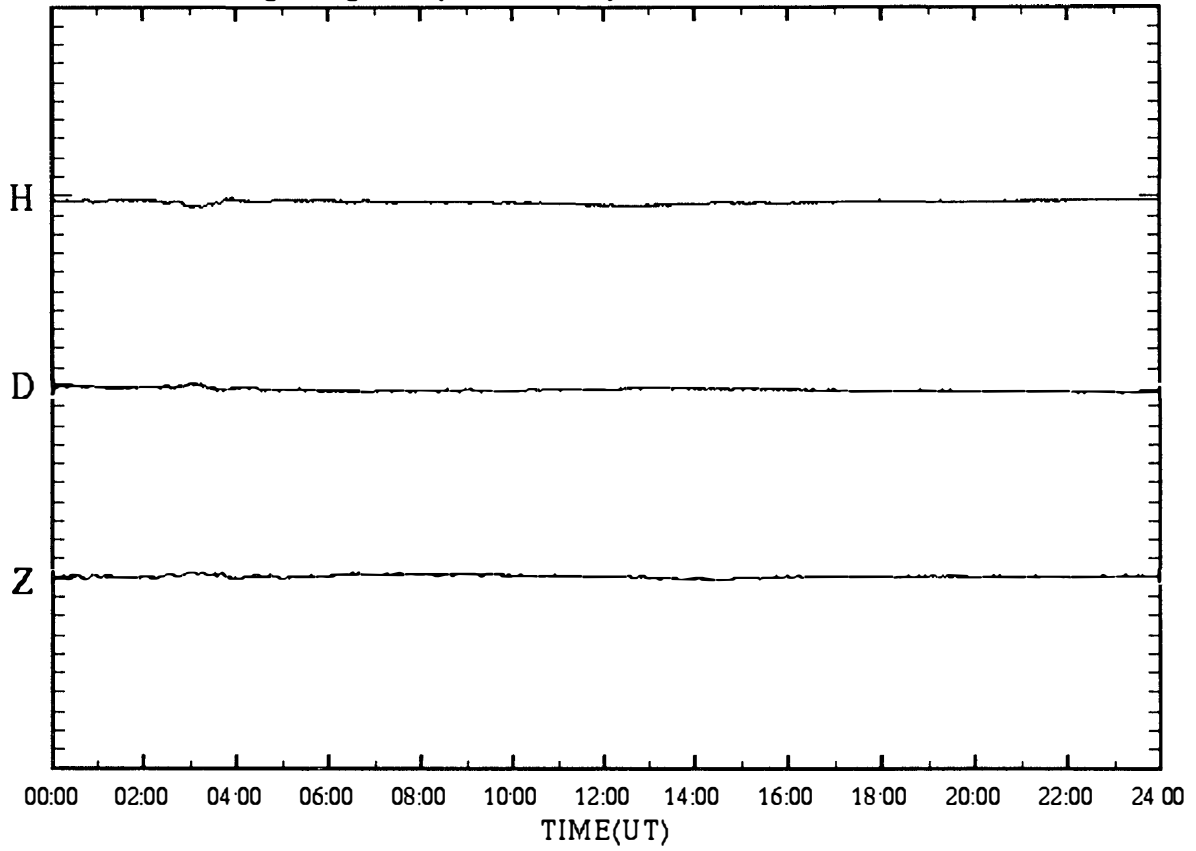

SYOWA magnetogram (100 nT/div)

20 Mar.1997 (DAY:079)

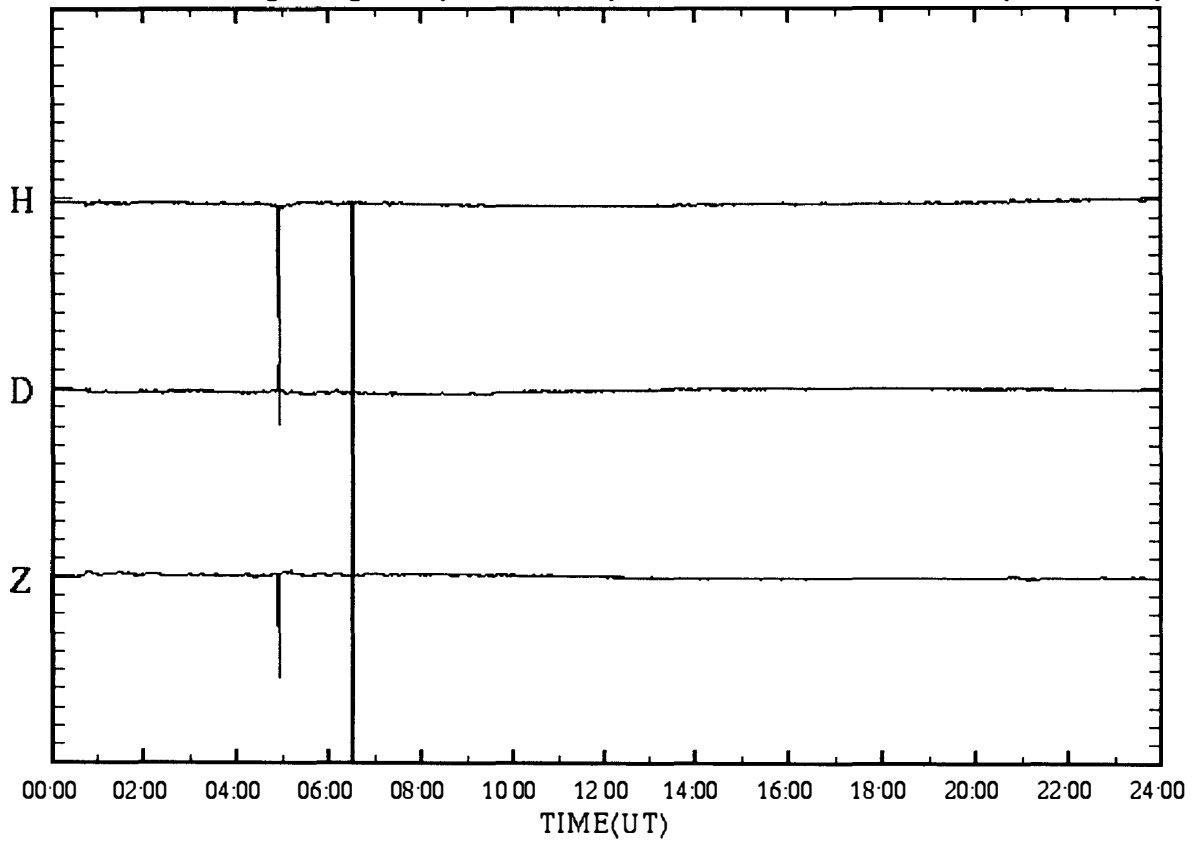

SYOWA magnetogram (100 nT/div)

21 Mar.1997 (DAY:080)

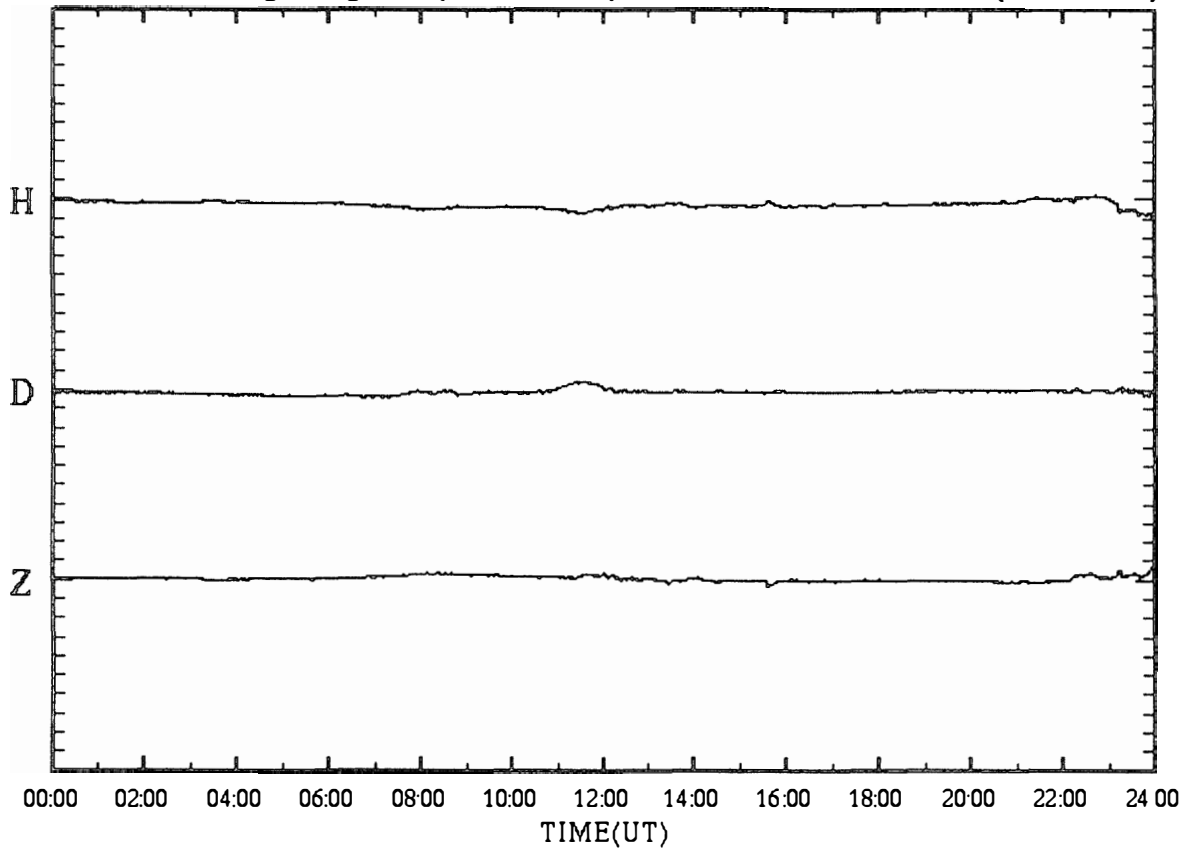

SYOWA magnetogram (100 nT/div)

22 Mar.1997 (DAY:081)

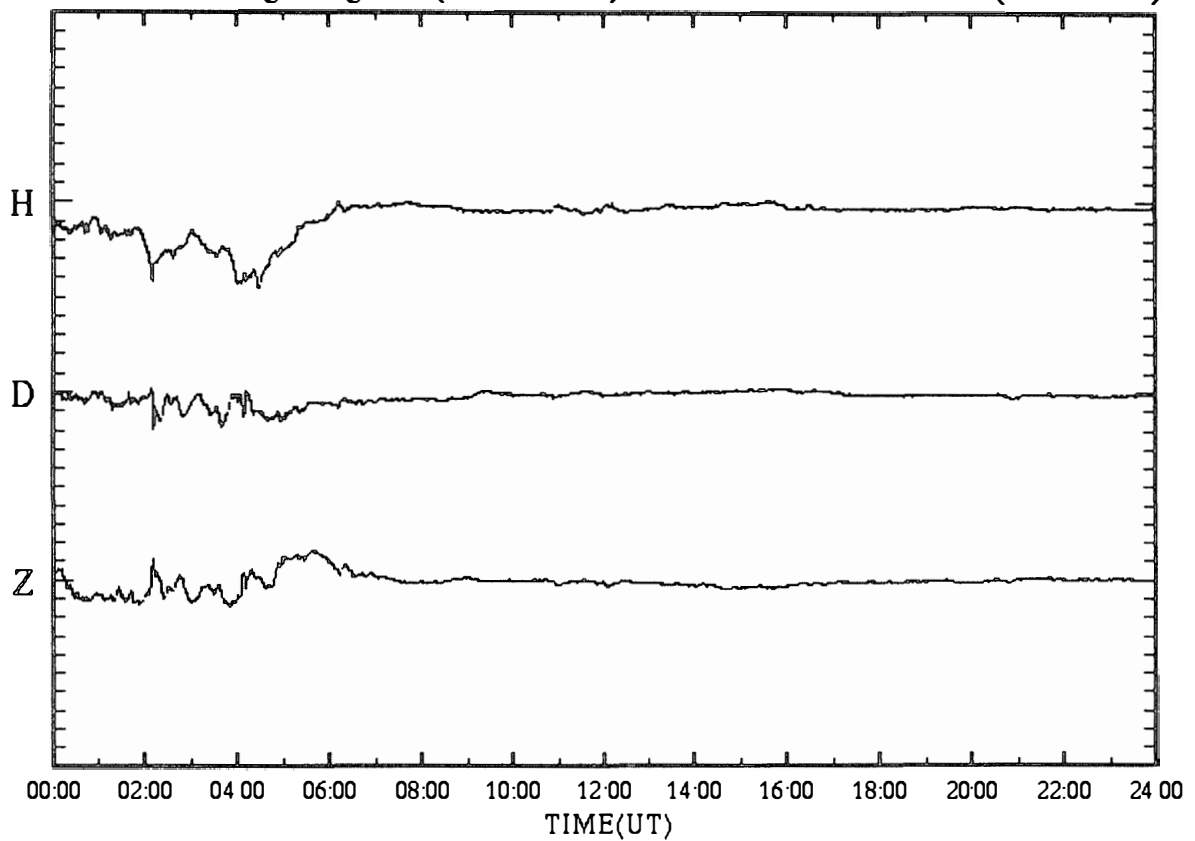

SYOWA magnetogram (100 nT/div)

23 Mar.1997 (DAY:082)

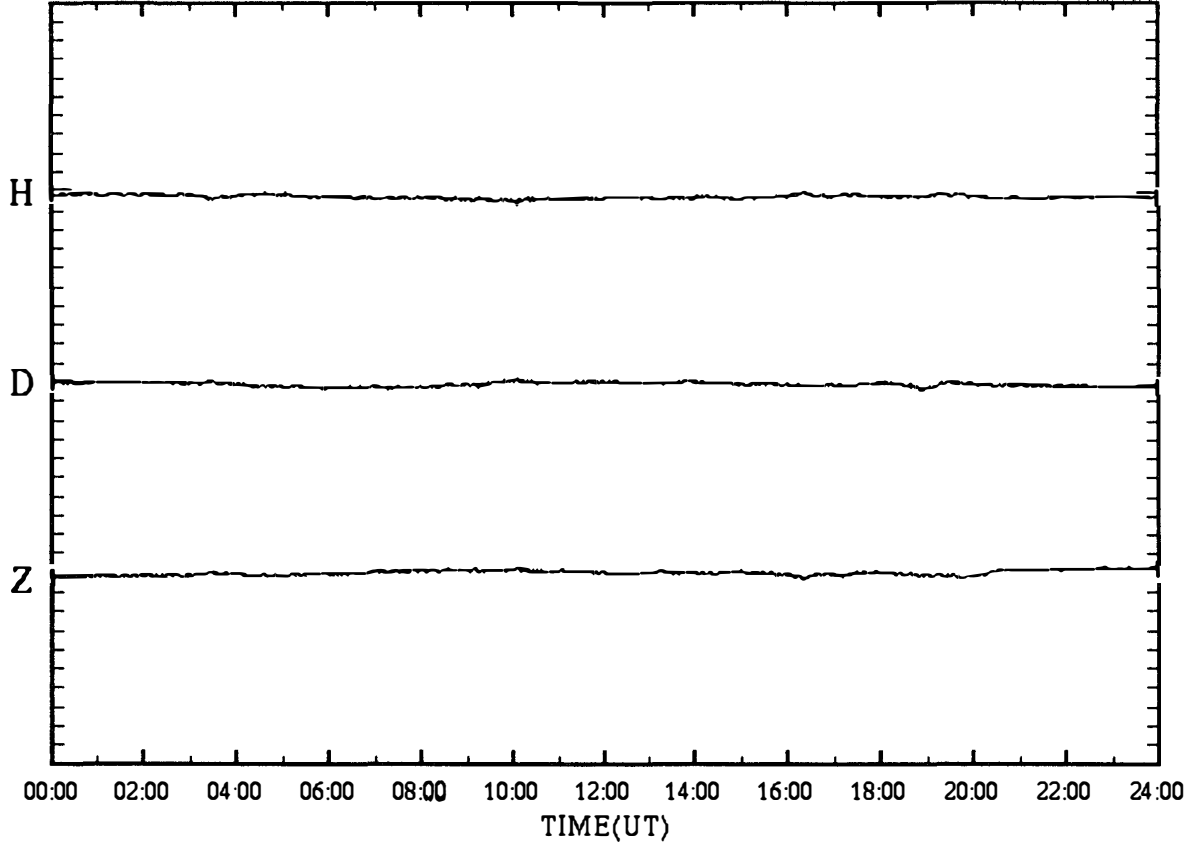

SYOWA magnetogram (100 nT/div)

24 Mar.1997 (DAY:083)

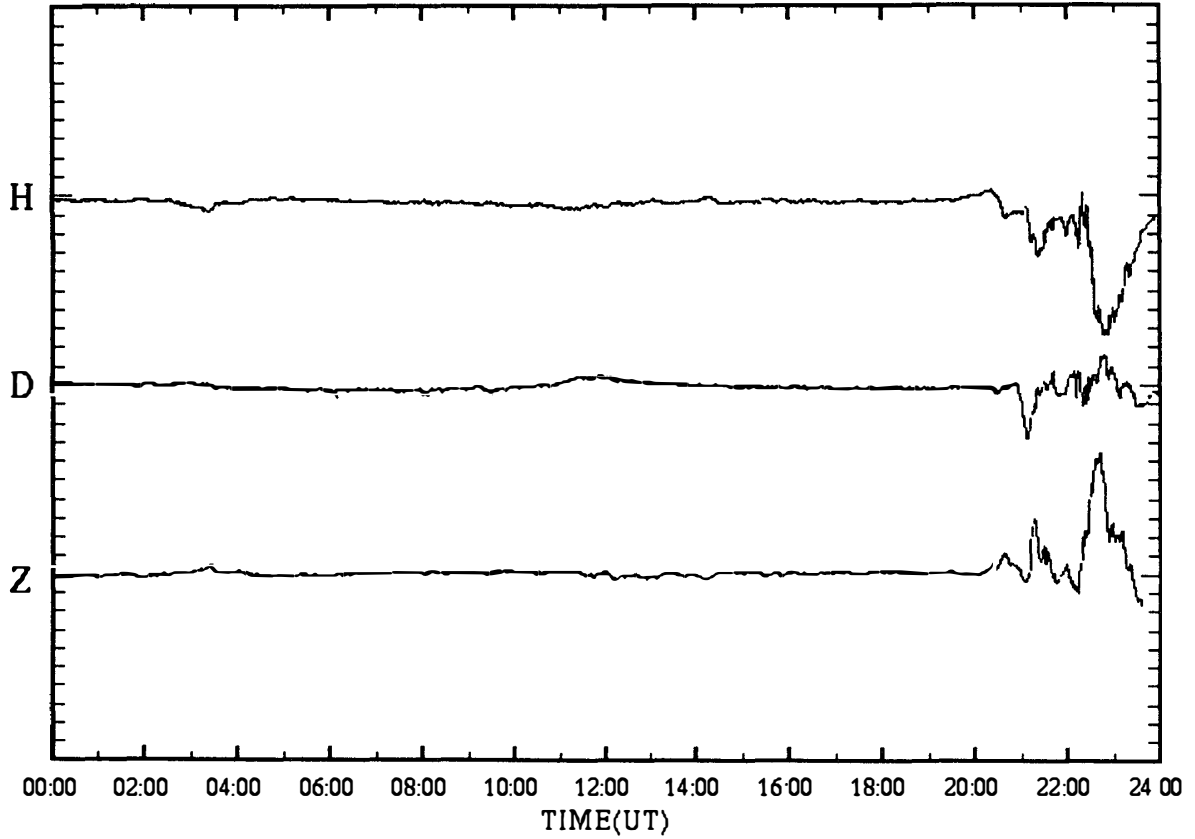

SYOWA magnetogram (100 nT/div)

25 Mar.1997 (DAY:084)

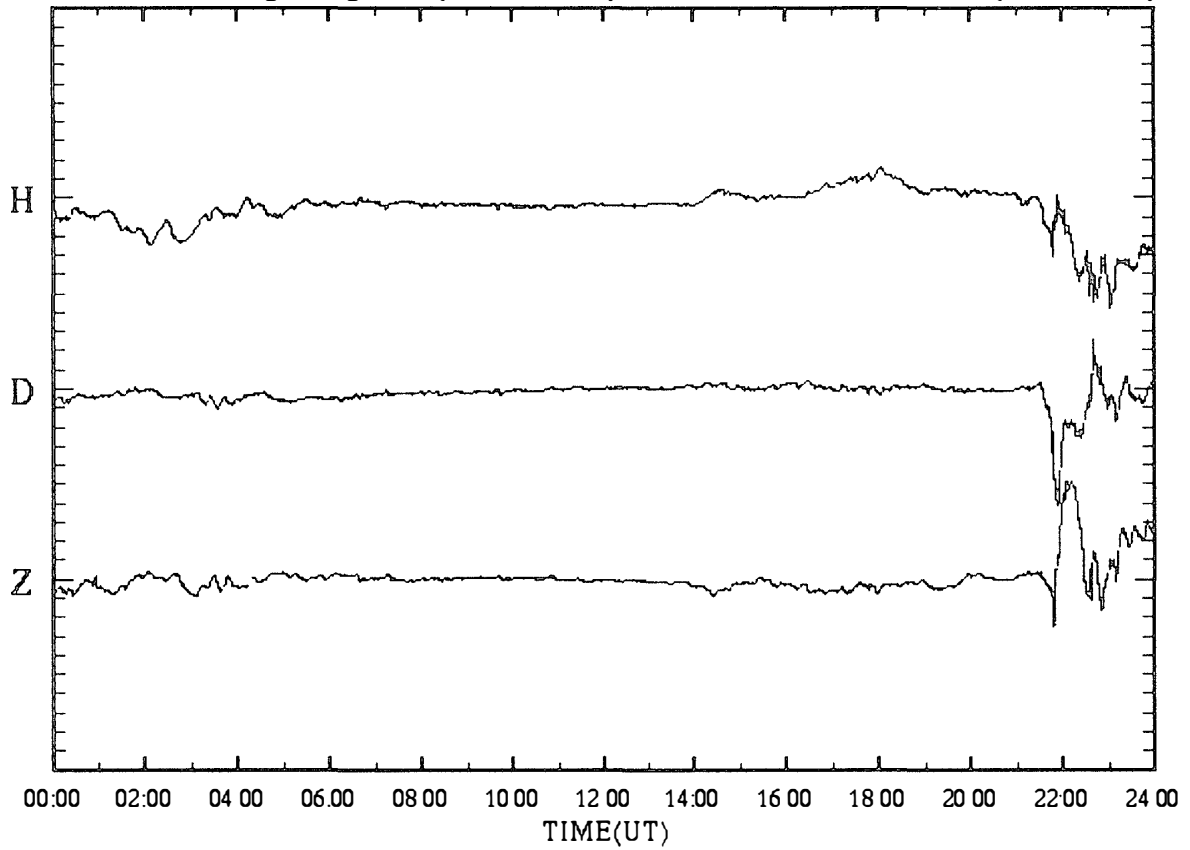

SYOWA magnetogram (100 nT/div)

26 Mar.1997 (DAY:085)

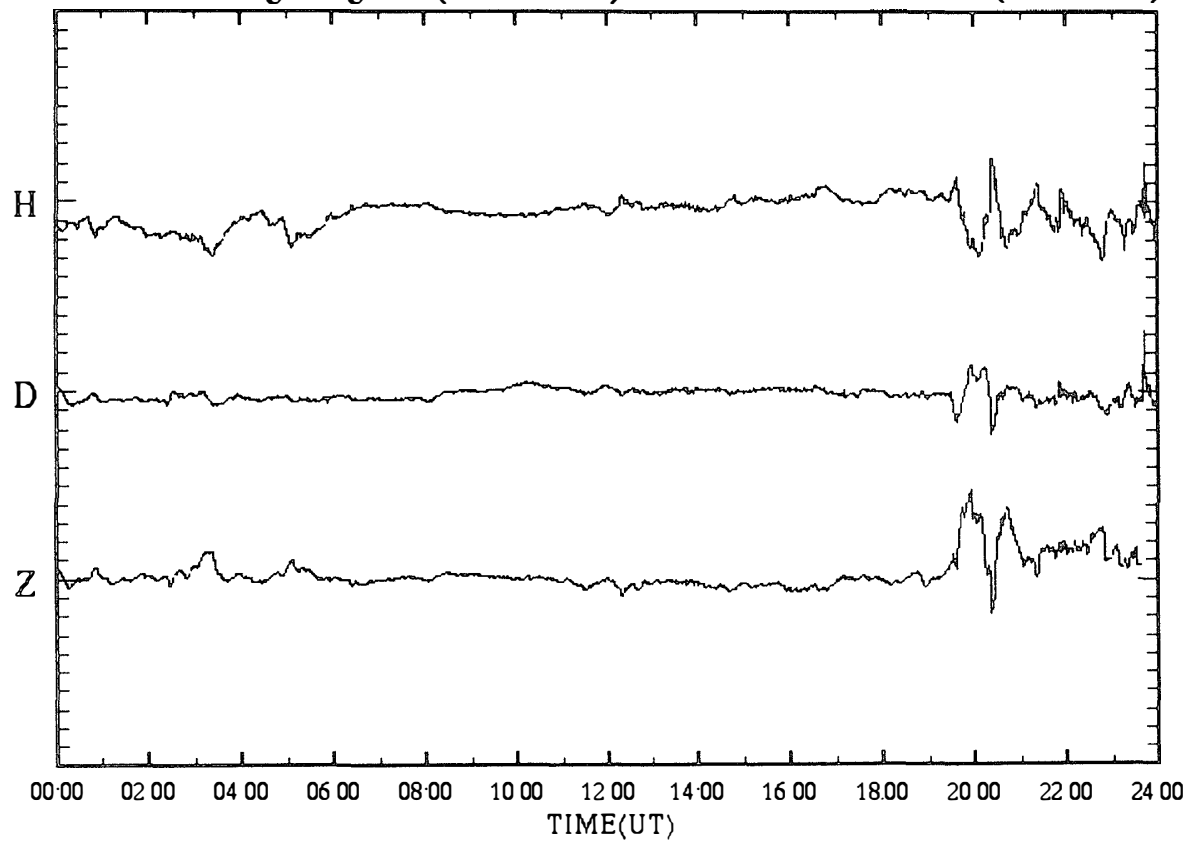



SYOWA magnetogram (100 nT/div)

27 Mar.1997 (DAY:086)

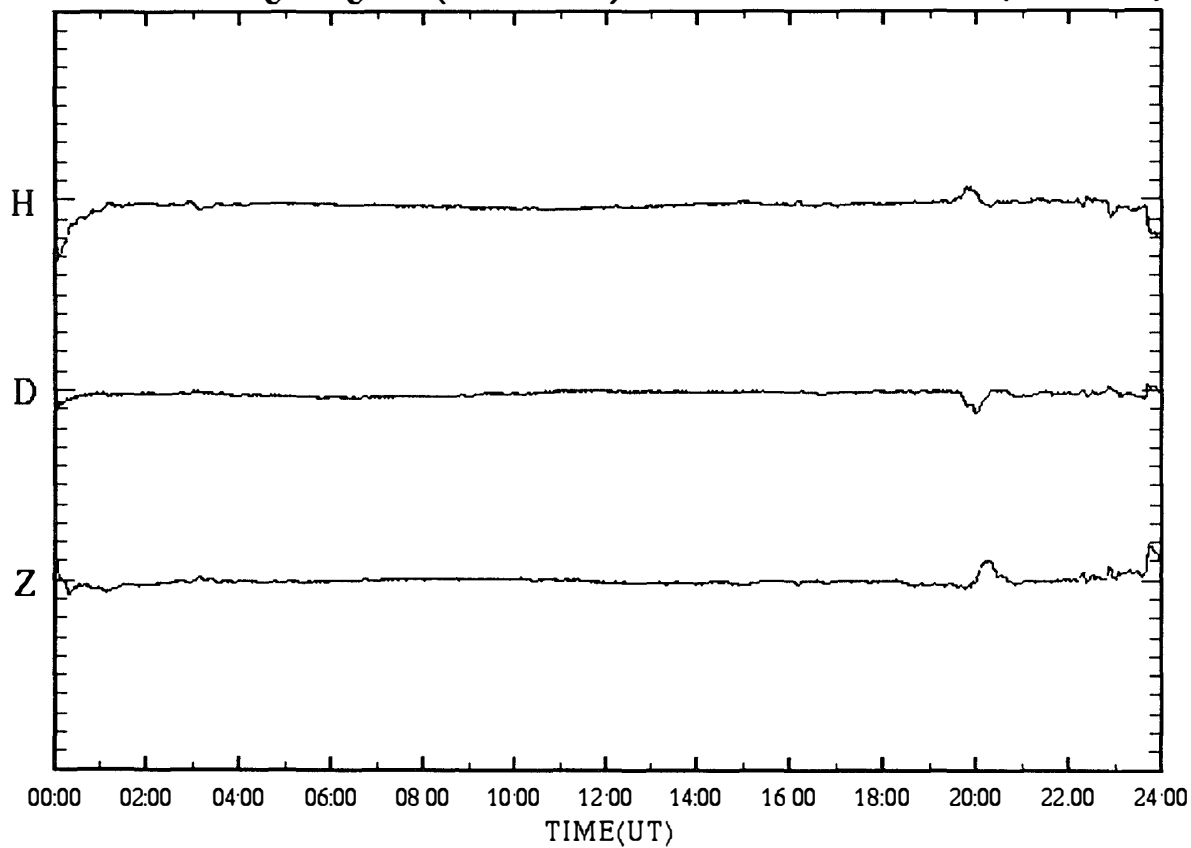

SYOWA magnetogram (100 nT/div)

28 Mar.1997 (DAY:087)

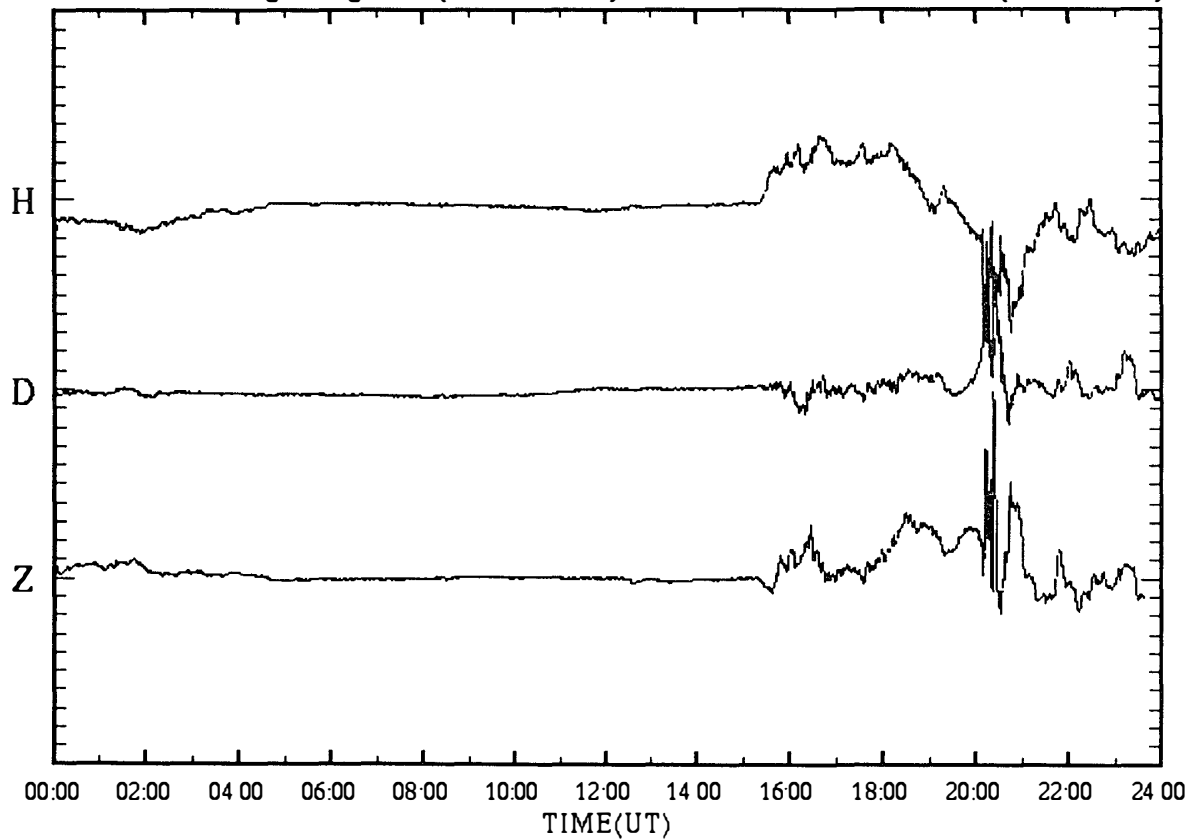

SYOWA magnetogram (100 nT/div)

29 Mar.1997 (DAY:088)

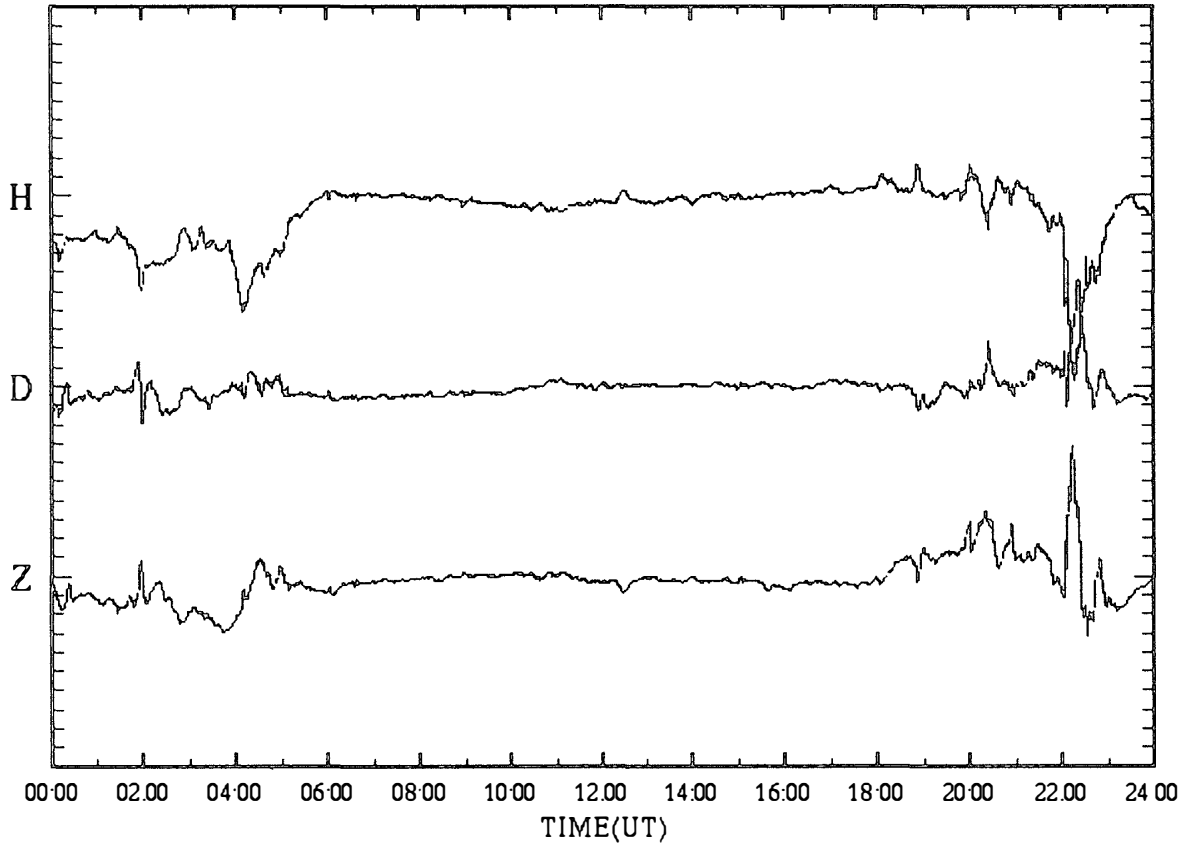

SYOWA magnetogram (100 nT/div)

30 Mar.1997 (DAY:089)

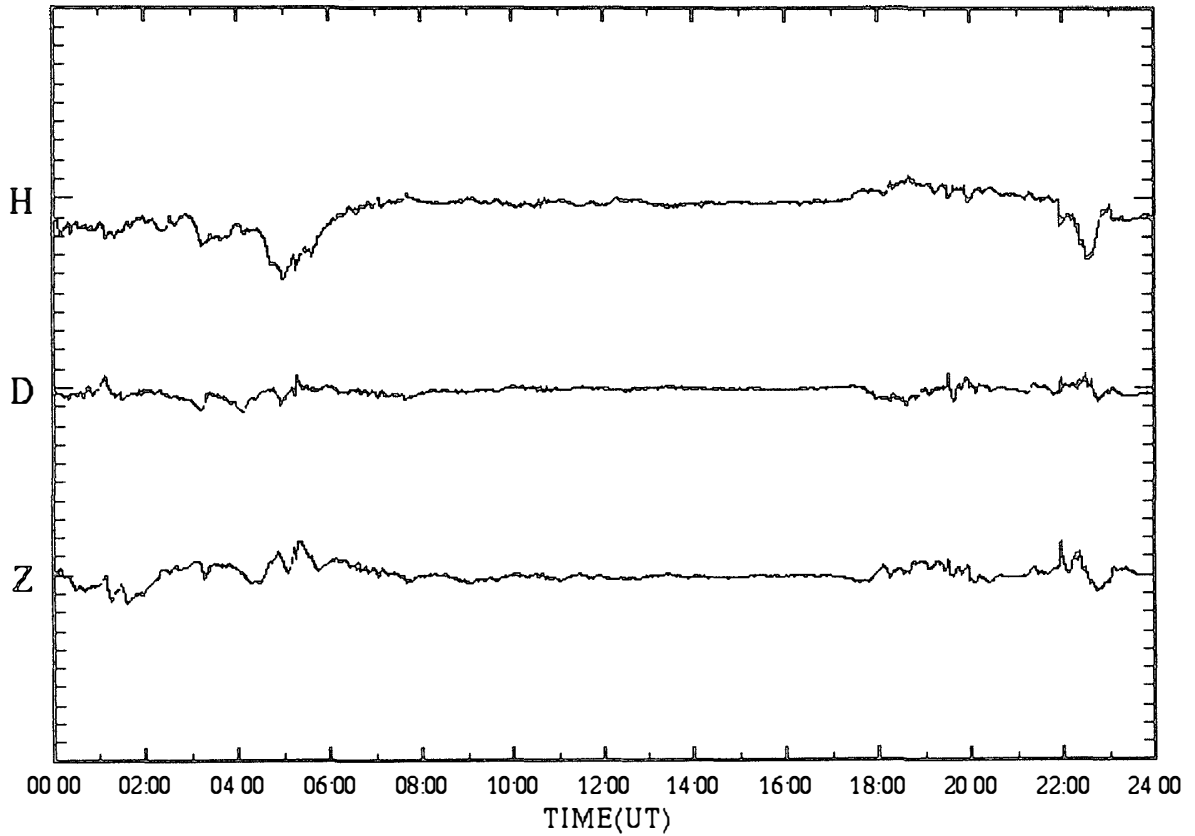

SYOWA magnetogram (100 nT/div)

31 Mar.1997 (DAY:090)

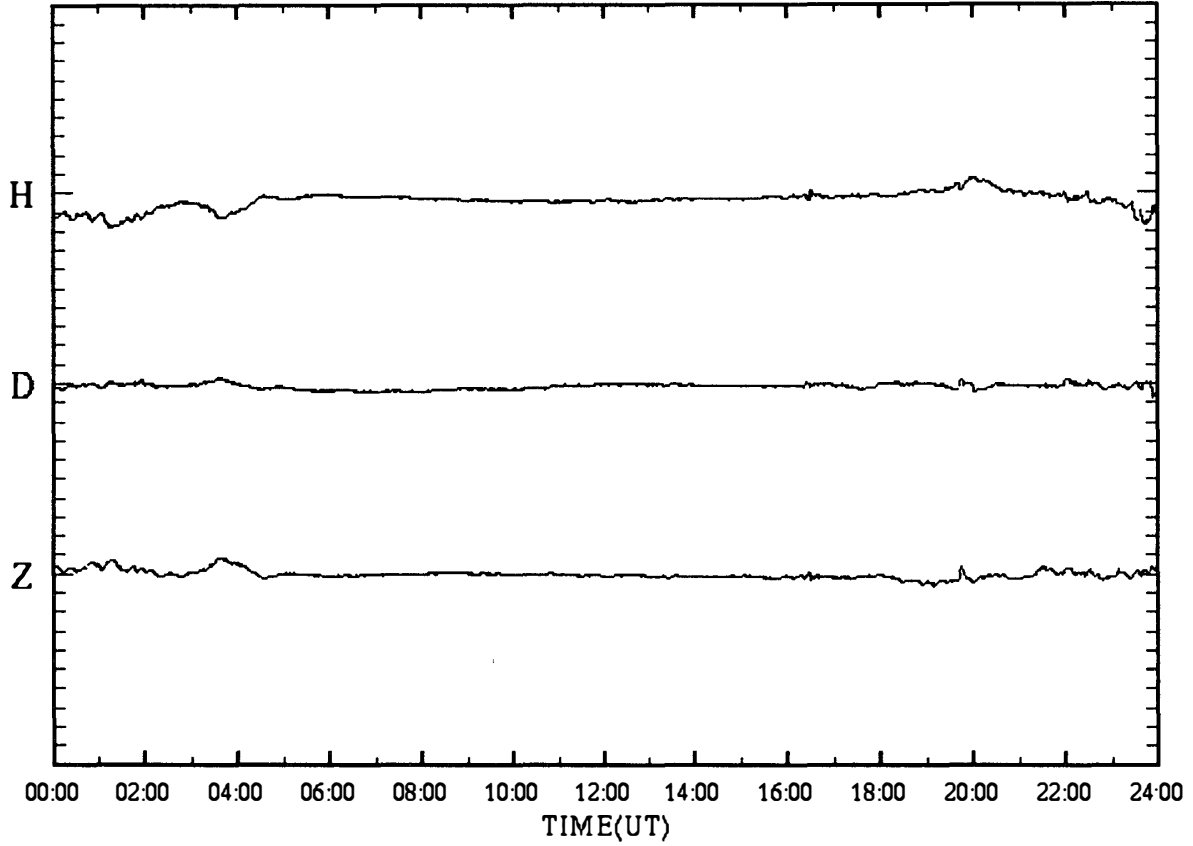

SYOWA magnetogram (100 nT/div)

01 Apr.1997 (DAY:091)

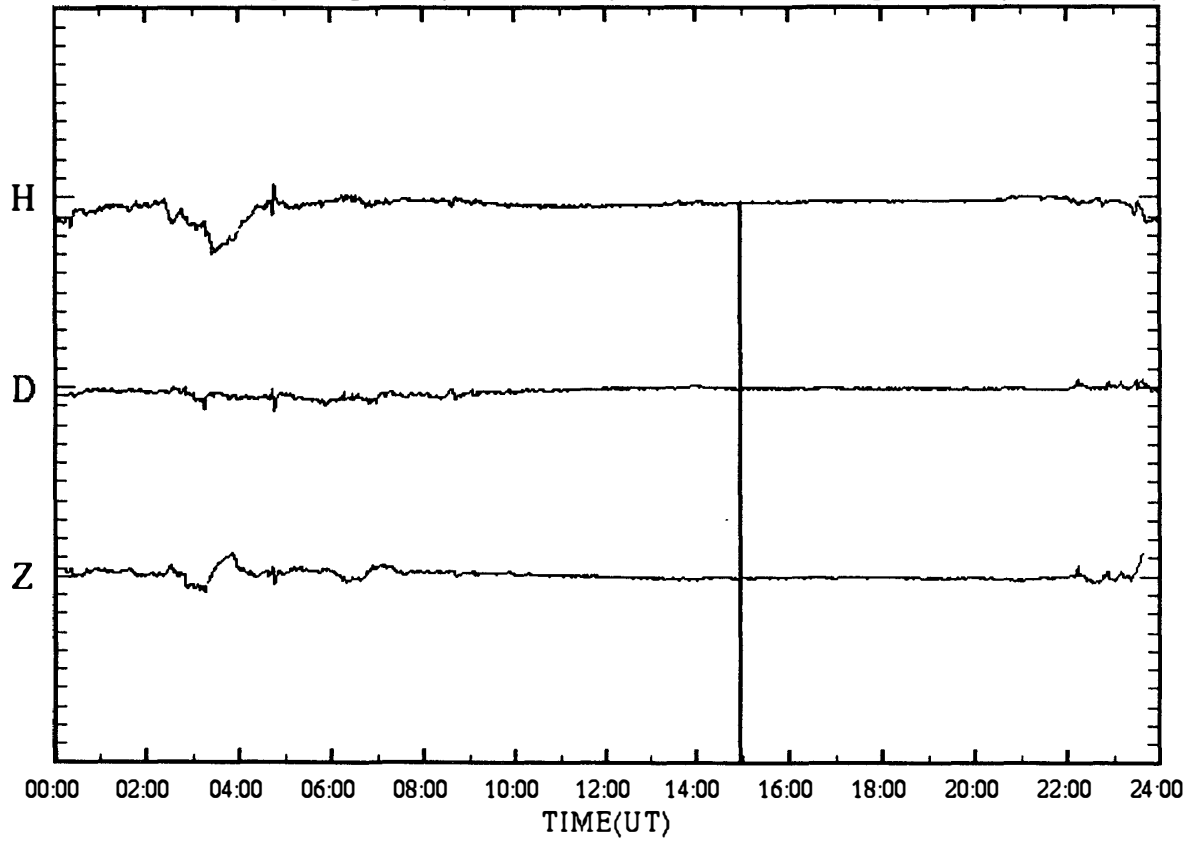

SYOWA magnetogram (100 nT/div)

02 Apr.1997 (DAY:092)

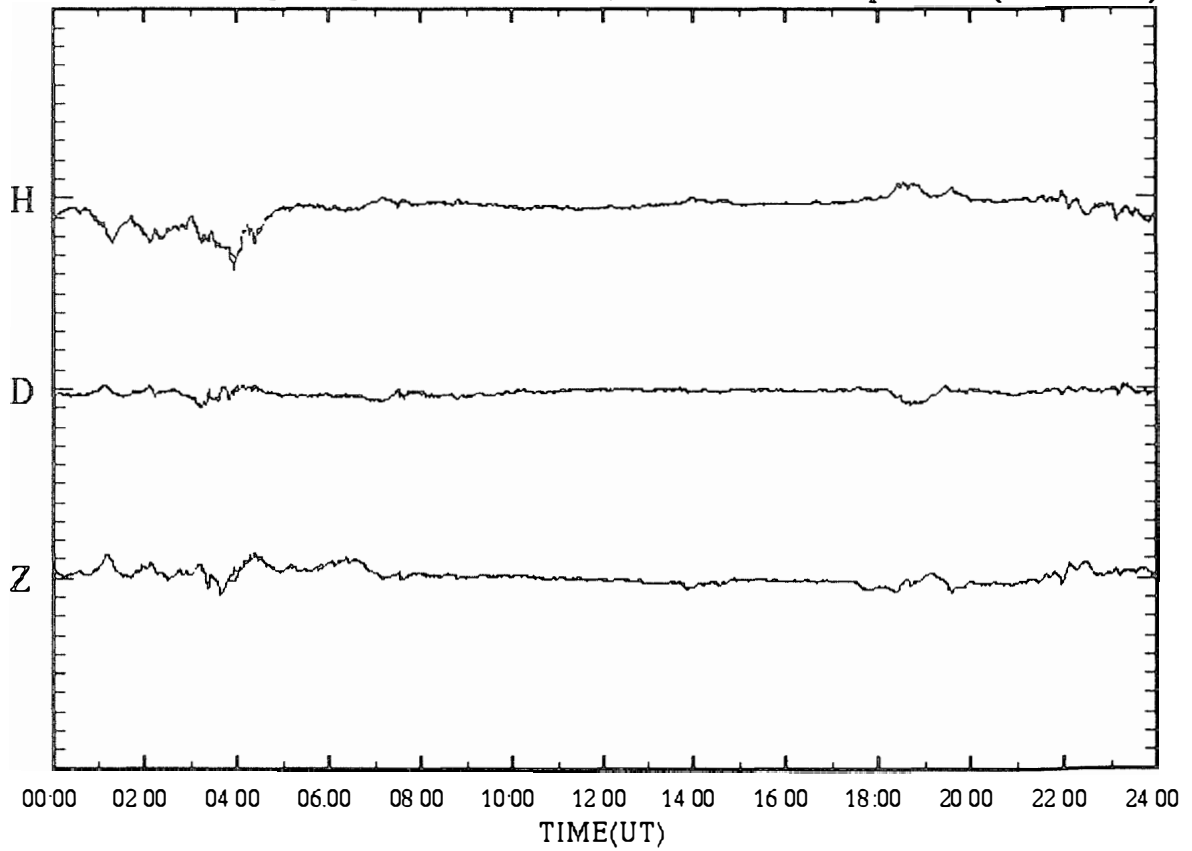

SYOWA magnetogram (100 nT/div)

03 Apr.1997 (DAY:093)

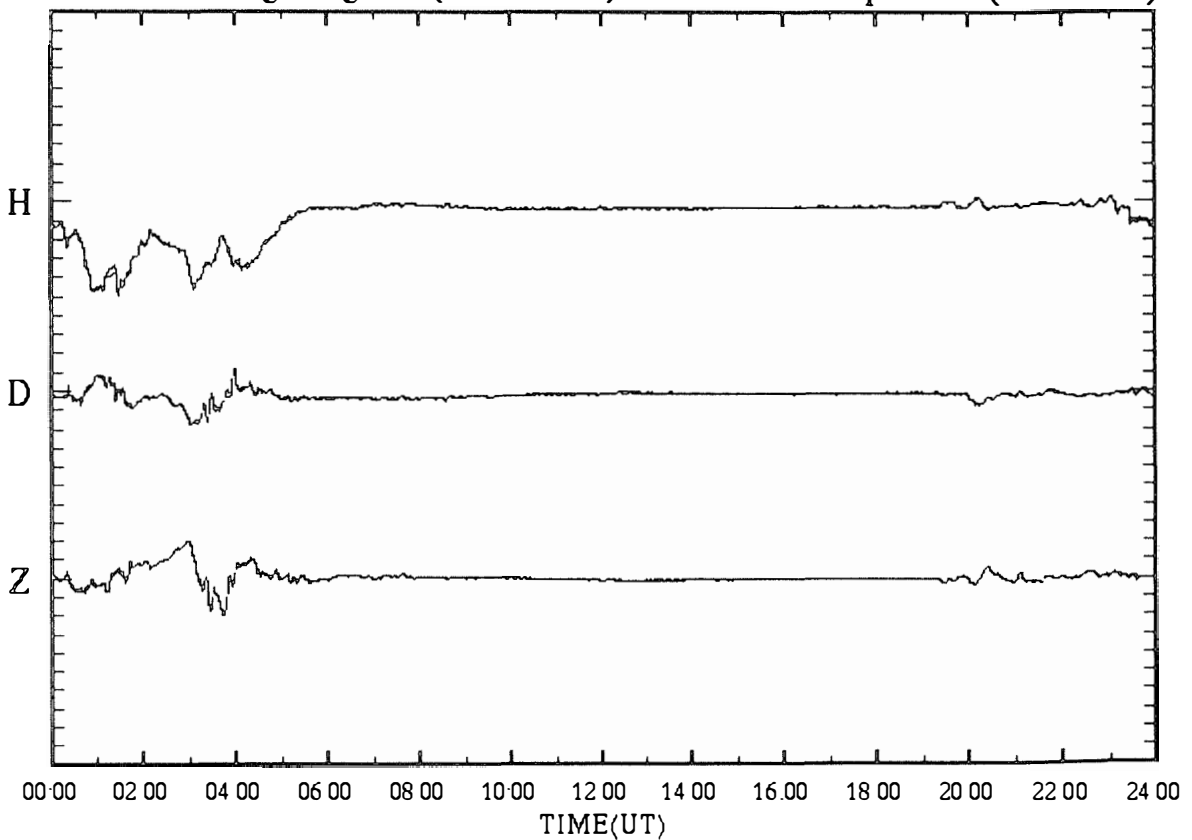

SYOWA magnetogram (100 nT/div)

04 Apr.1997 (DAY:094)

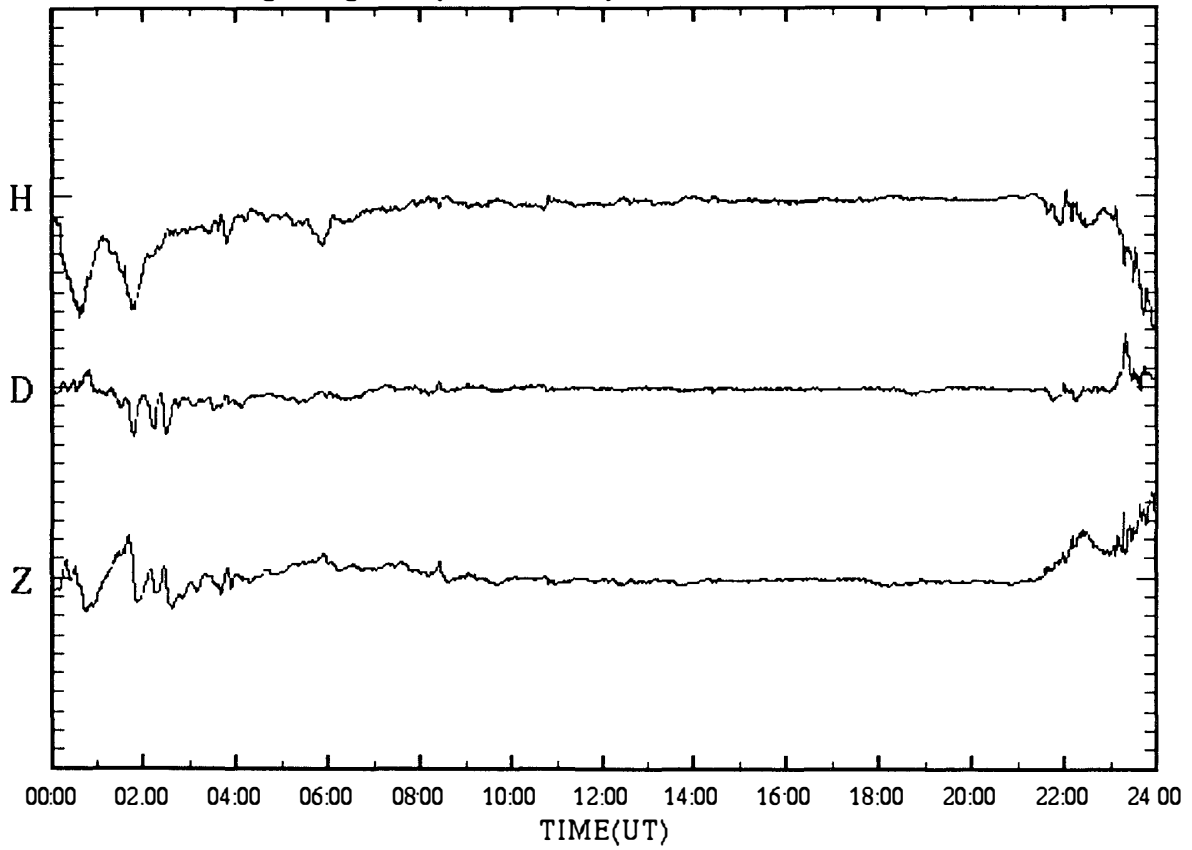

SYOWA magnetogram (100 nT/div)

05 Apr.1997 (DAY:095)

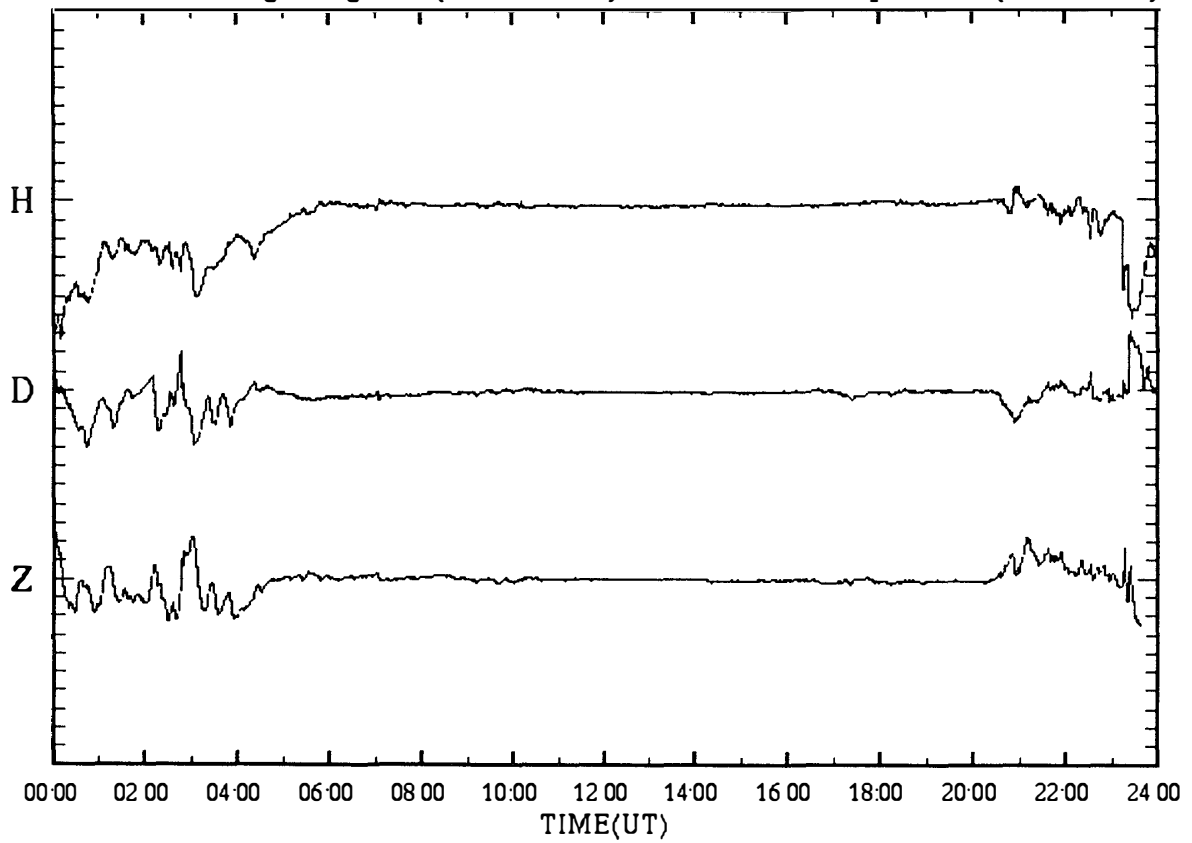

SYOWA magnetogram (100 nT/div)

06 Apr.1997 (DAY:096)

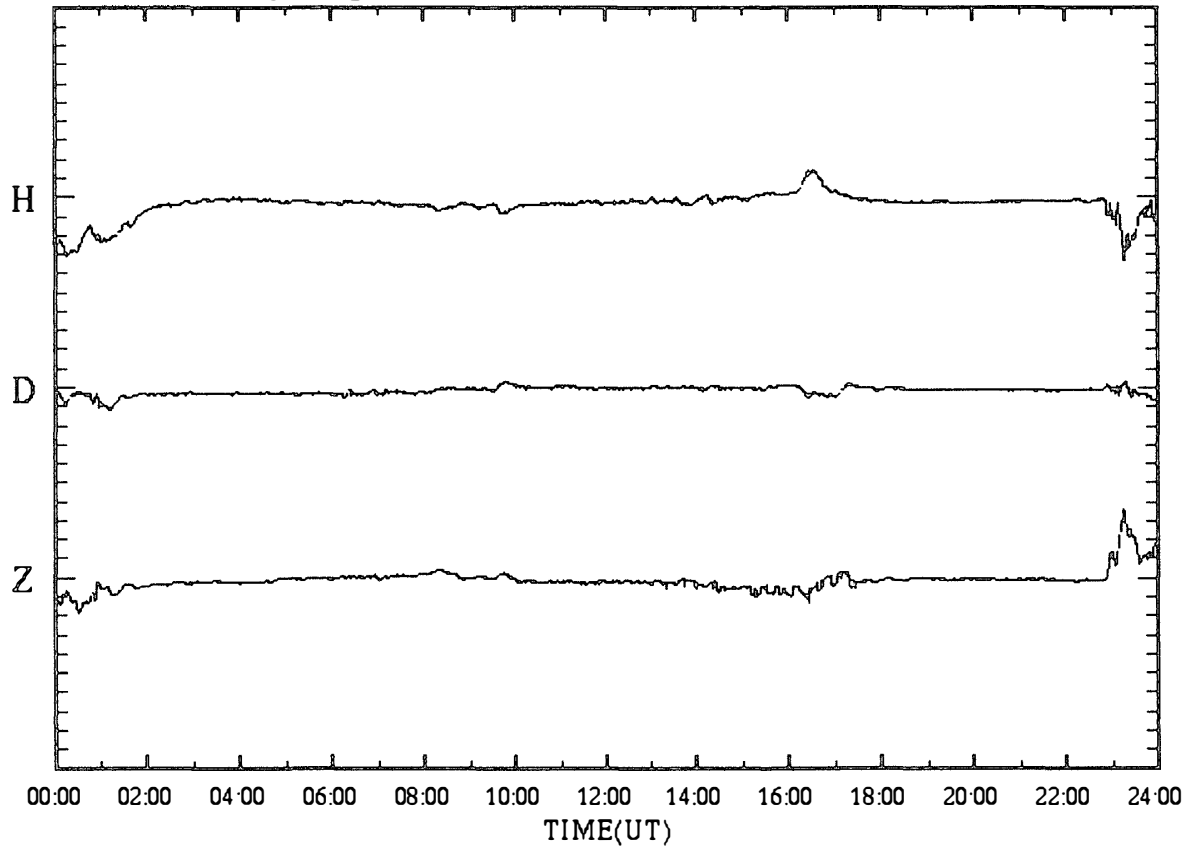

SYOWA magnetogram (100 nT/div)

07 Apr.1997 (DAY:097)

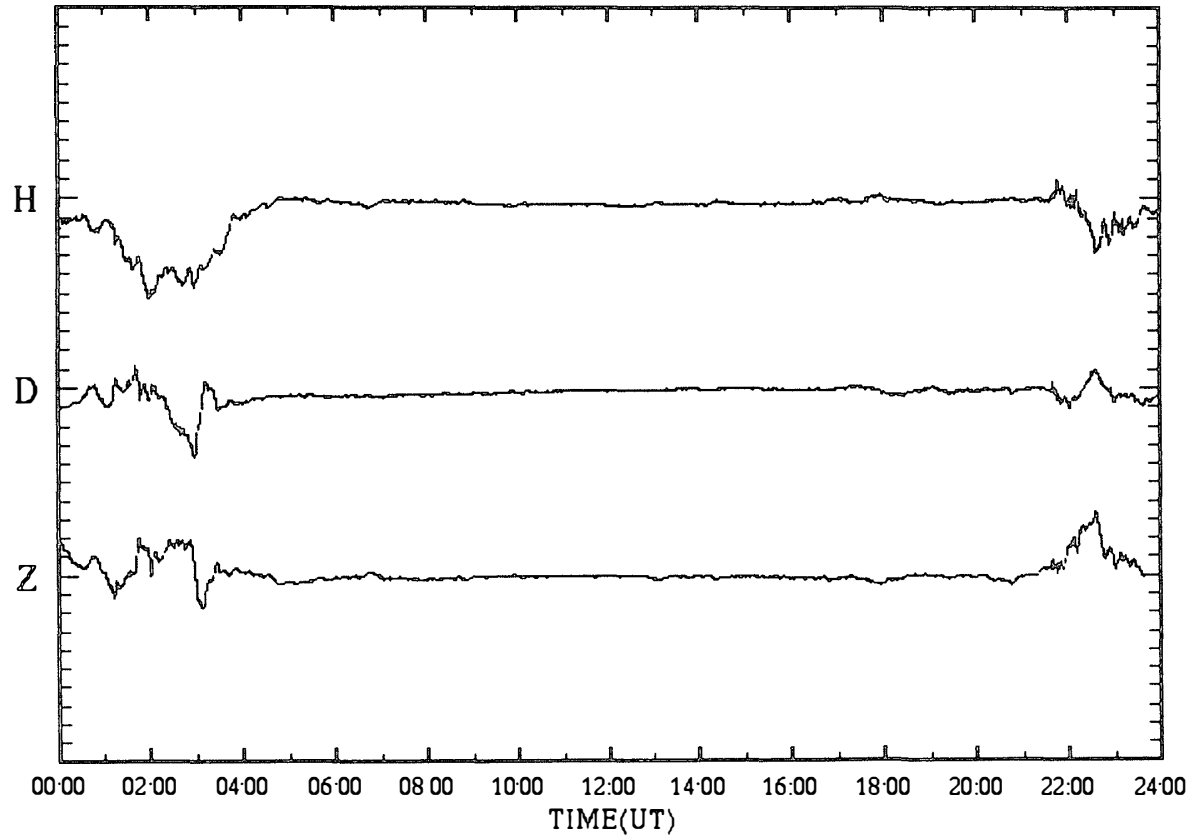

SYOWA magnetogram (100 nT/div)

08 Apr.1997 (DAY:098)

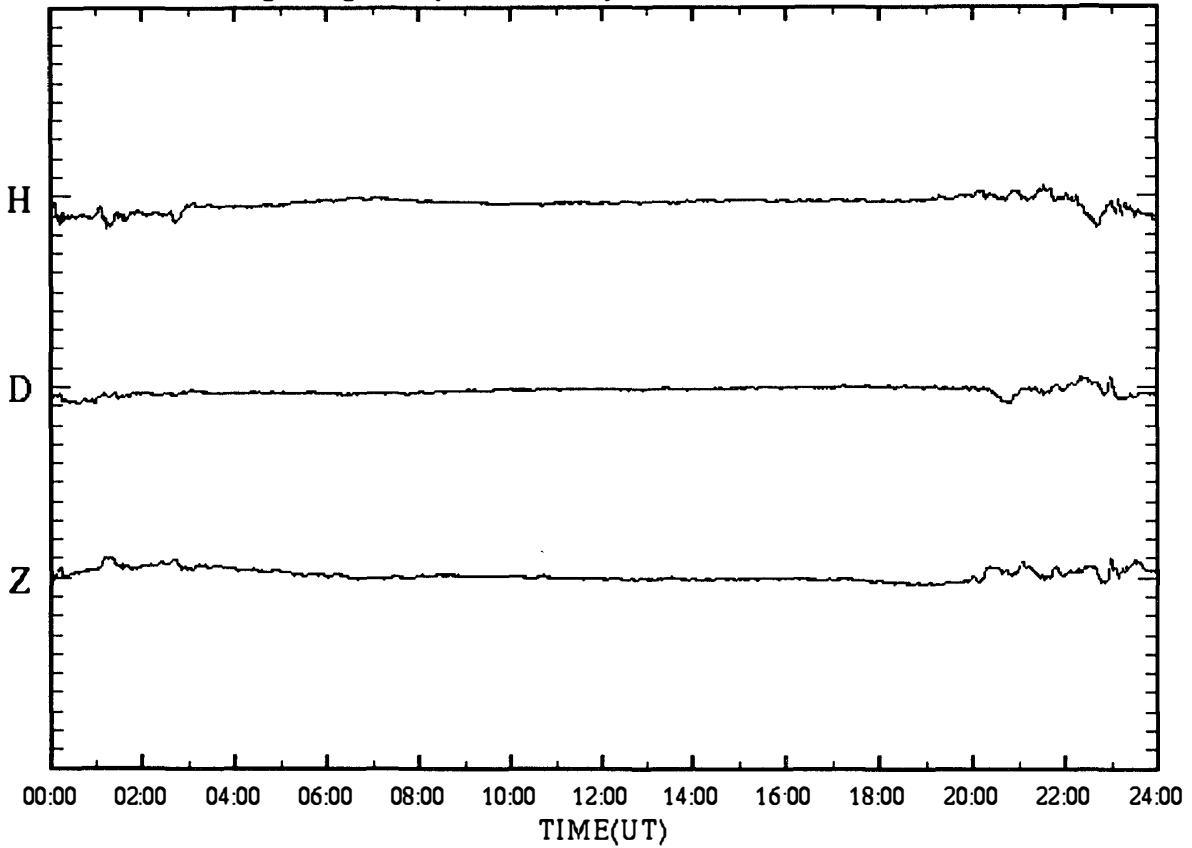

SYOWA magnetogram (100 nT/div)

09 Apr.1997 (DAY:099)

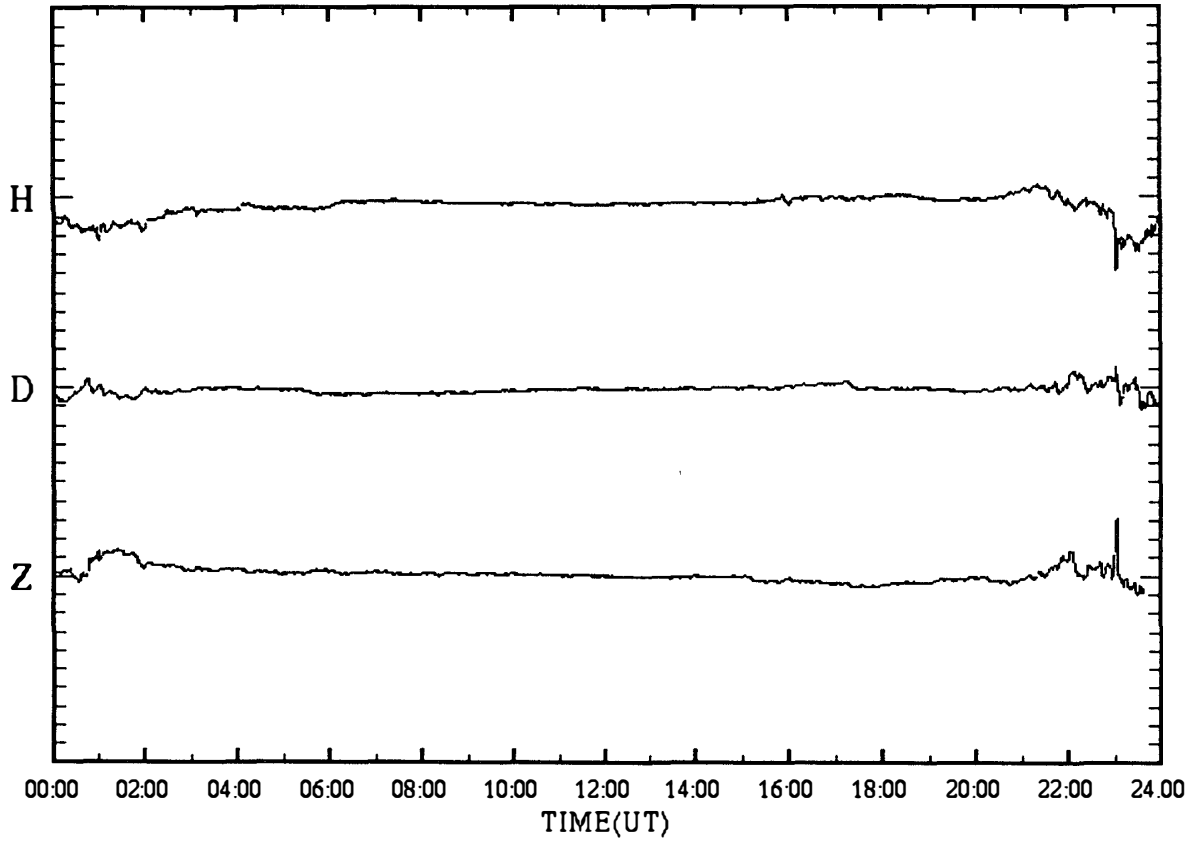

SYOWA magnetogram (100 nT/div)

10 Apr.1997 (DAY:100)

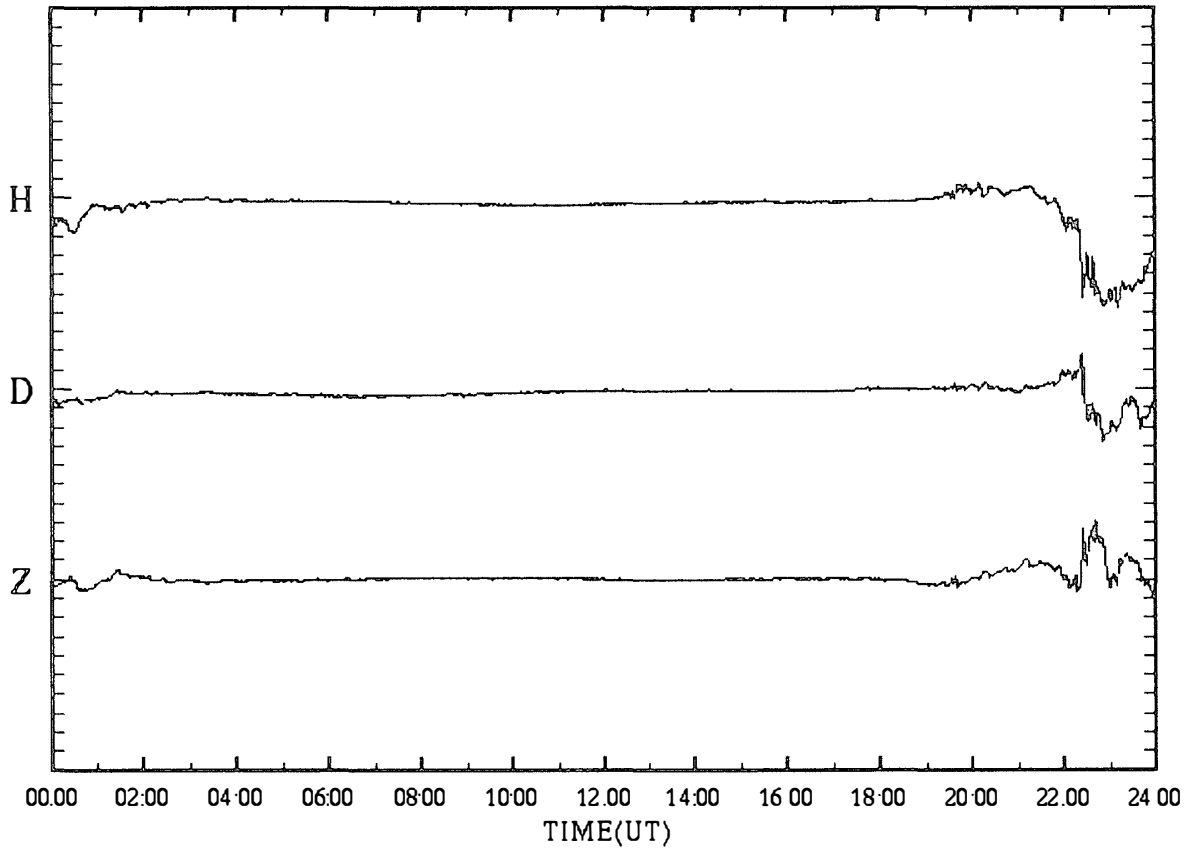

SYOWA magnetogram (100 nT/div)

11 Apr.1997 (DAY:101)

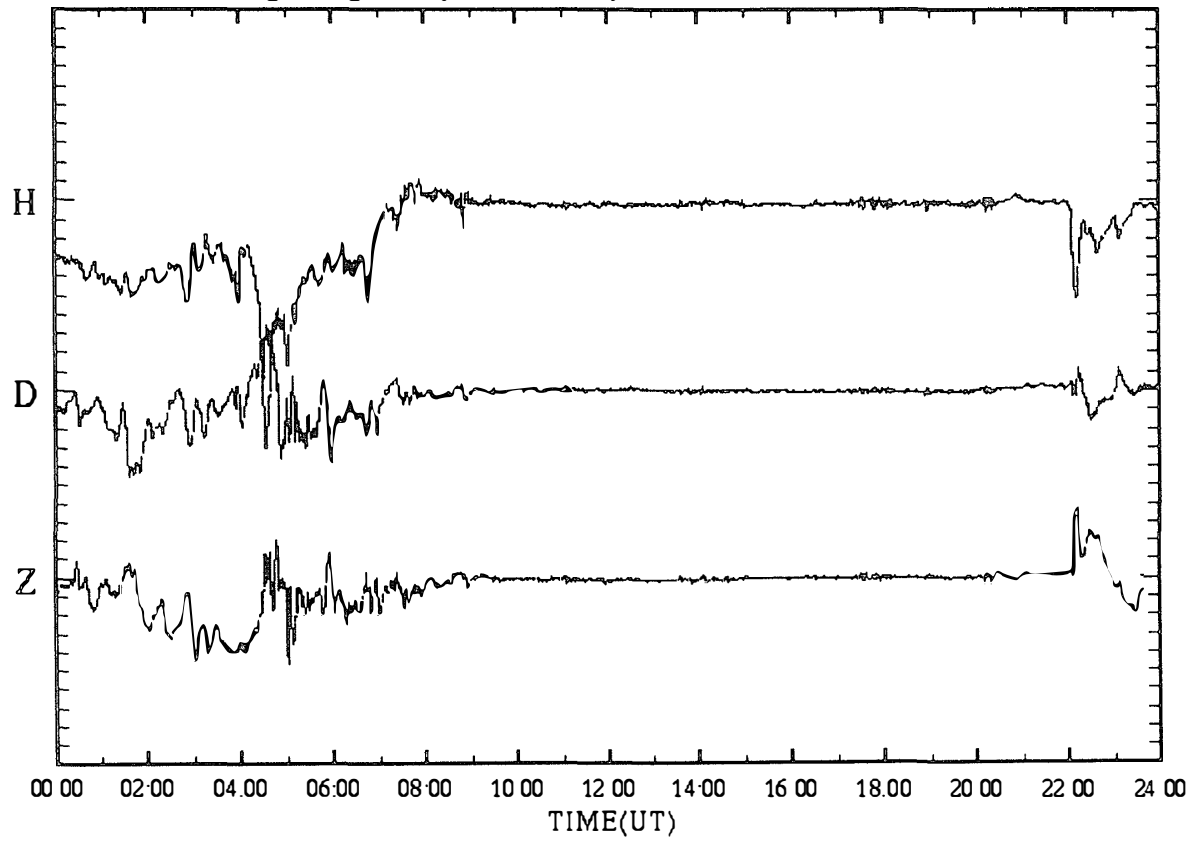



SYOWA magnetogram (100 nT/div)

12 Apr.1997 (DAY:102)

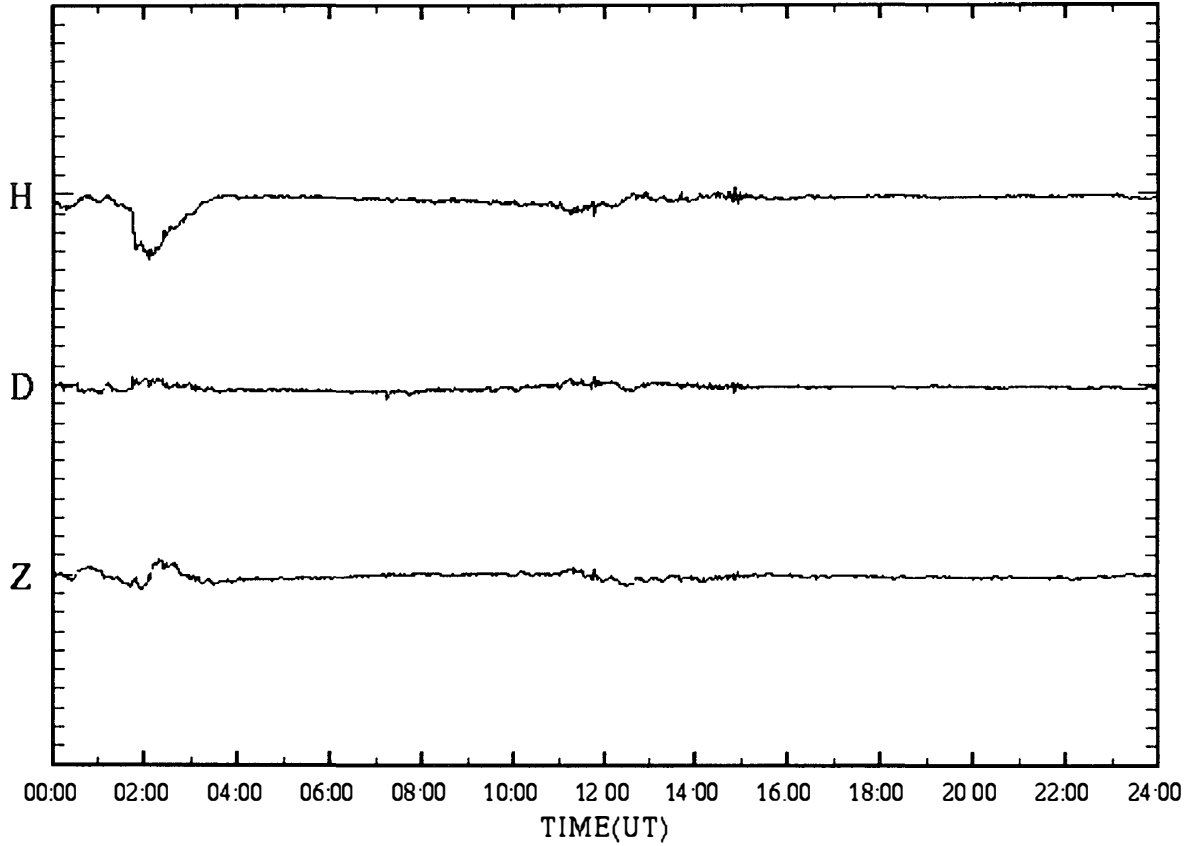

SYOWA magnetogram (100 nT/div)

13 Apr.1997 (DAY:103)

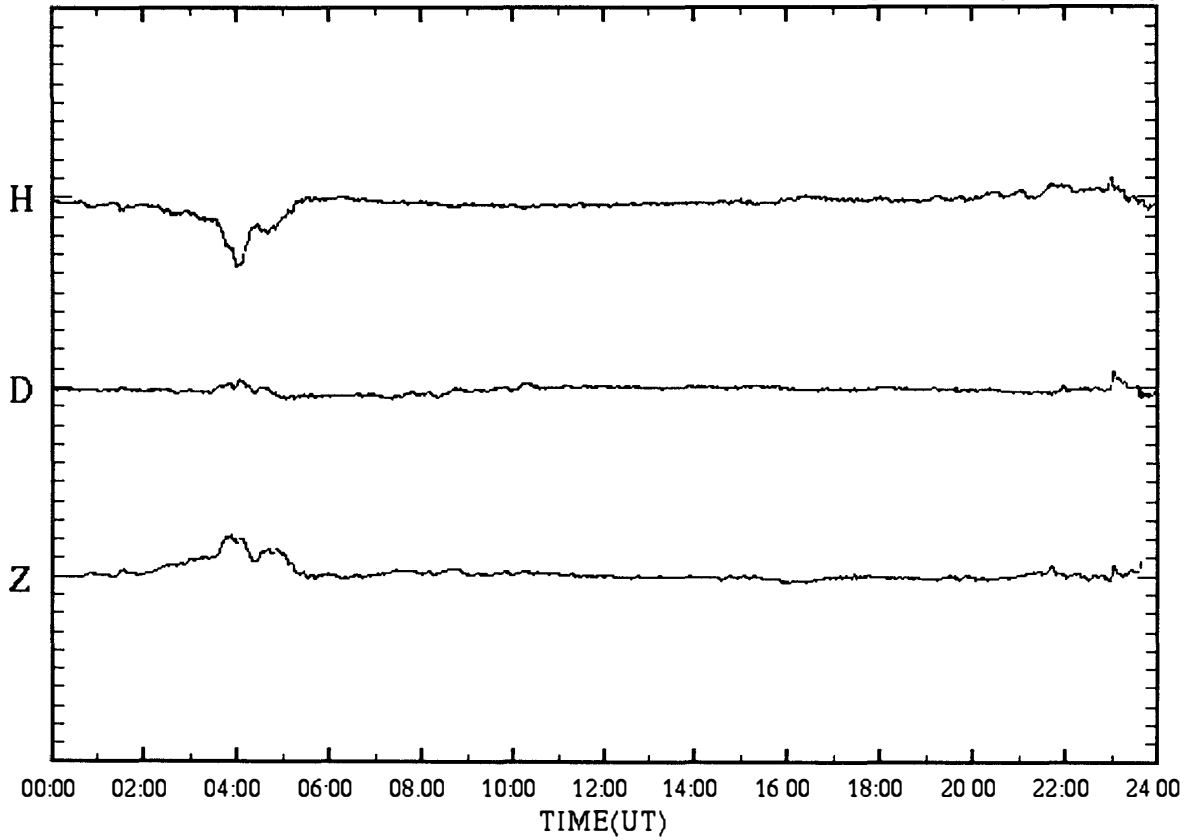

SYOWA magnetogram (100 nT/div)

14 Apr.1997 (DAY:104)

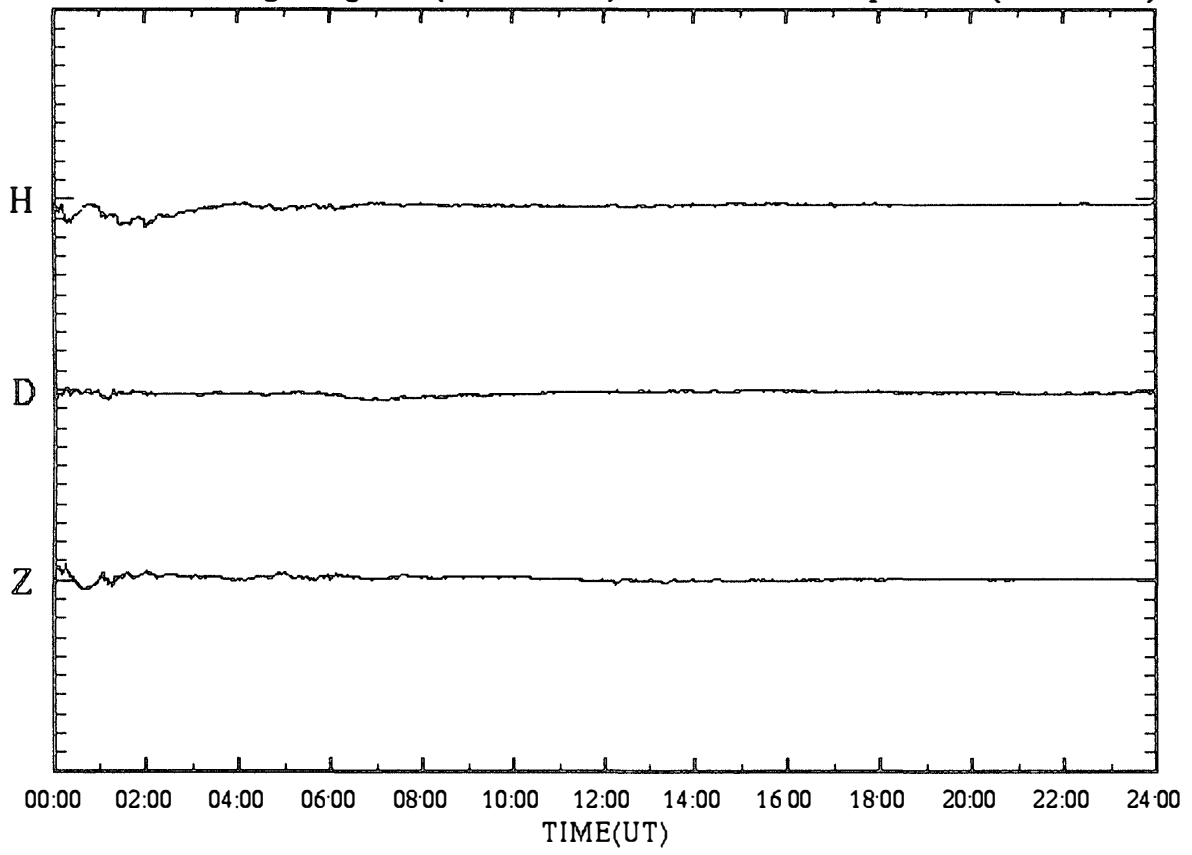

SYOWA magnetogram (100 nT/div)

15 Apr.1997 (DAY:105)

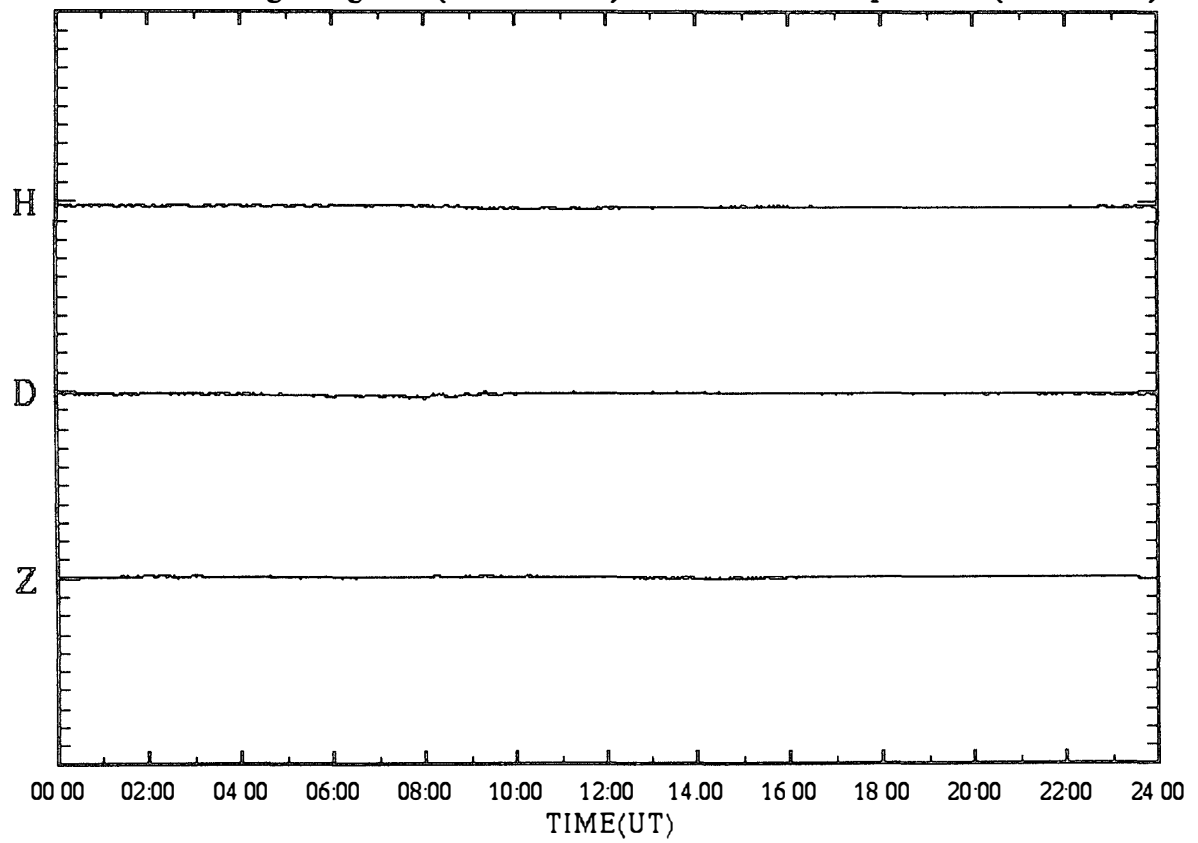

SYOWA magnetogram (100 nT/div)

16 Apr.1997 (DAY:106)

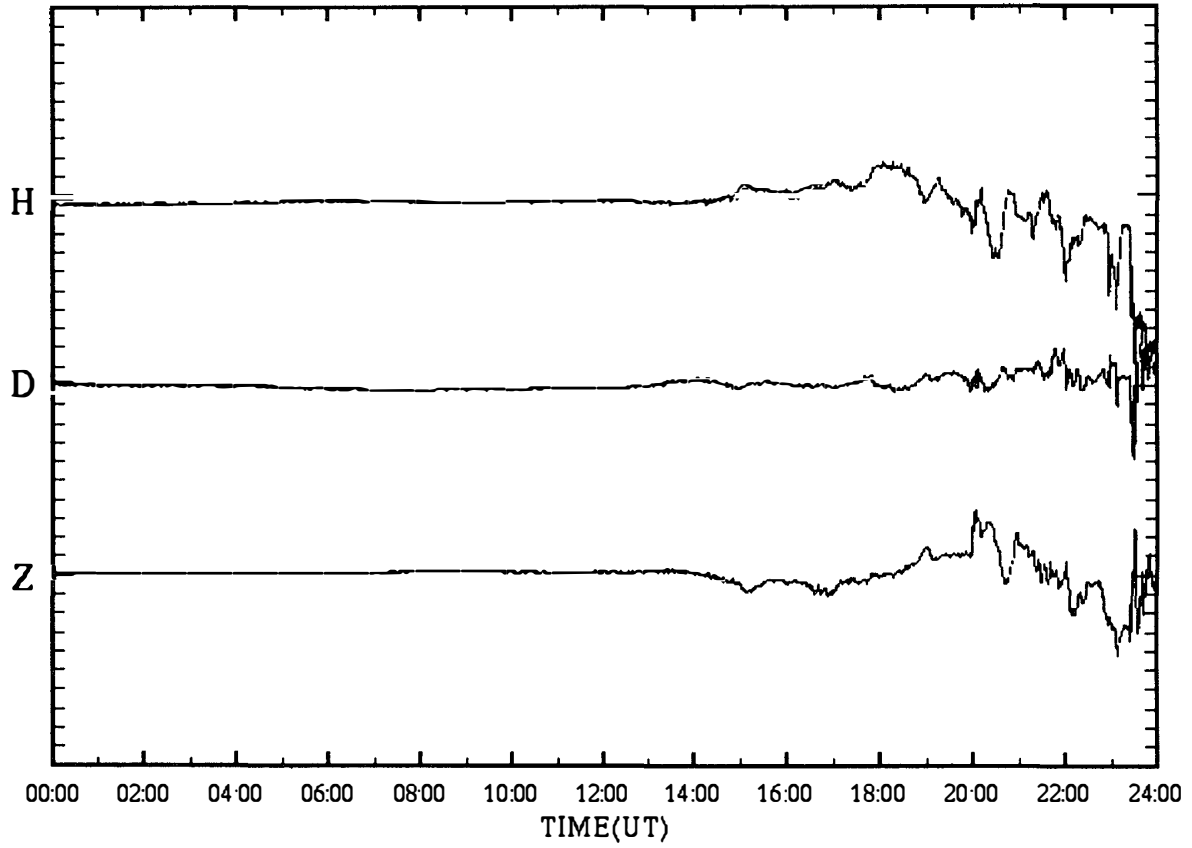

SYOWA magnetogram (100 nT/div)

17 Apr.1997 (DAY:107)

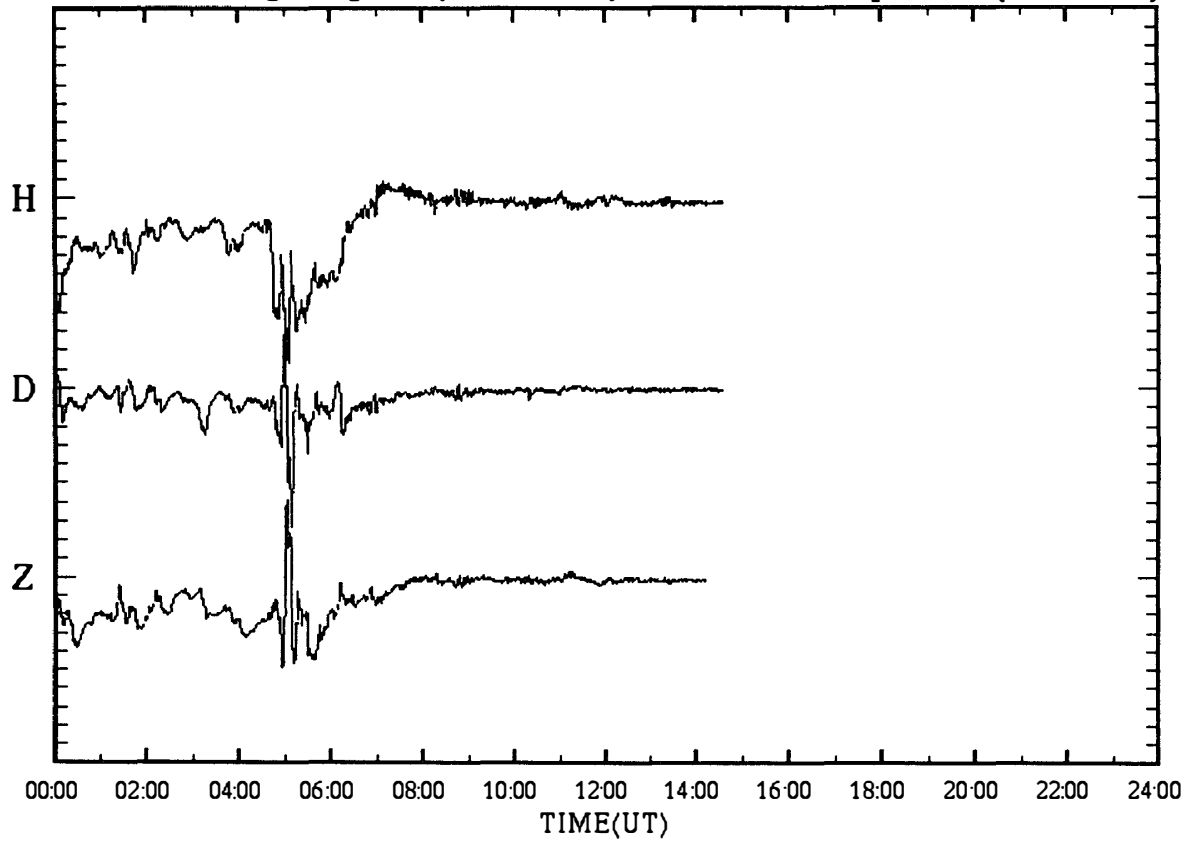

SYOWA magnetogram (100 nT/div)

18 Apr.1997 (DAY:108)

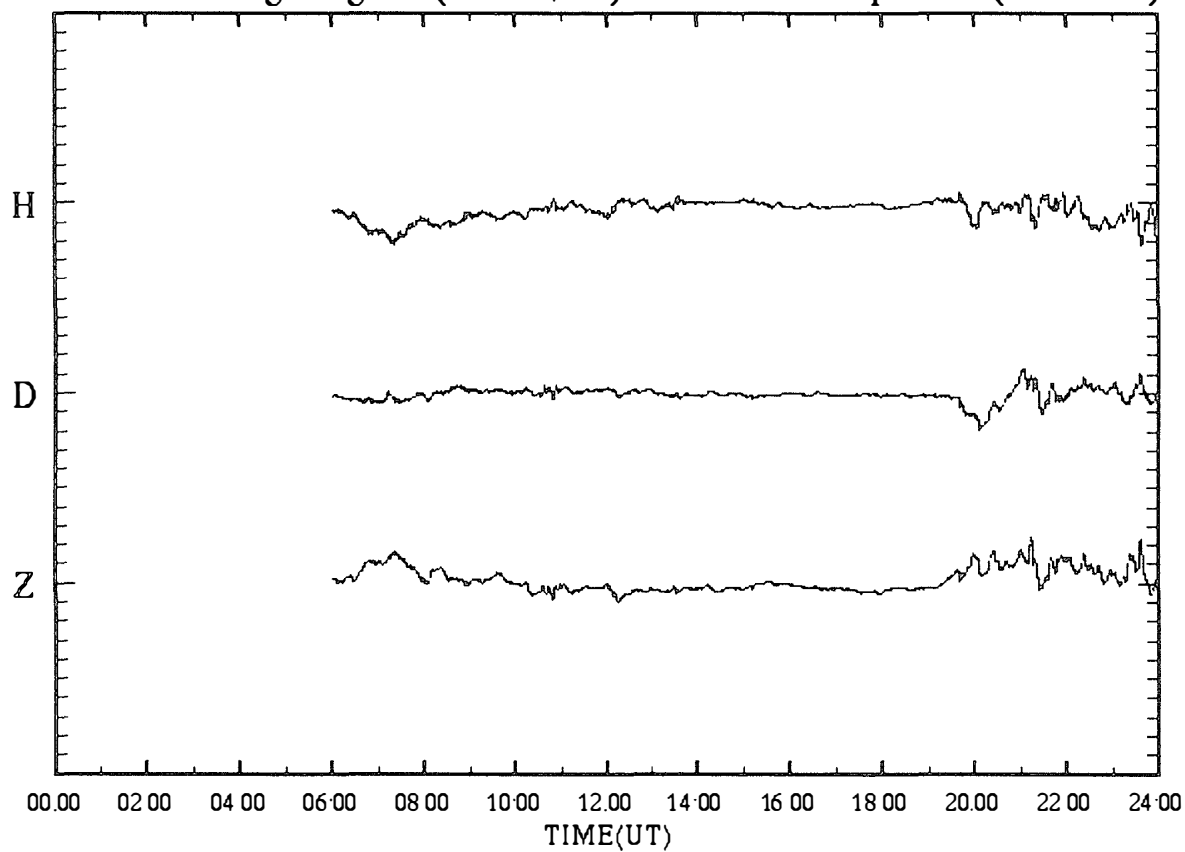

SYOWA magnetogram (100 nT/div)

19 Apr.1997 (DAY:109)

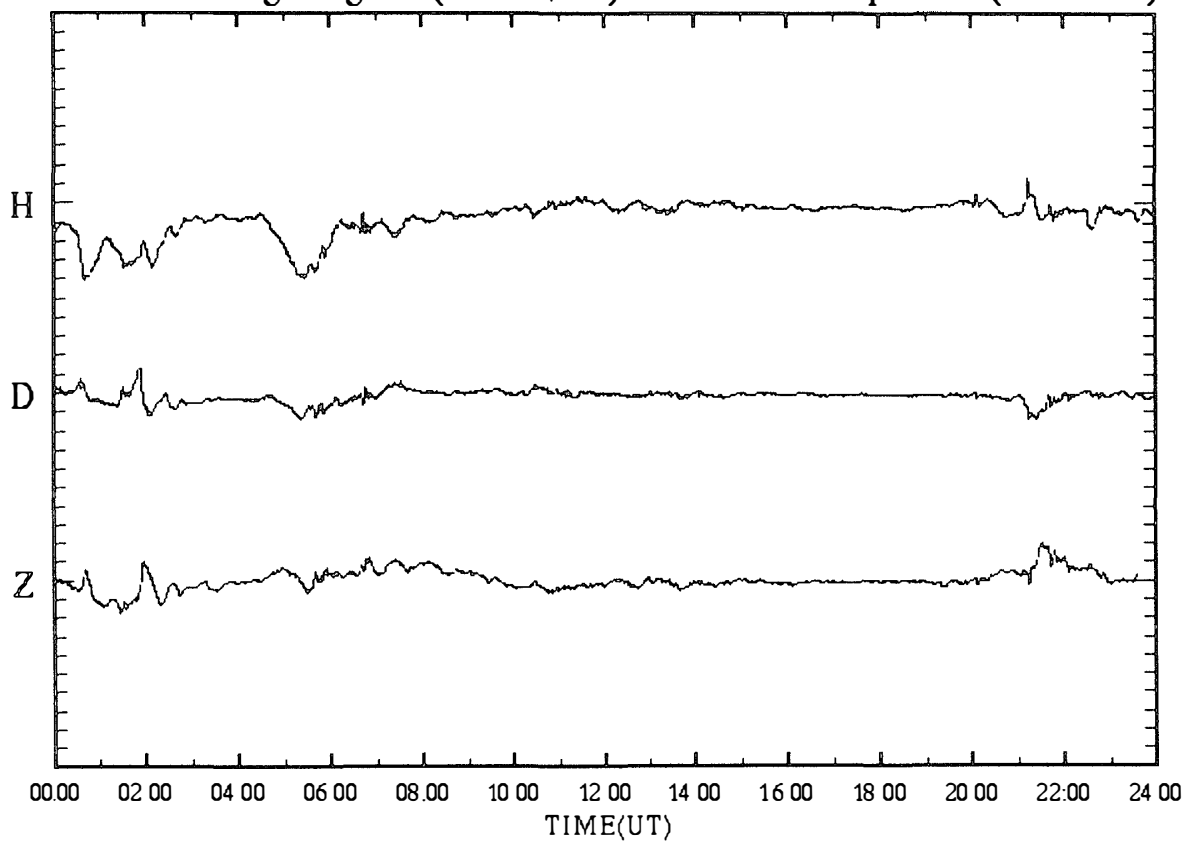

SYOWA magnetogram (100 nT/div)

20 Apr.1997 (DAY:110)

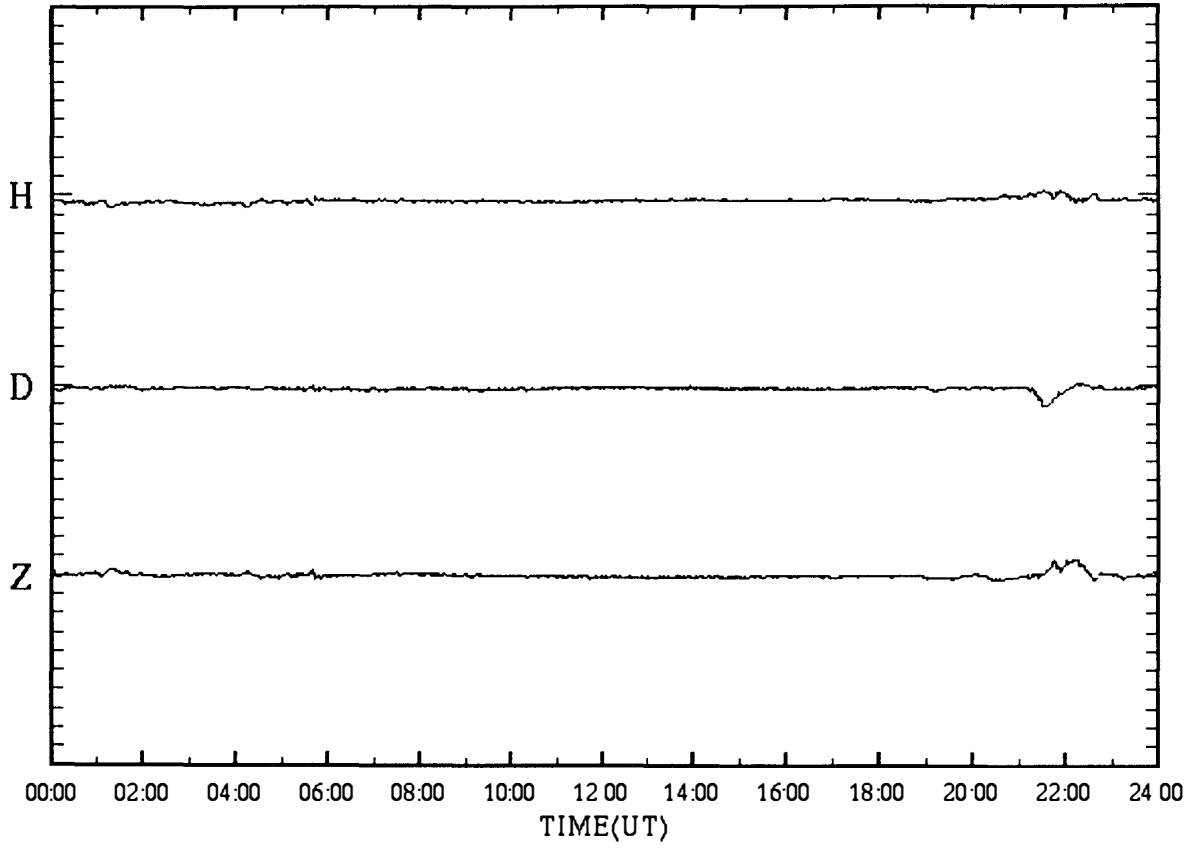

SYOWA magnetogram (100 nT/div)

21 Apr.1997 (DAY:111)

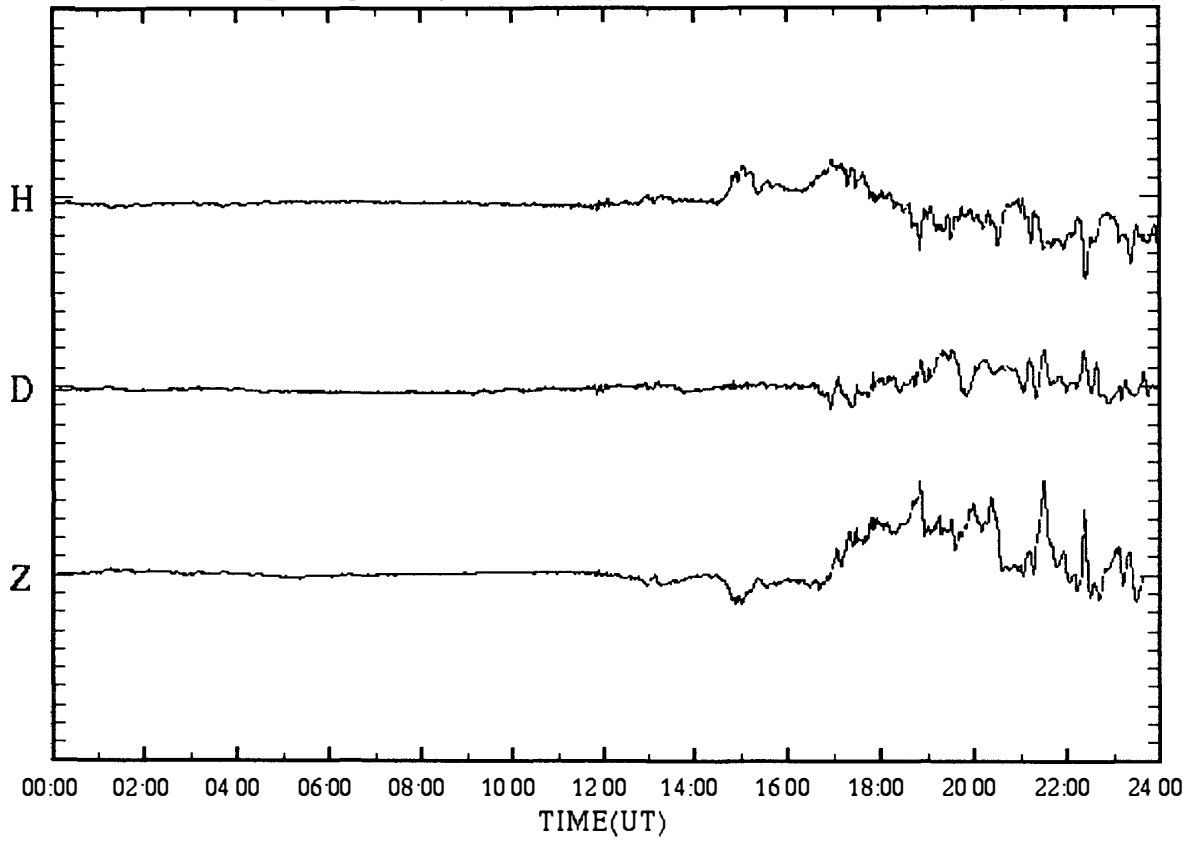

SYOWA magnetogram (100 nT/div)

22 Apr.1997 (DAY:112)

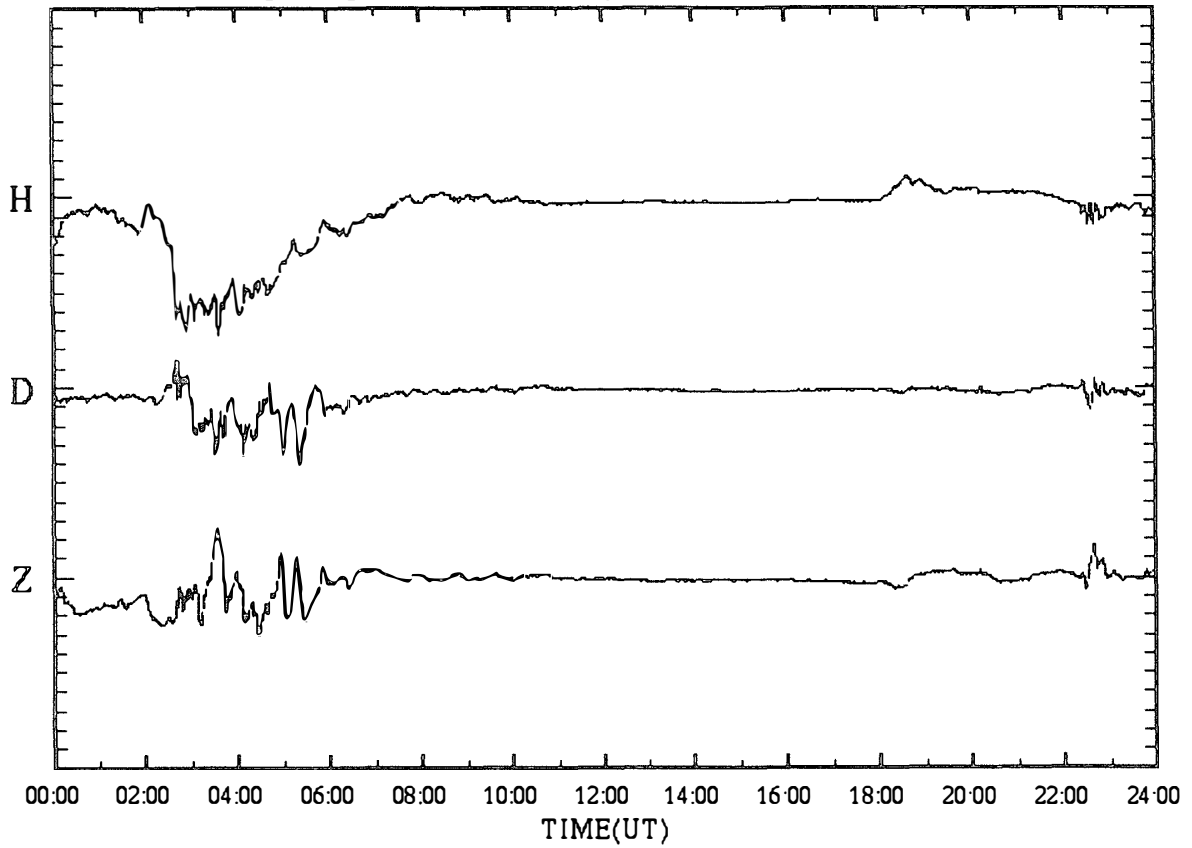

SYOWA magnetogram (100 nT/div)

23 Apr.1997 (DAY:113)

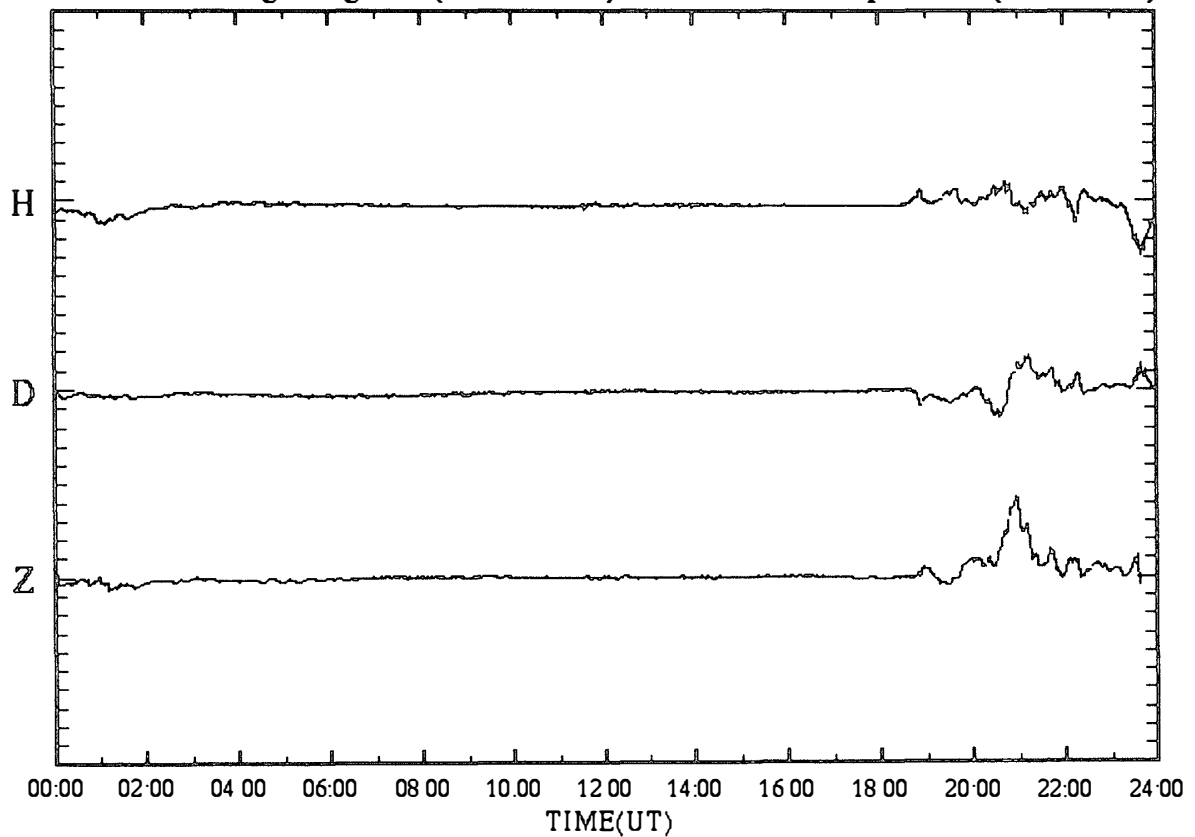

SYOWA magnetogram (100 nT/div)

24 Apr.1997 (DAY:114)

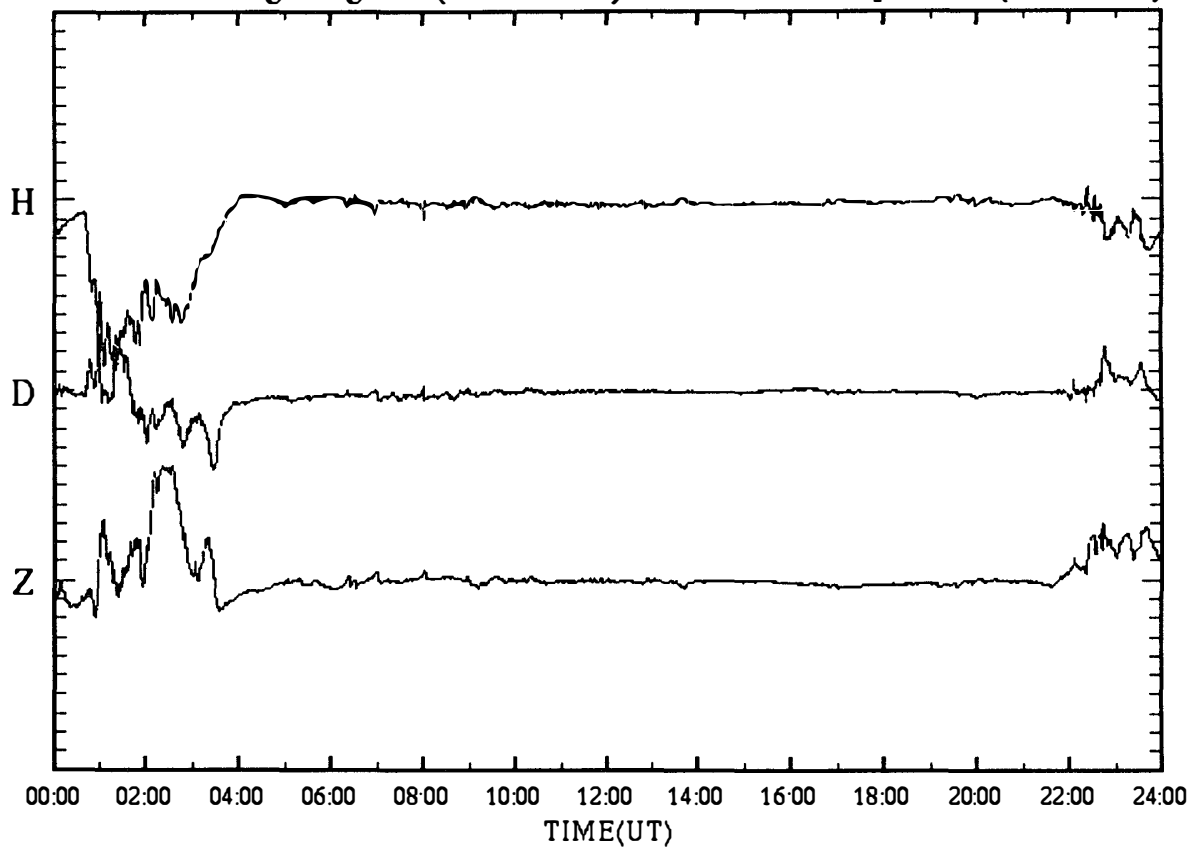

SYOWA magnetogram (100 nT/div)

25 Apr.1997 (DAY:115)

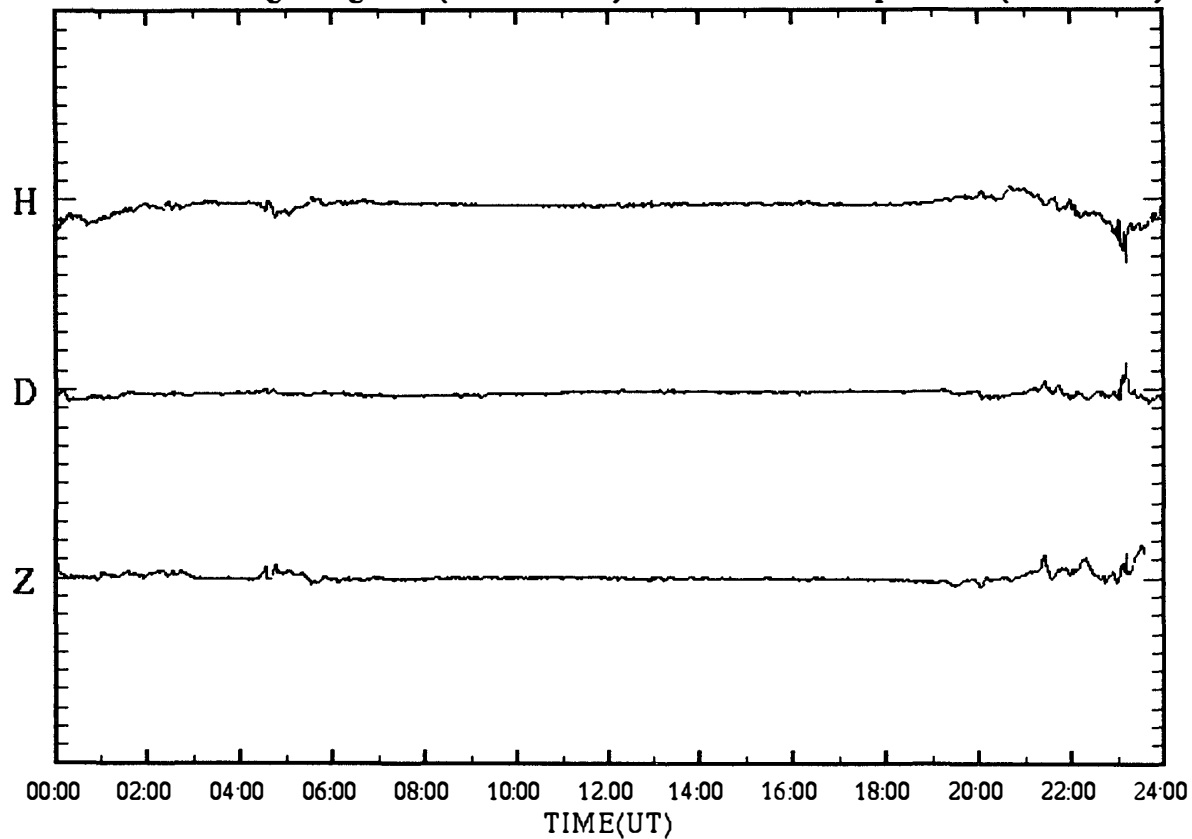

SYOWA magnetogram (100 nT/div)

26 Apr.1997 (DAY:116)

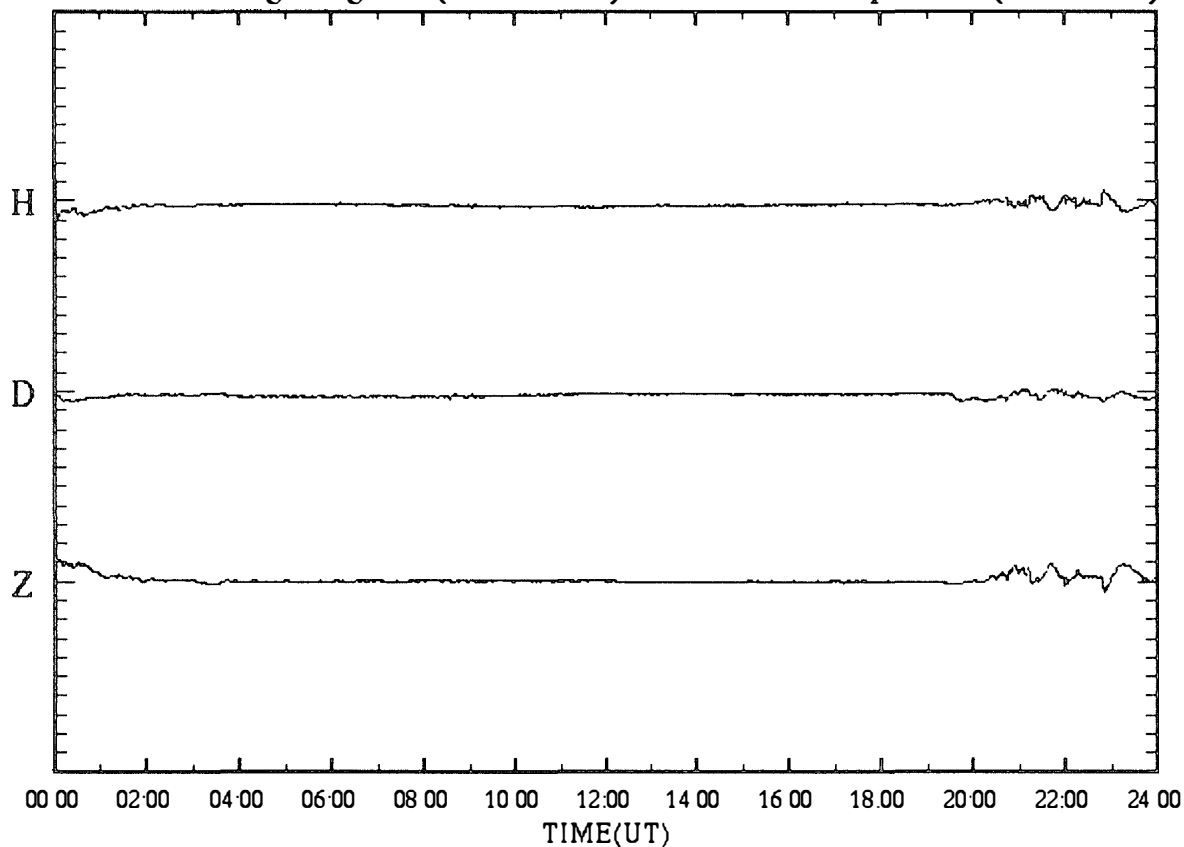

SYOWA magnetogram (100 nT/div)

27 Apr.1997 (DAY:117)

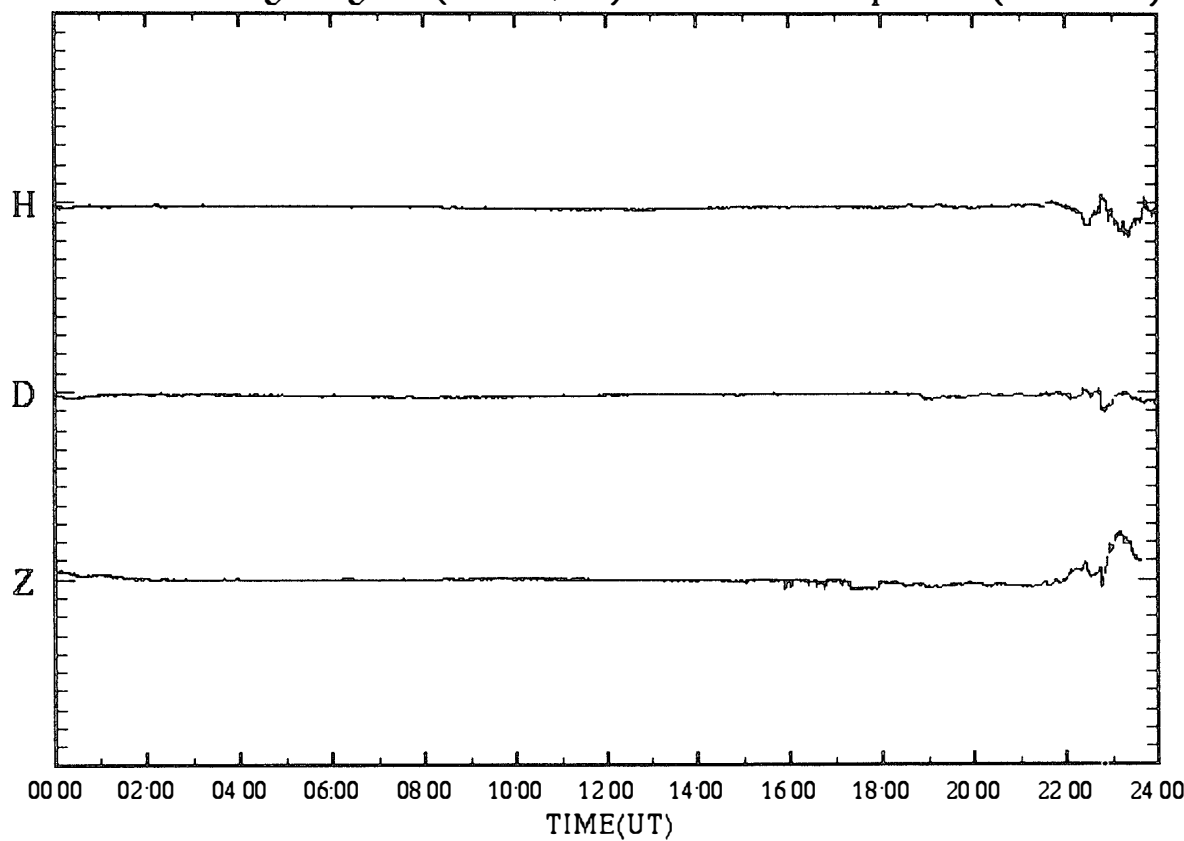



SYOWA magnetogram (100 nT/div)

28 Apr.1997 (DAY:118)

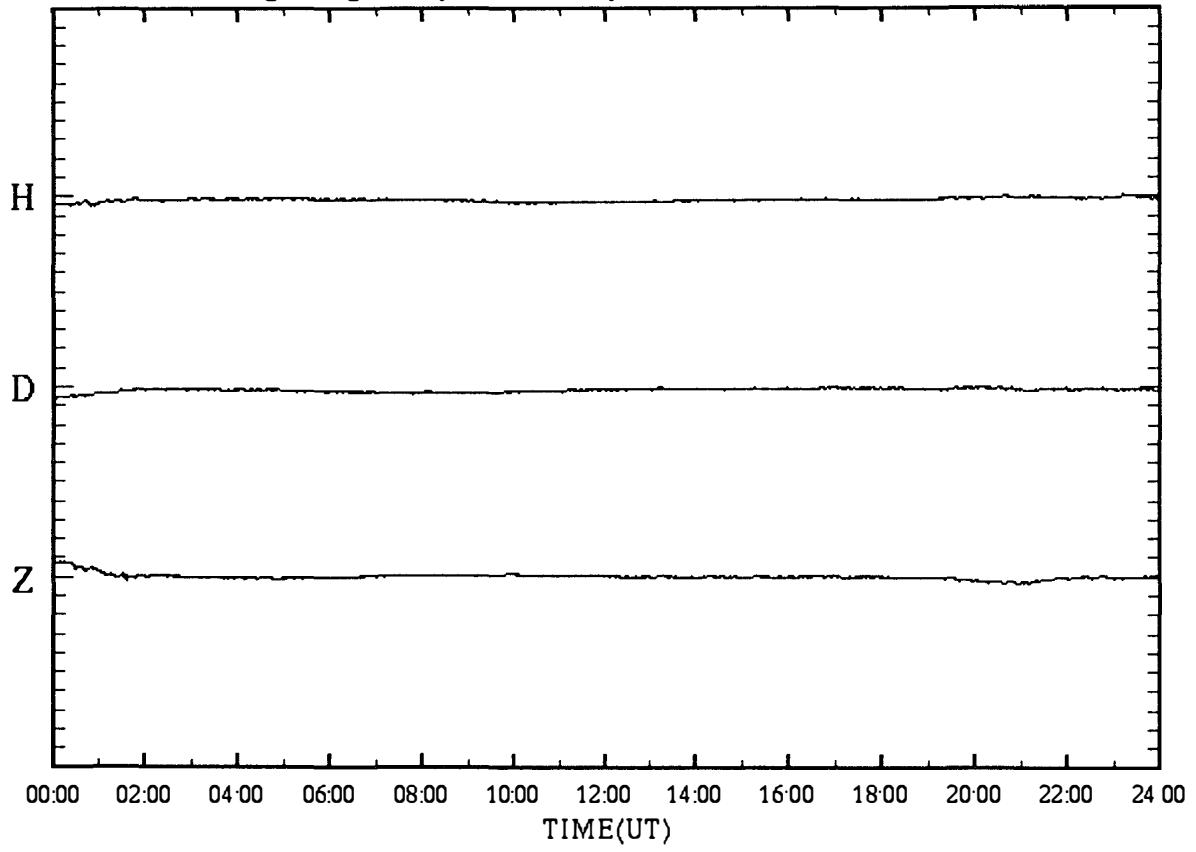

SYOWA magnetogram (100 nT/div)

29 Apr.1997 (DAY:119)

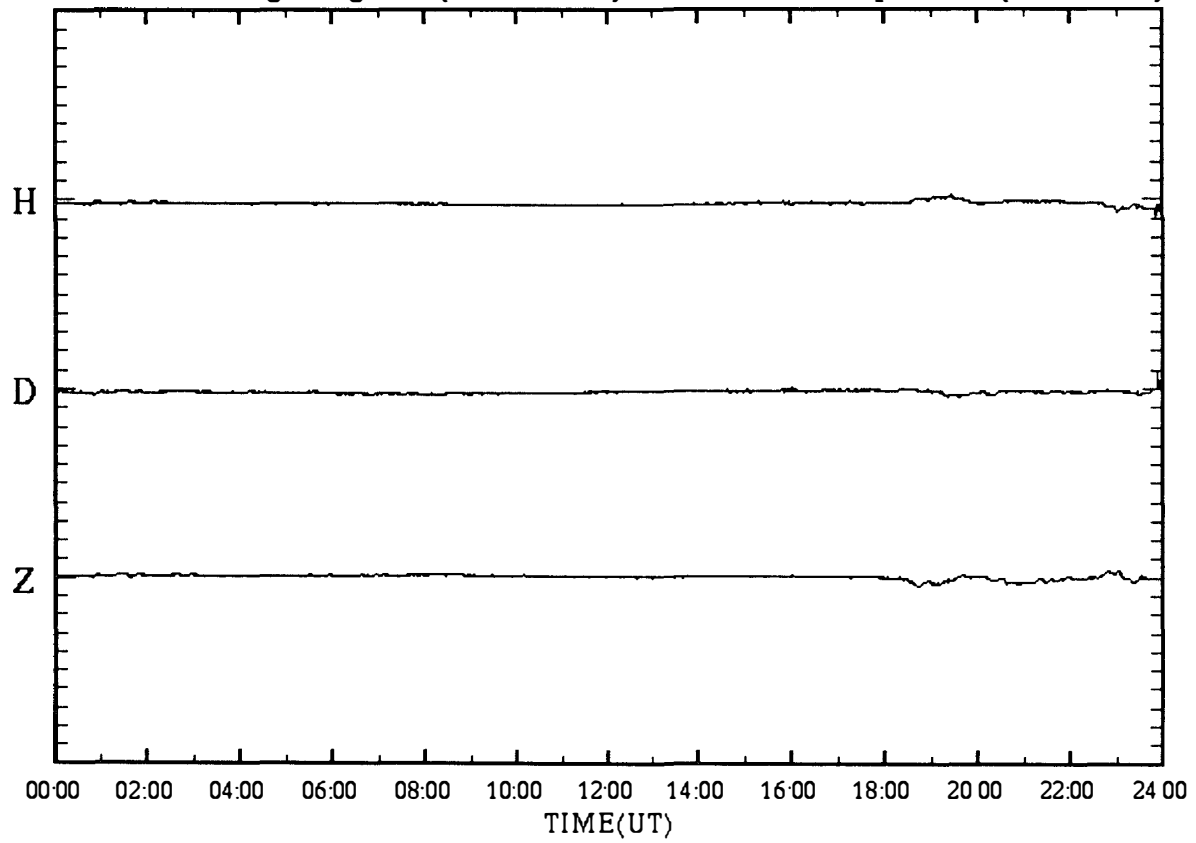

SYOWA magnetogram (100 nT/div)

30 Apr.1997 (DAY:120)

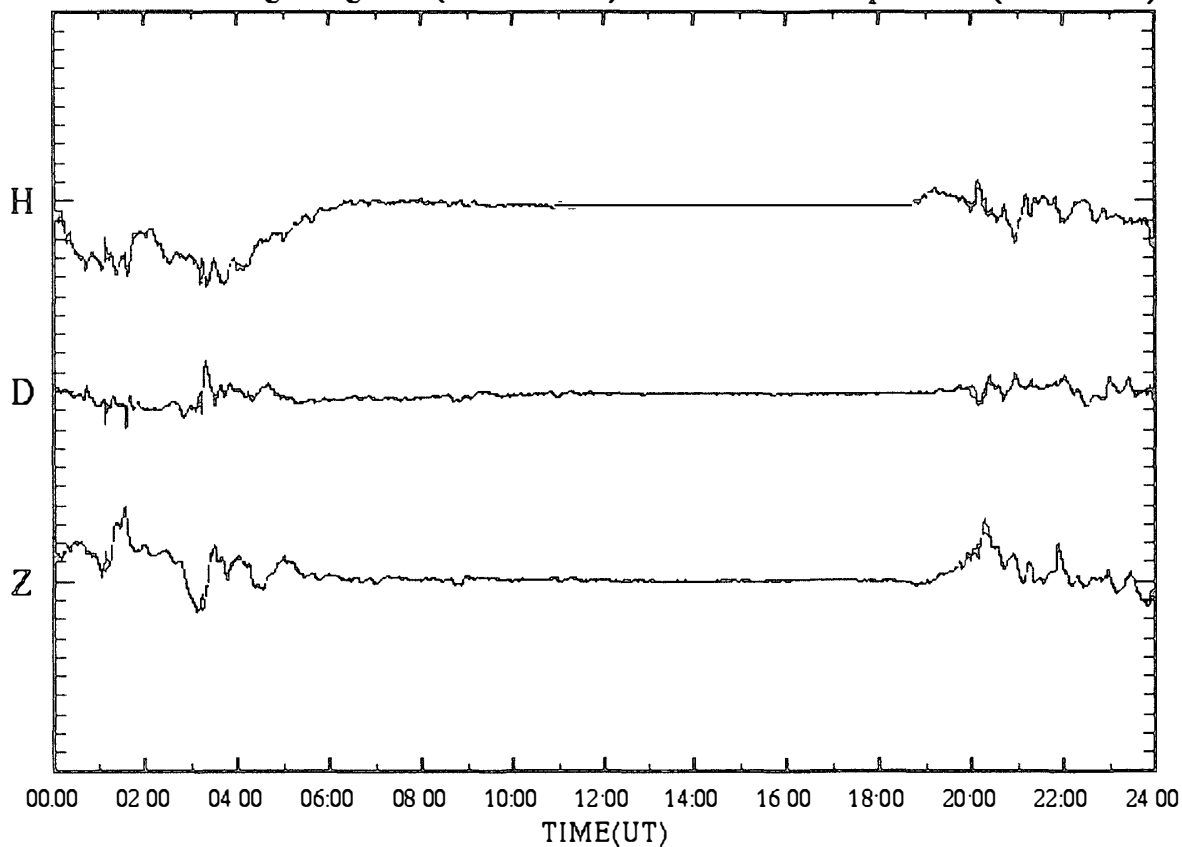

SYOWA magnetogram (100 nT/div)

01 May 1997 (DAY:121)

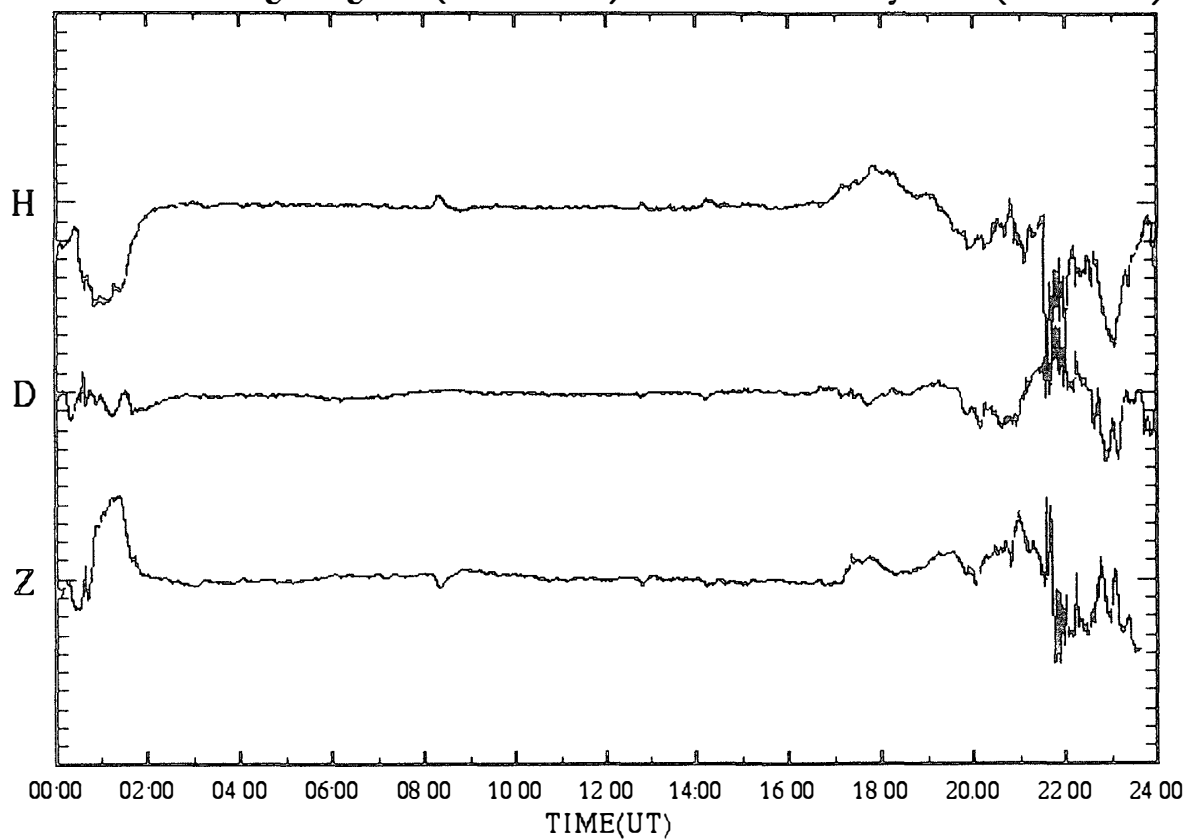

SYOWA magnetogram (100 nT/div)

02 May 1997 (DAY:122)

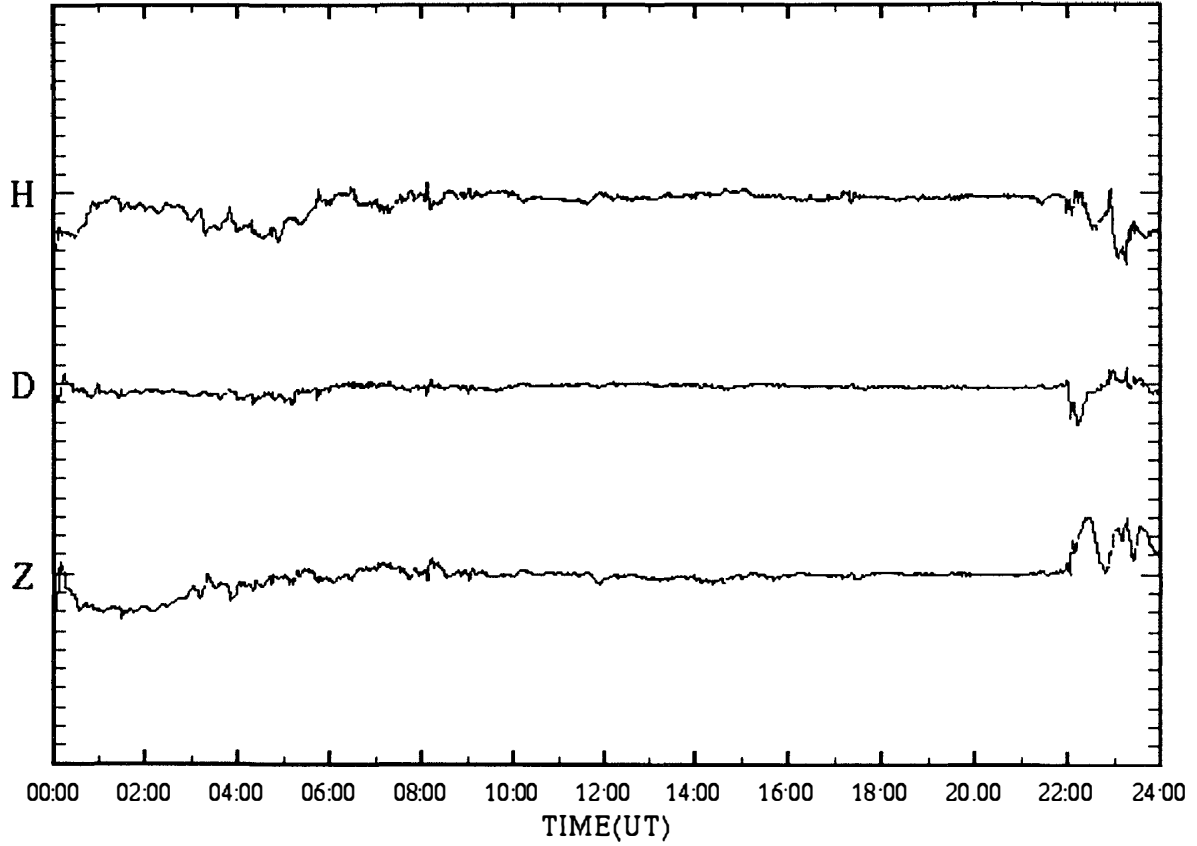

SYOWA magnetogram (100 nT/div)

03 May 1997 (DAY:123)

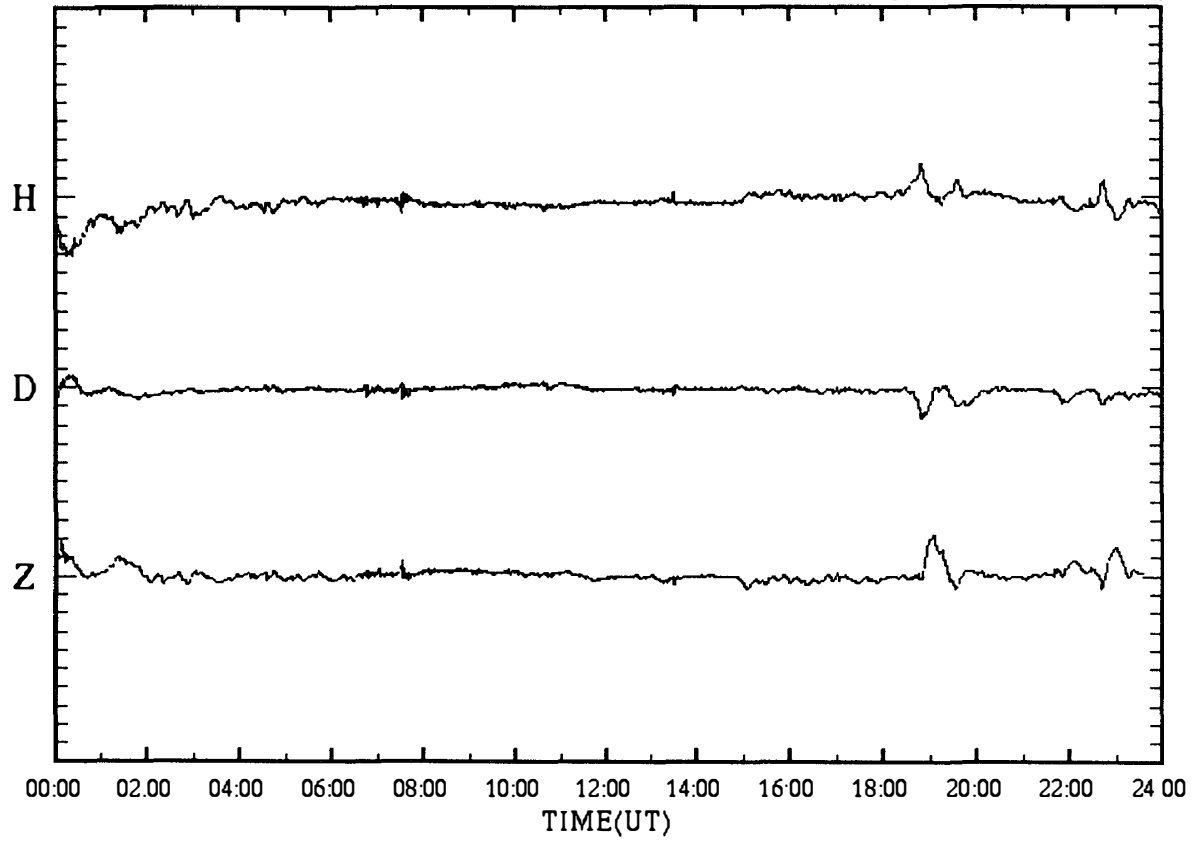

SYOWA magnetogram (100 nT/div)

04 May 1997 (DAY:124)

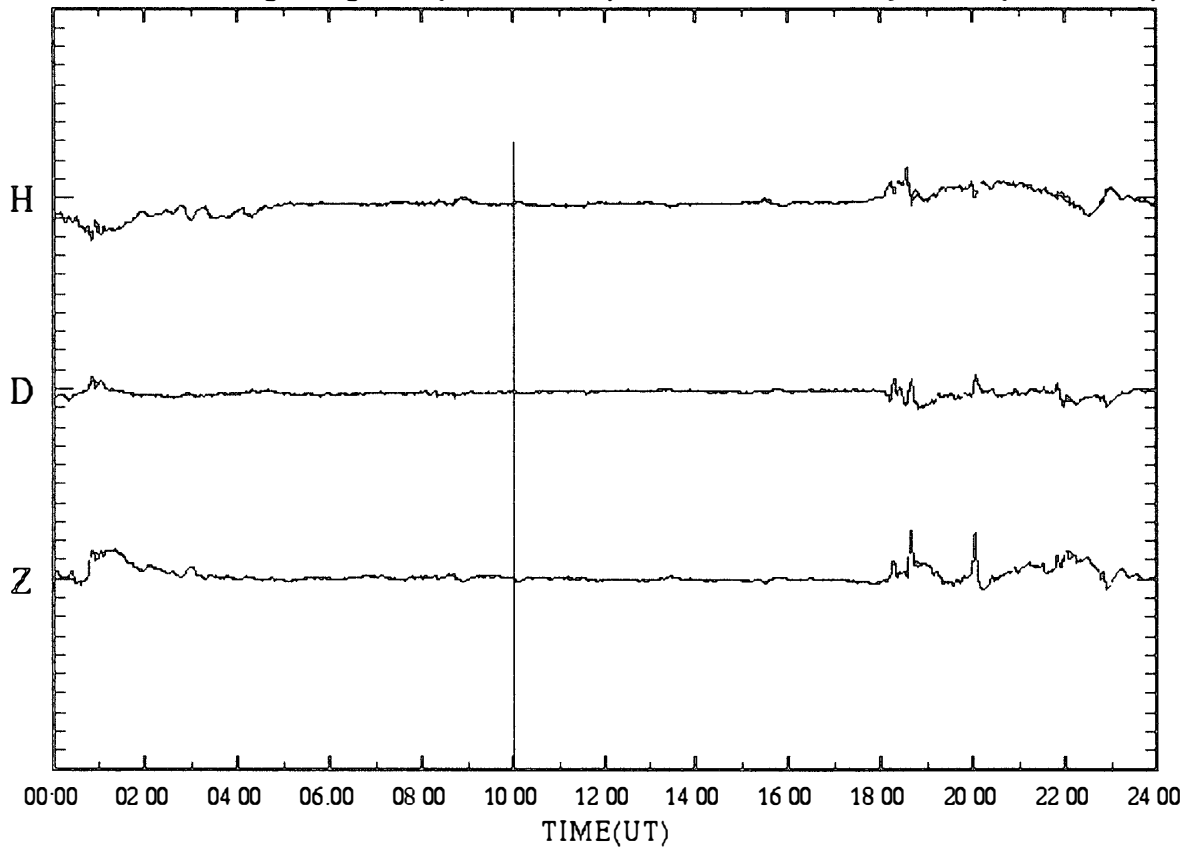

SYOWA magnetogram (100 nT/div)

05 May 1997 (DAY:125)

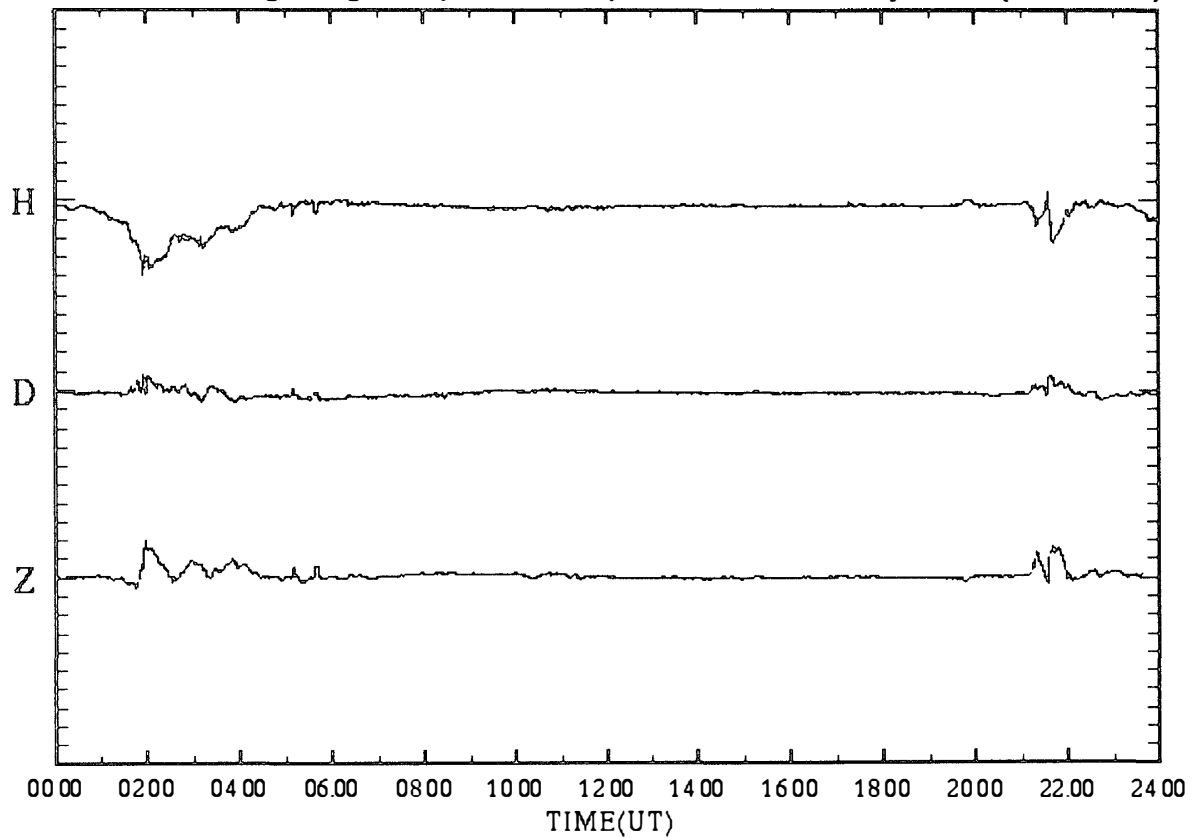

SYOWA magnetogram (100 nT/div)

06 May 1997 (DAY:126)

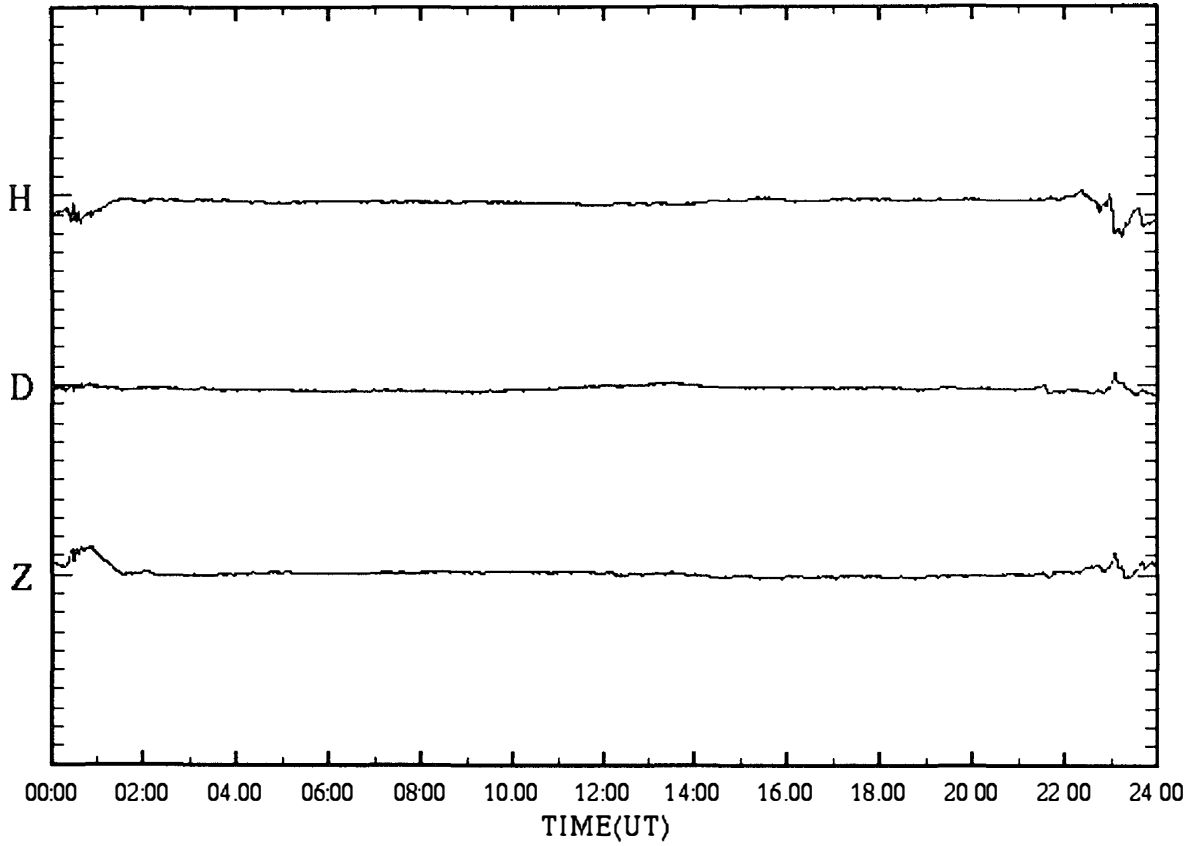

SYOWA magnetogram (100 nT/div)

07 May 1997 (DAY:127)

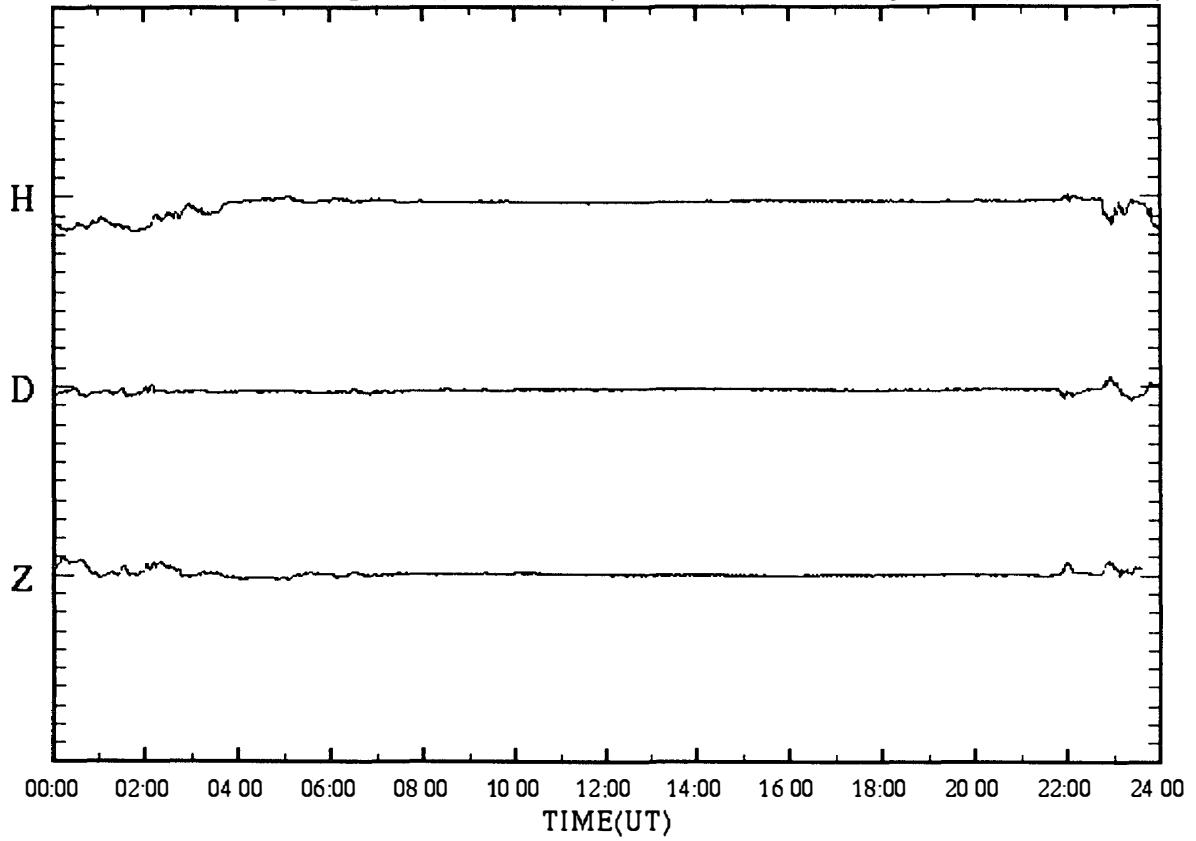

SYOWA magnetogram (100 nT/div)

08 May 1997 (DAY:128)

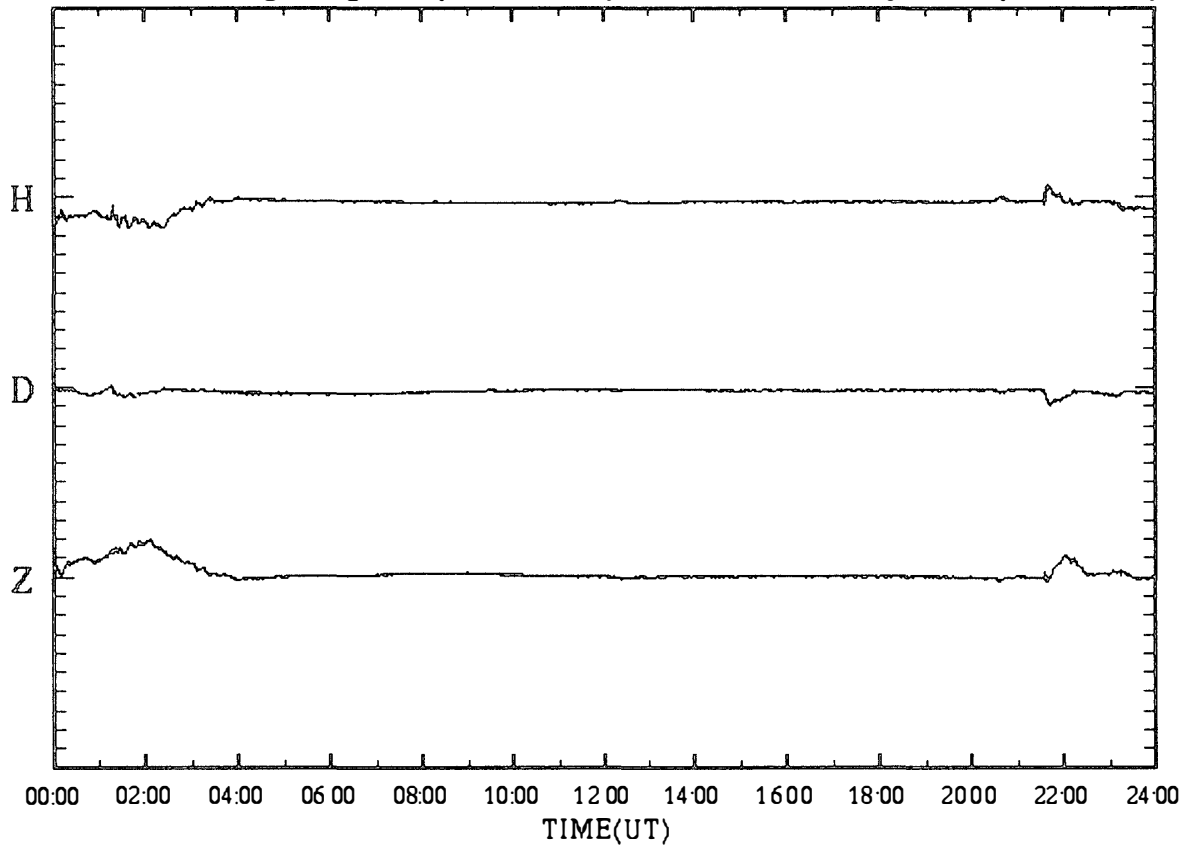

SYOWA magnetogram (100 nT/div)

09 May 1997 (DAY:129)

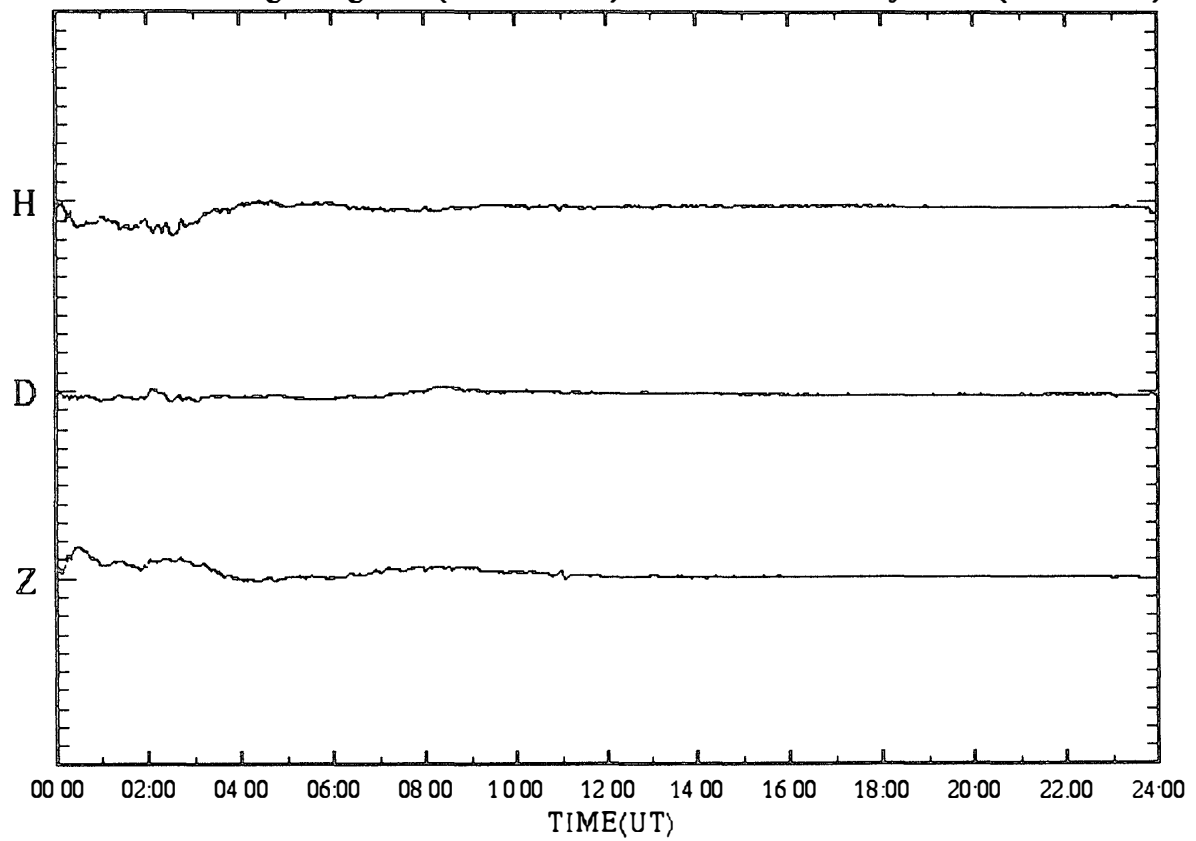

SYOWA magnetogram (100 nT/div)

10 May 1997 (DAY:130)

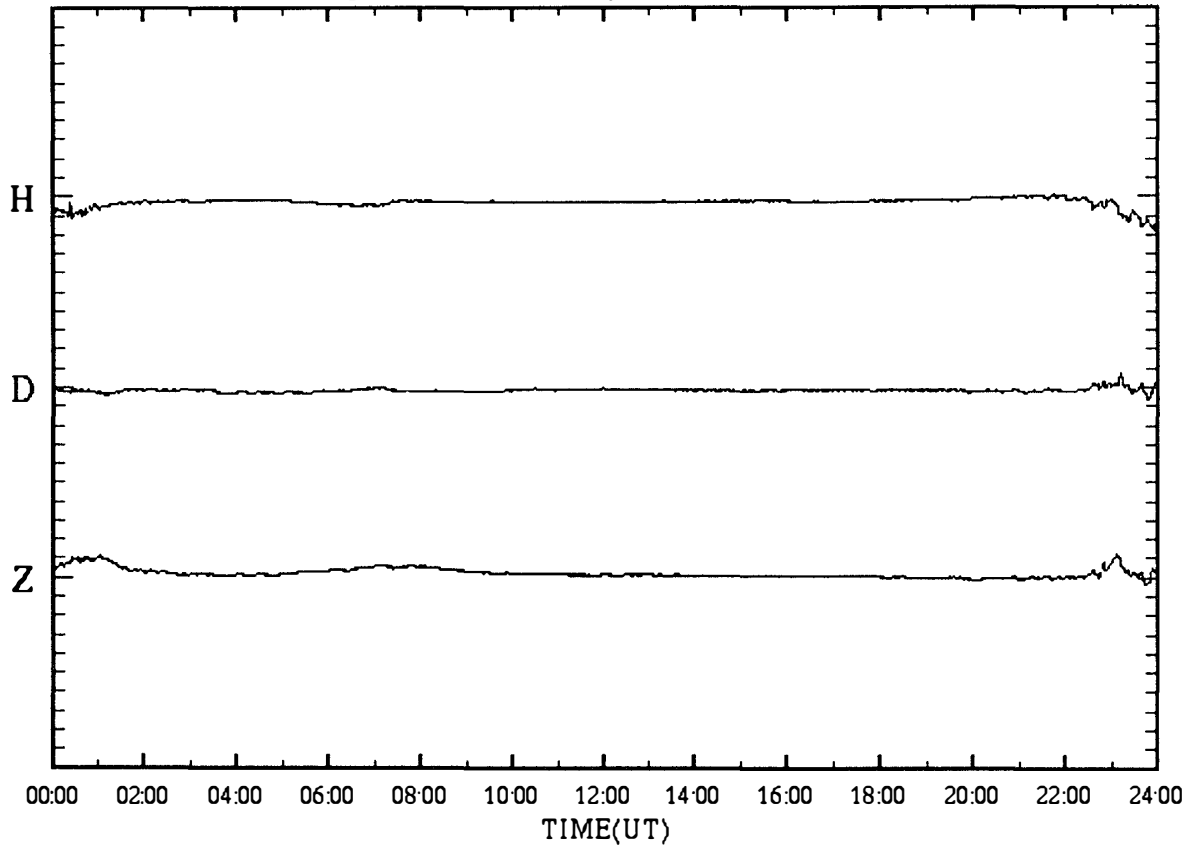

SYOWA magnetogram (100 nT/div)

11 May 1997 (DAY:131)

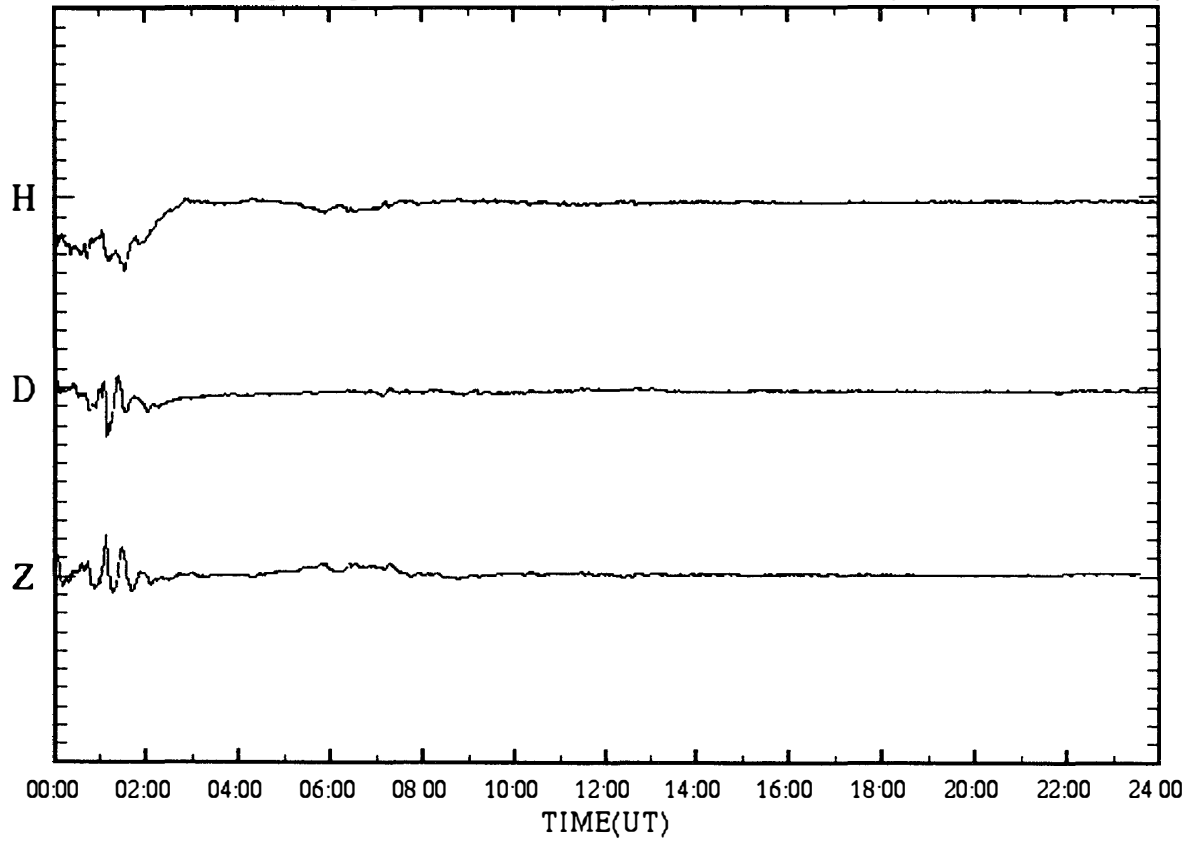

SYOWA magnetogram (100 nT/div)

12 May 1997 (DAY:132)

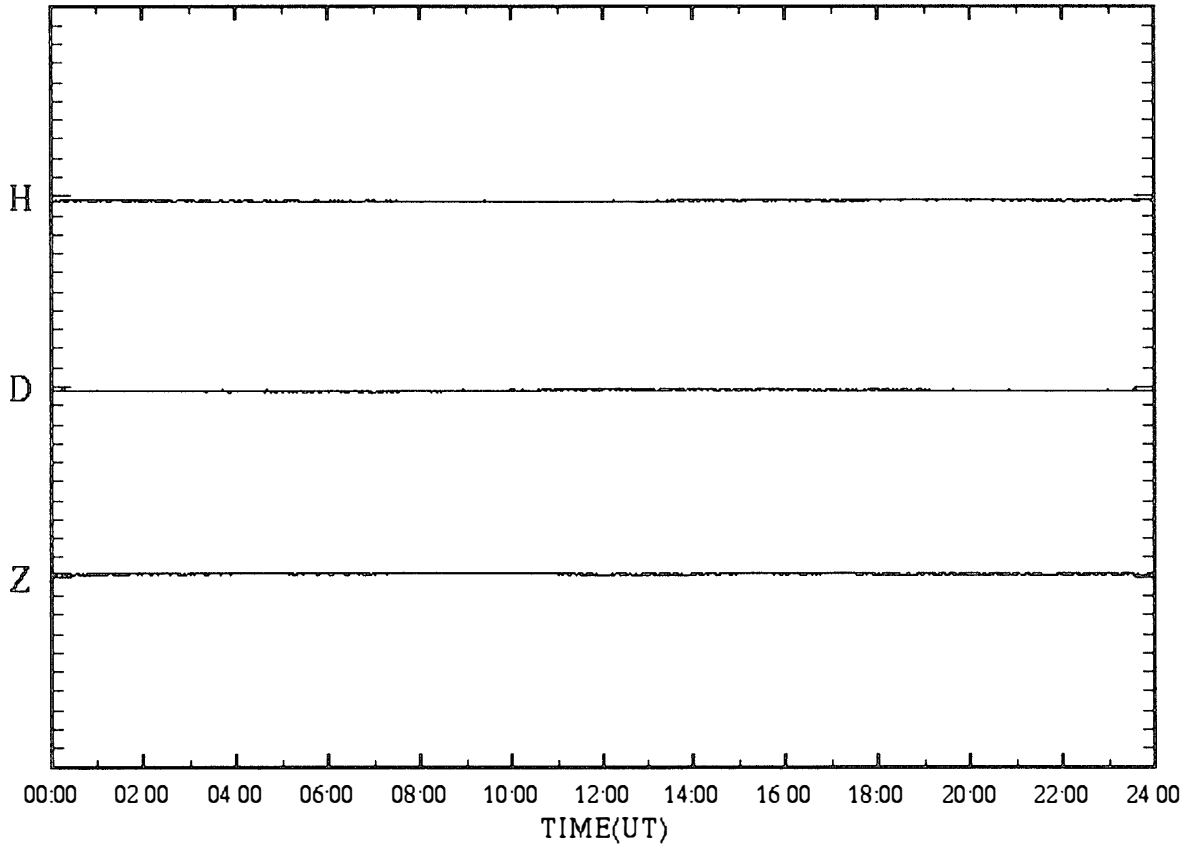

SYOWA magnetogram (100 nT/div)

13 May 1997 (DAY:133)

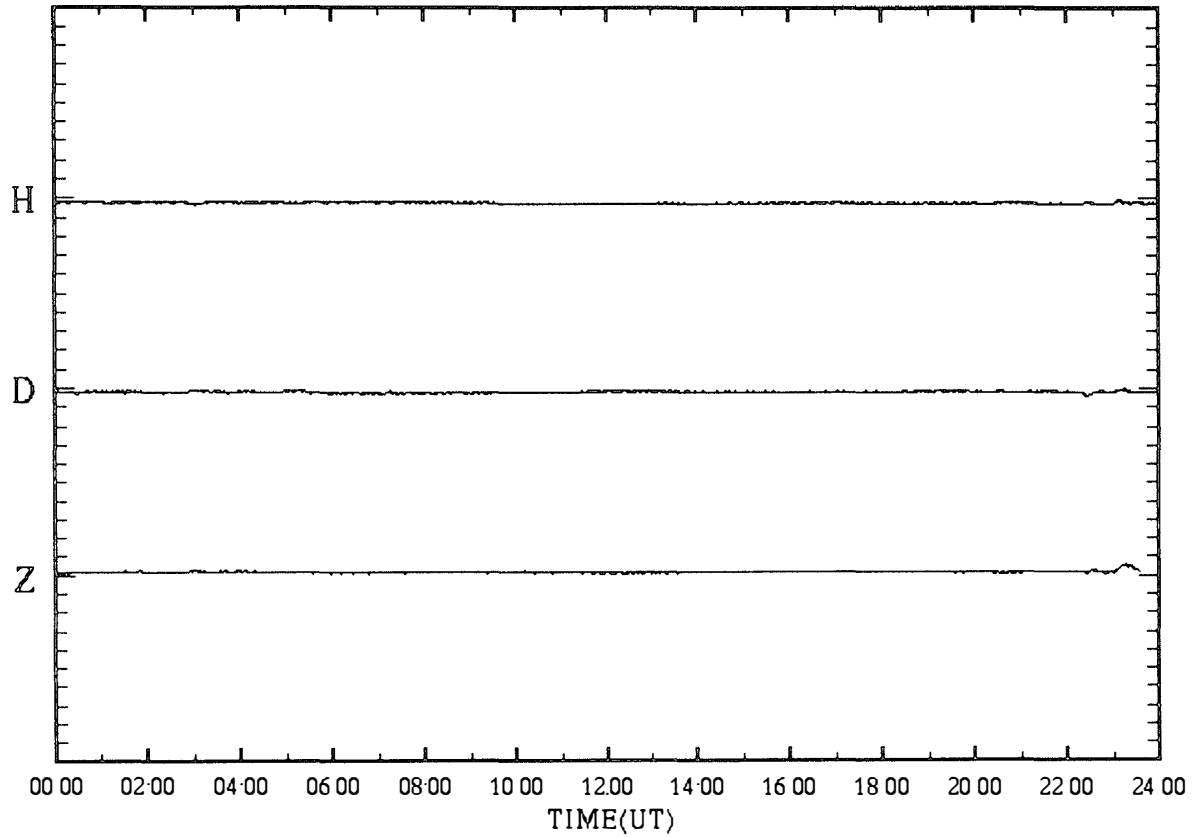



SYOWA magnetogram (100 nT/div)

14 May 1997 (DAY:134)

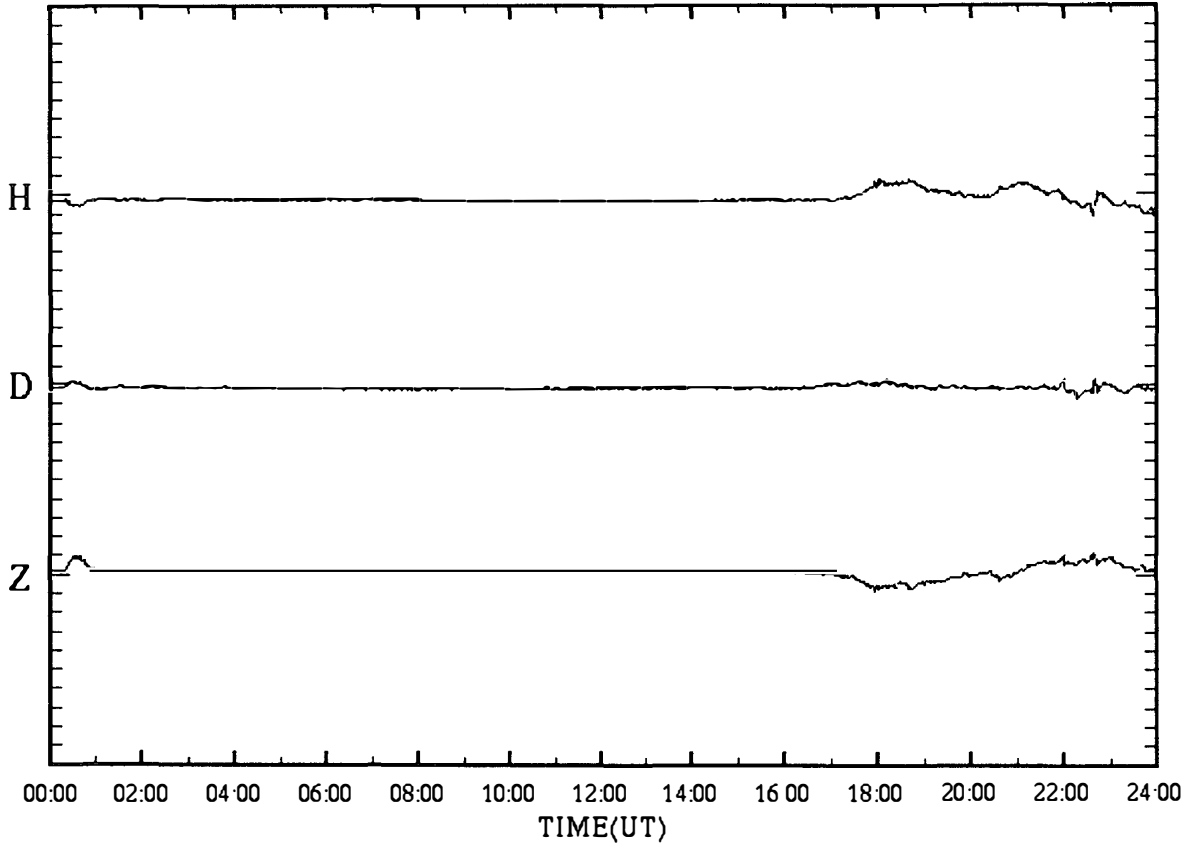

SYOWA magnetogram (100 nT/div)

15 May 1997 (DAY:135)

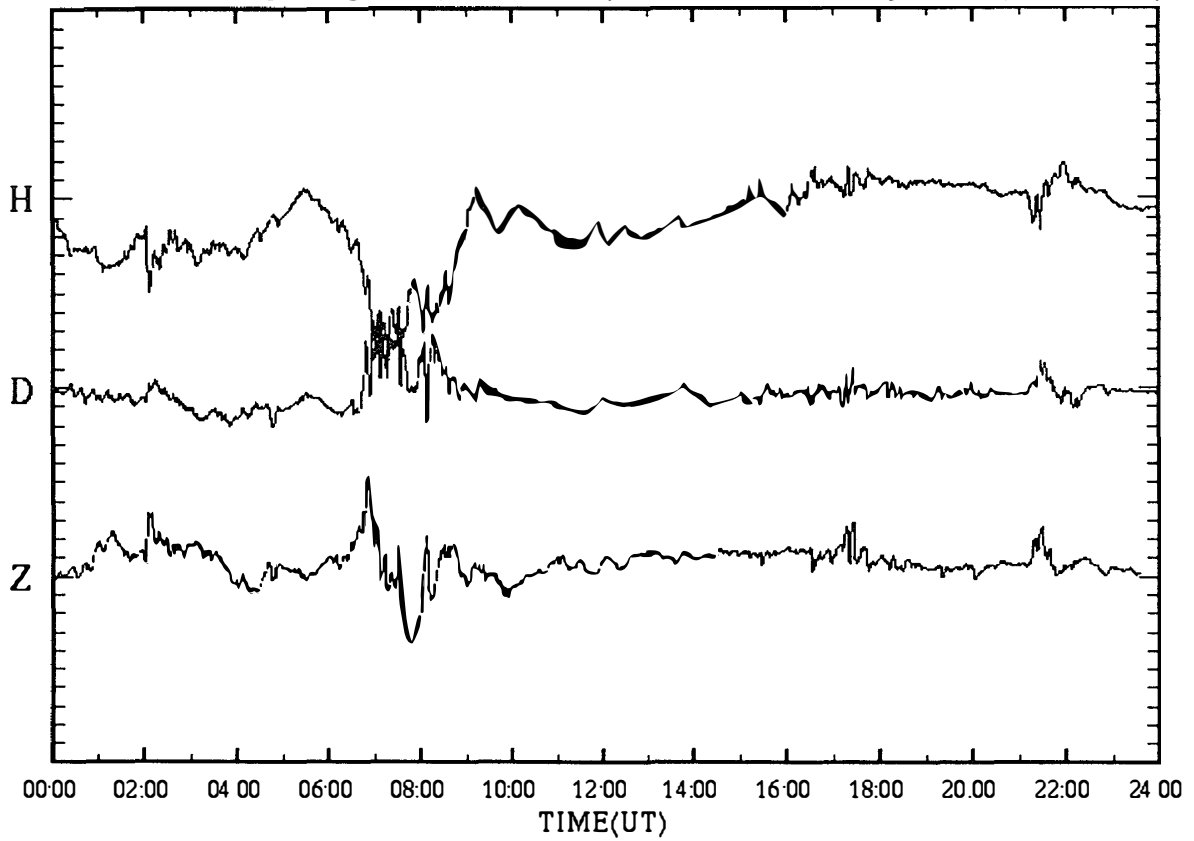

SYOWA magnetogram (100 nT/div)

16 May 1997 (DAY:136)

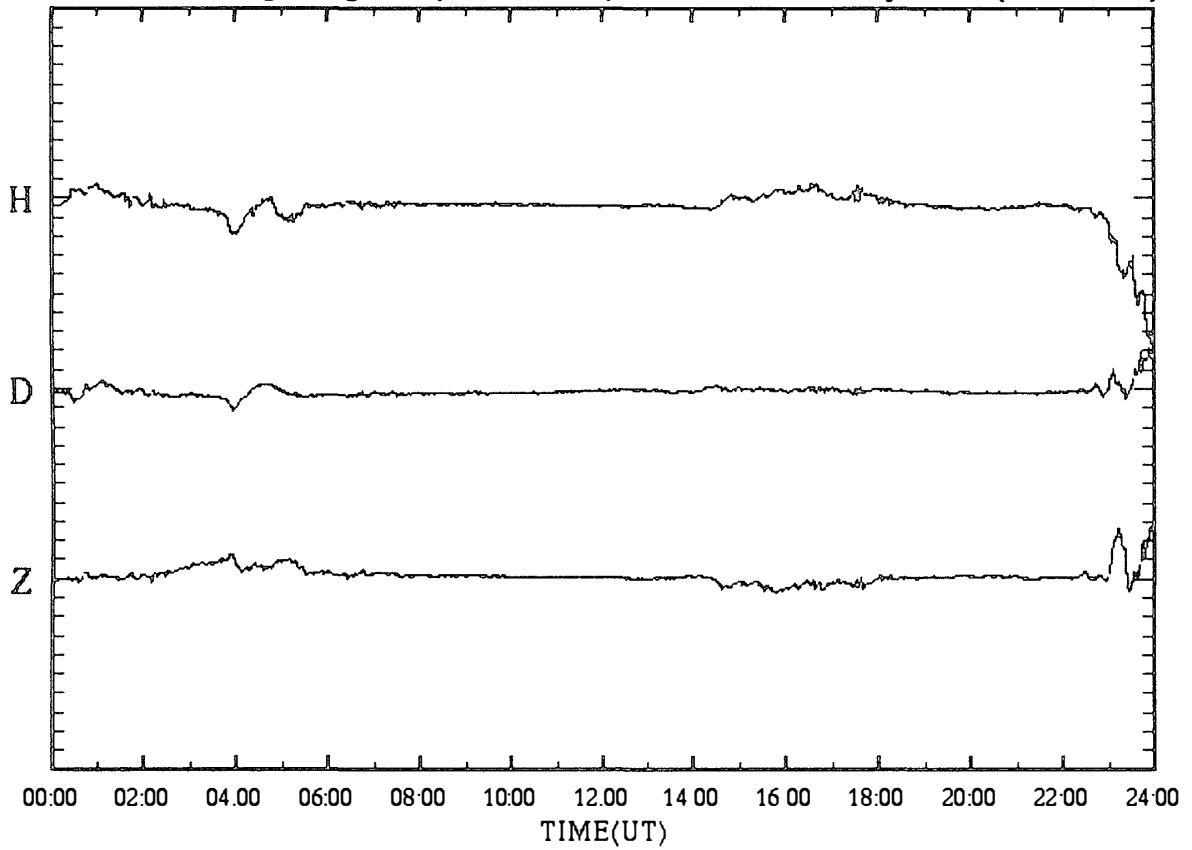

SYOWA magnetogram (100 nT/div)

17 May 1997 (DAY:137)

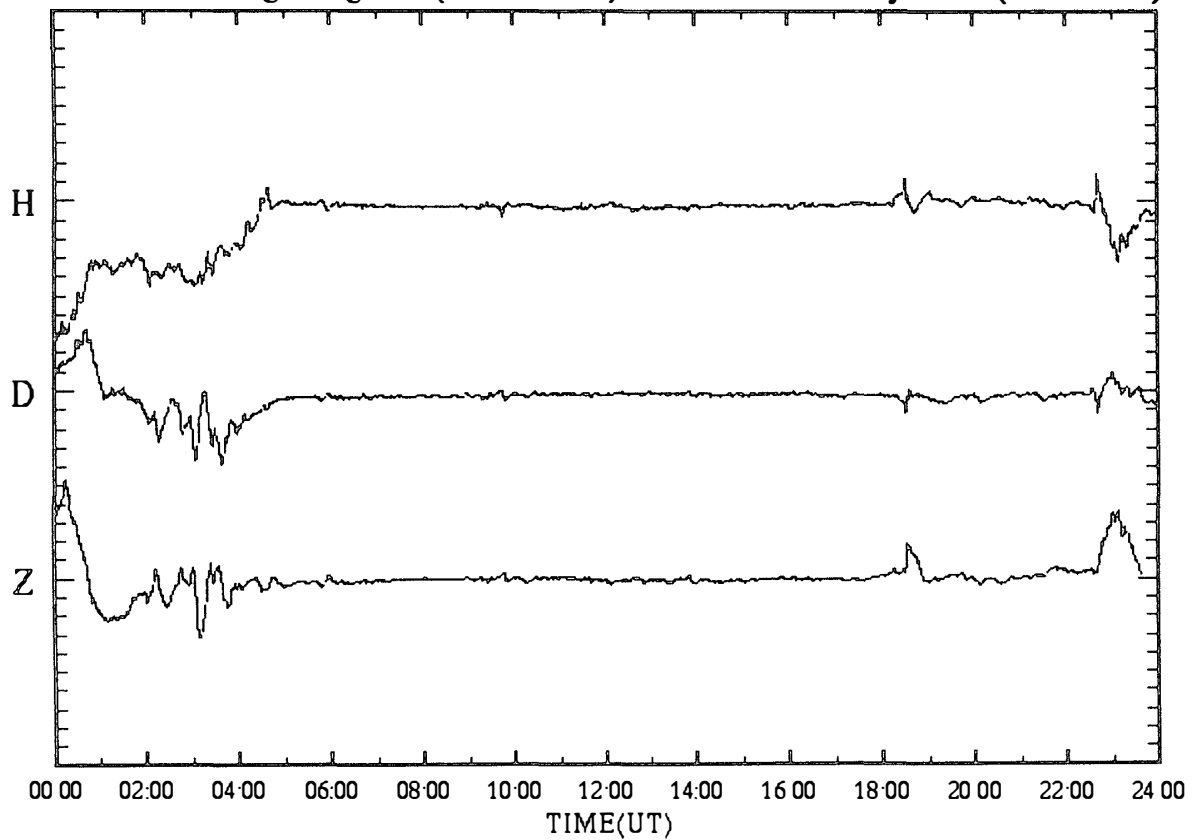

SYOWA magnetogram (100 nT/div)

18 May 1997 (DAY:138)

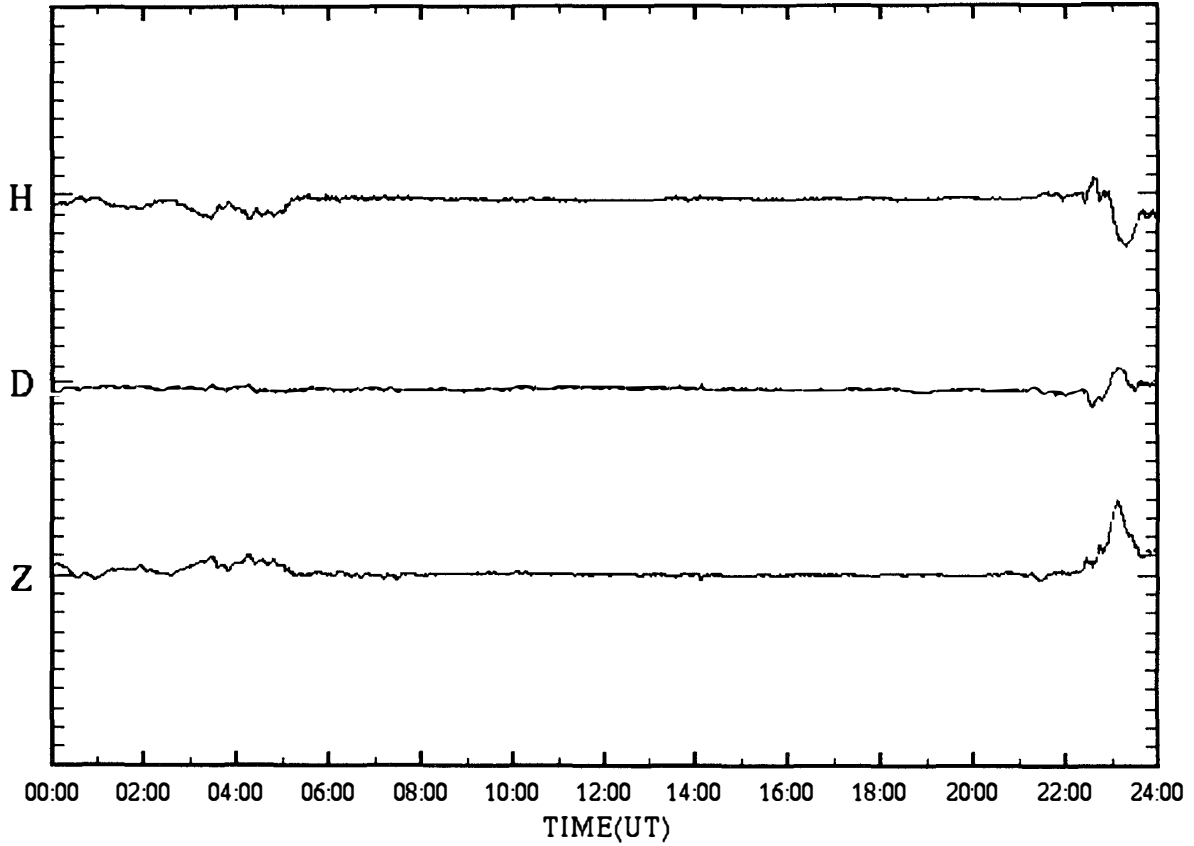

SYOWA magnetogram (100 nT/div)

19 May 1997 (DAY:139)

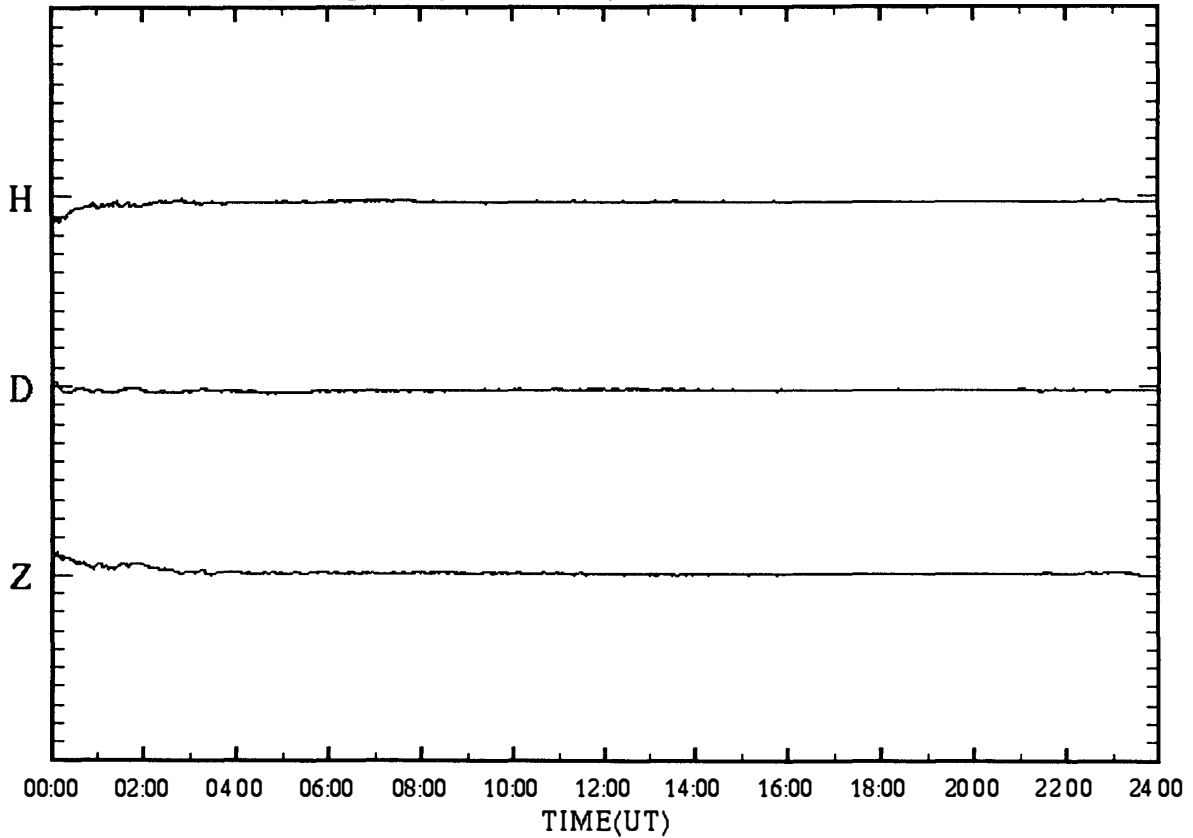

SYOWA magnetogram (100 nT/div)

20 May 1997 (DAY:140)

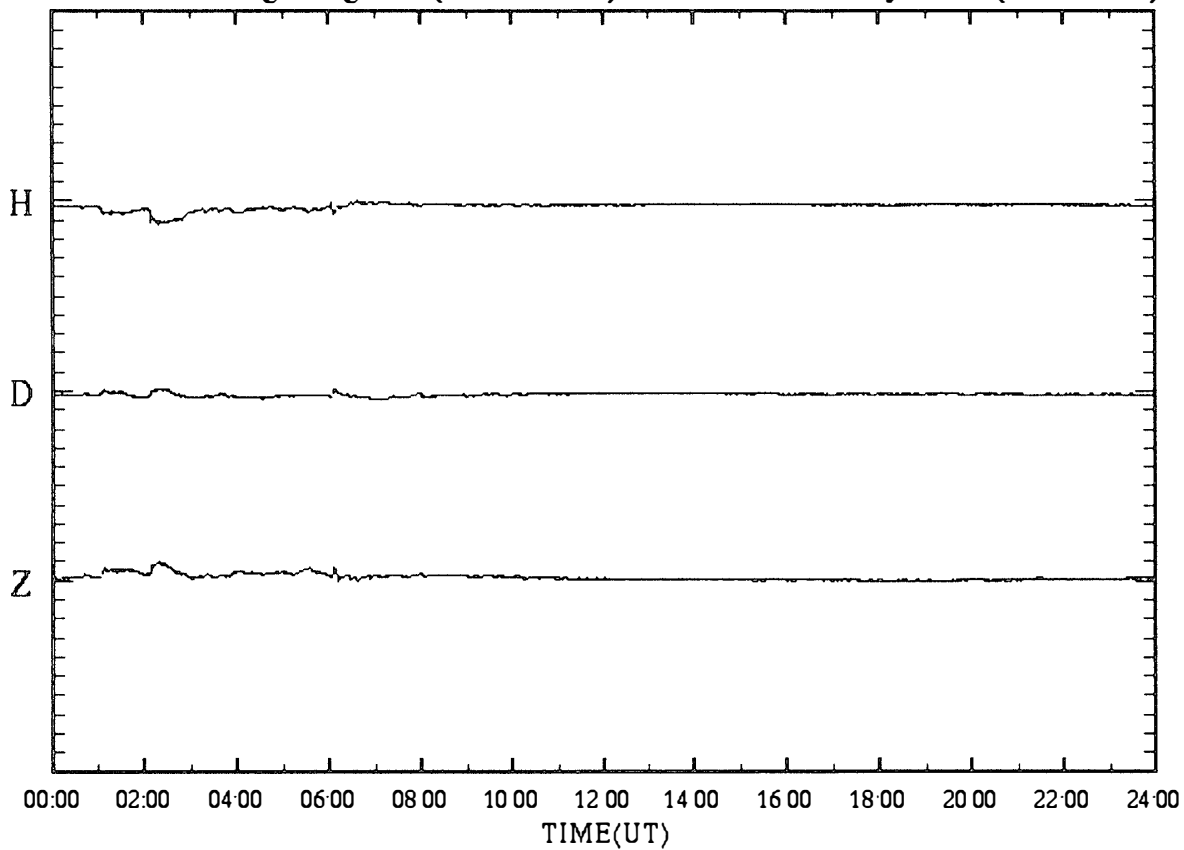

SYOWA magnetogram (100 nT/div)

21 May 1997 (DAY:141)

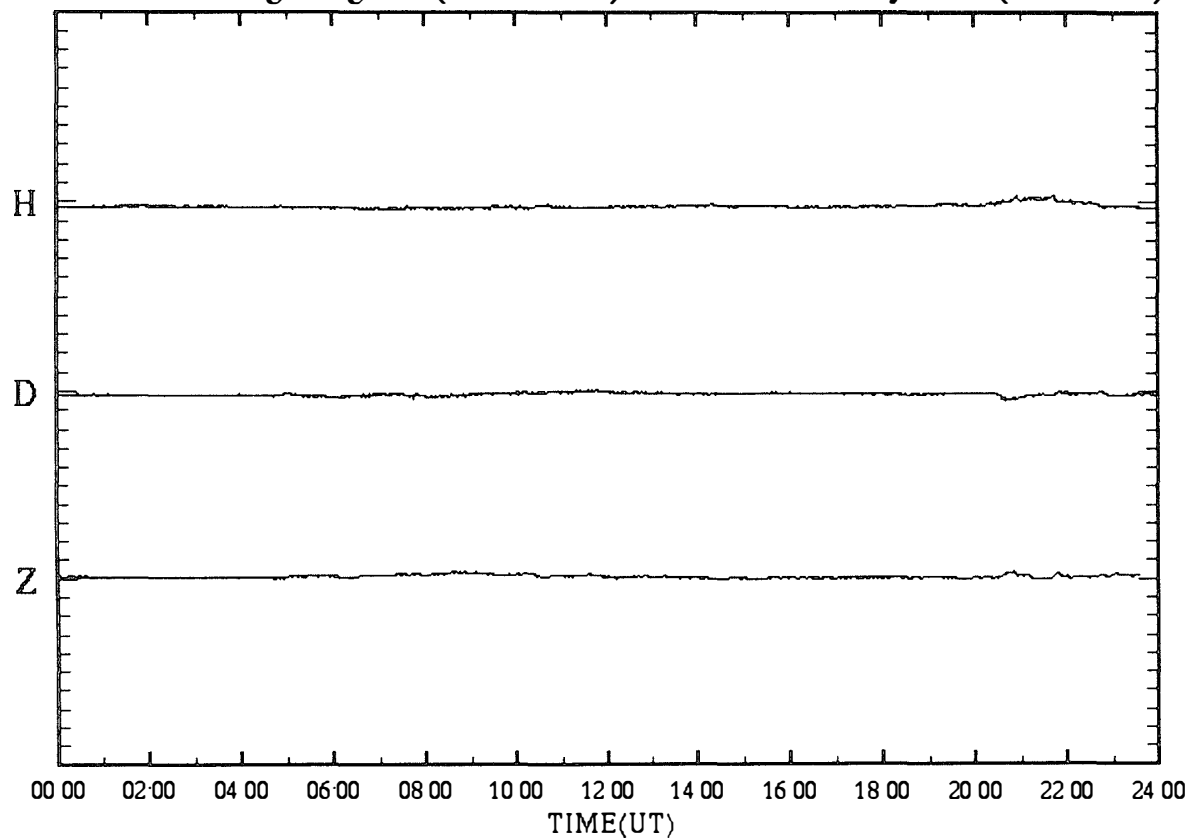

SYOWA magnetogram (100 nT/div)

22 May 1997 (DAY:142)

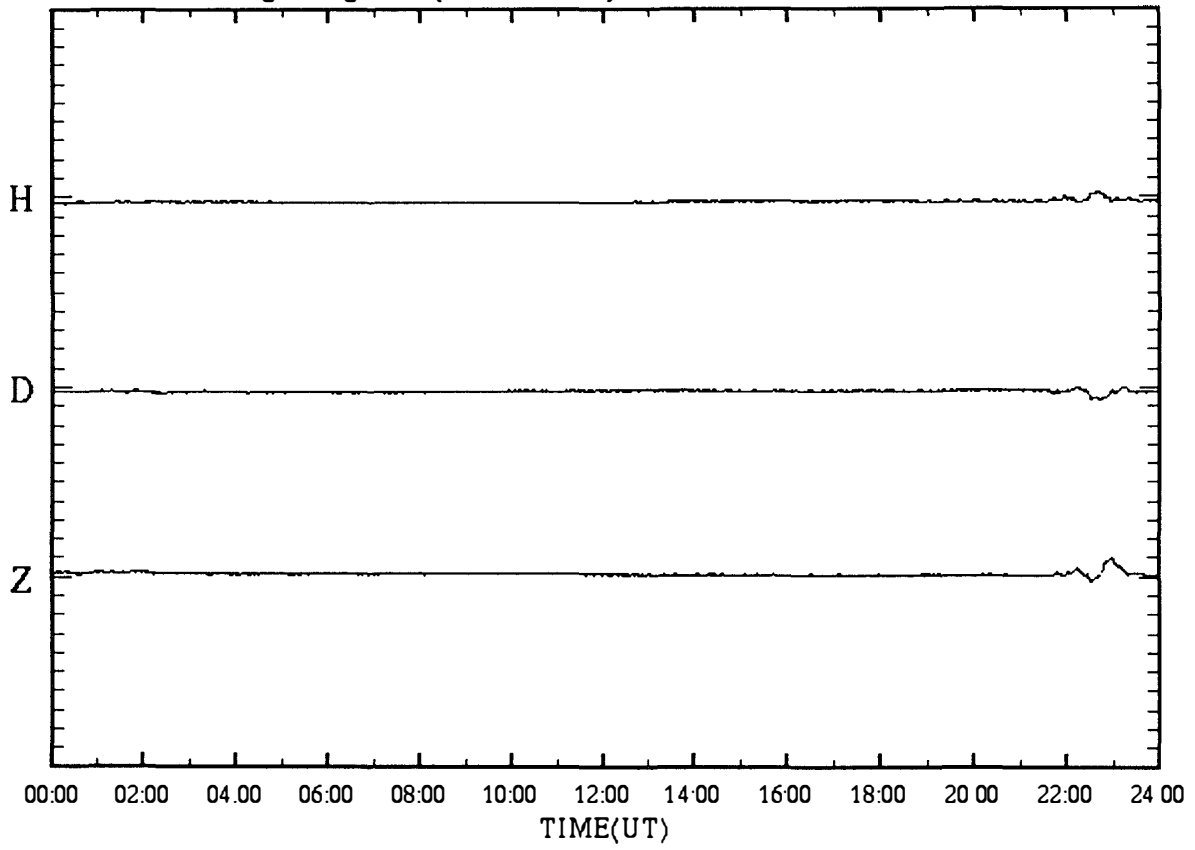

SYOWA magnetogram (100 nT/div)

23 May 1997 (DAY:143)

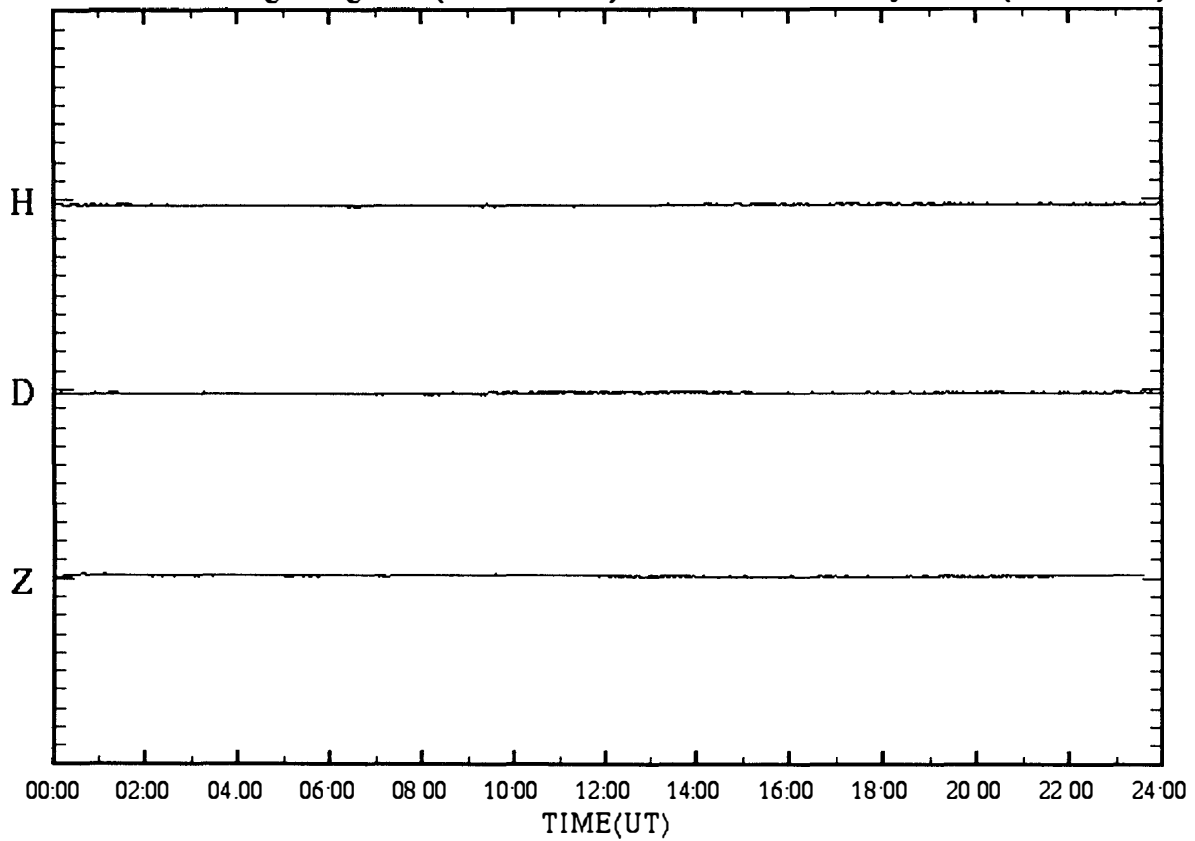

SYOWA magnetogram (100 nT/div)

24 May 1997 (DAY:144)

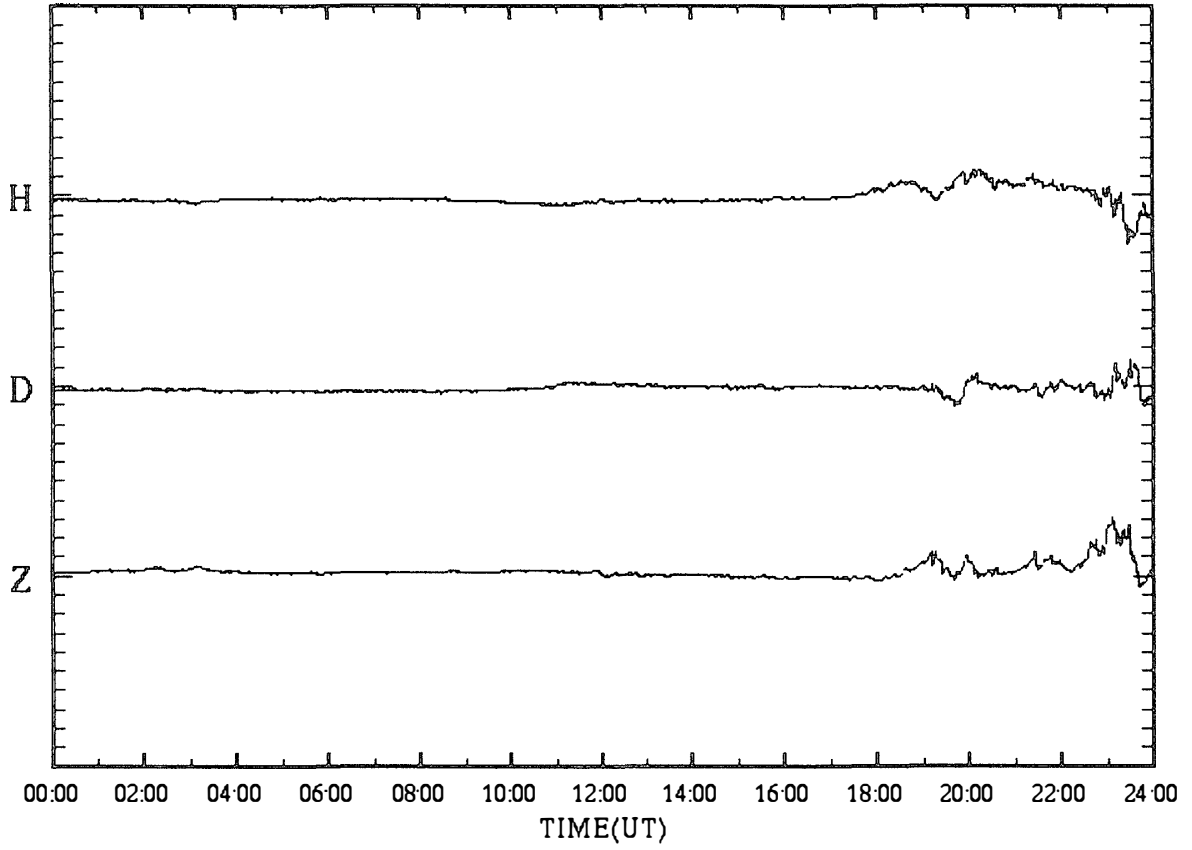

SYOWA magnetogram (100 nT/div)

25 May 1997 (DAY:145)

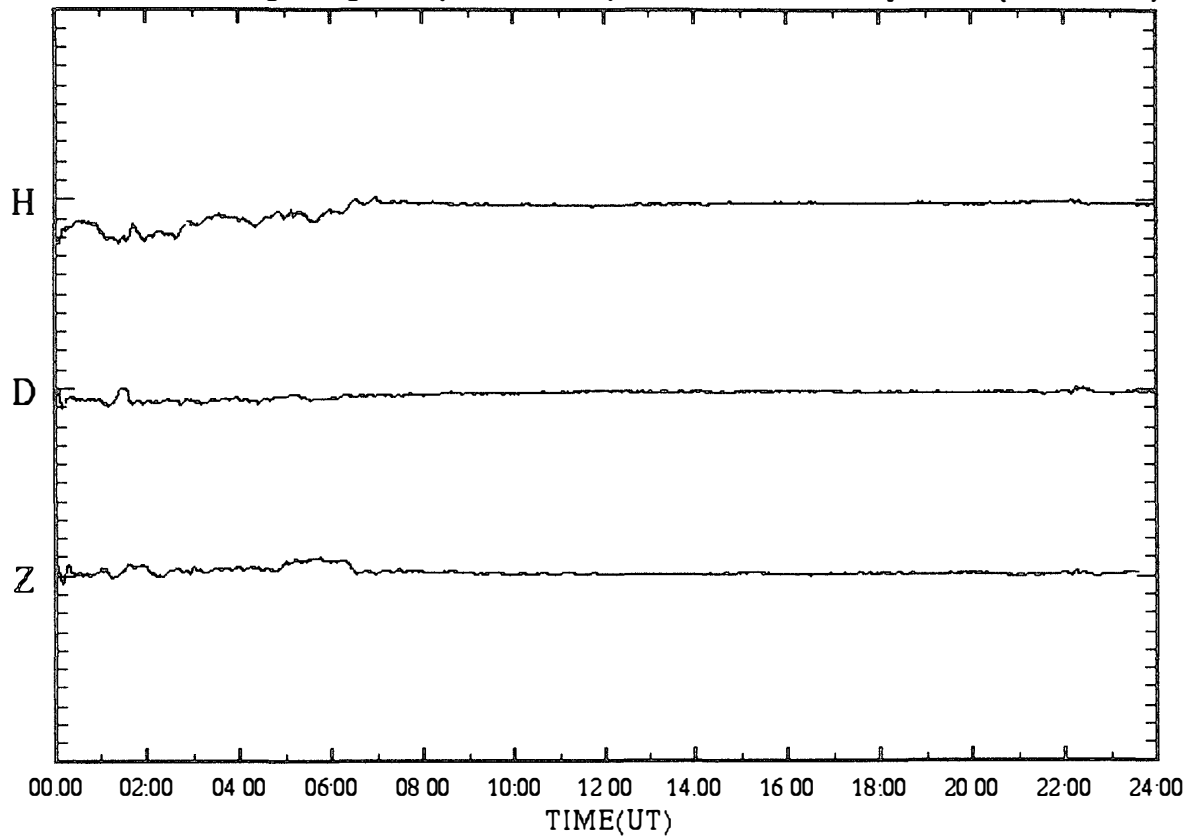

SYOWA magnetogram (100 nT/div)

26 May 1997 (DAY:146)

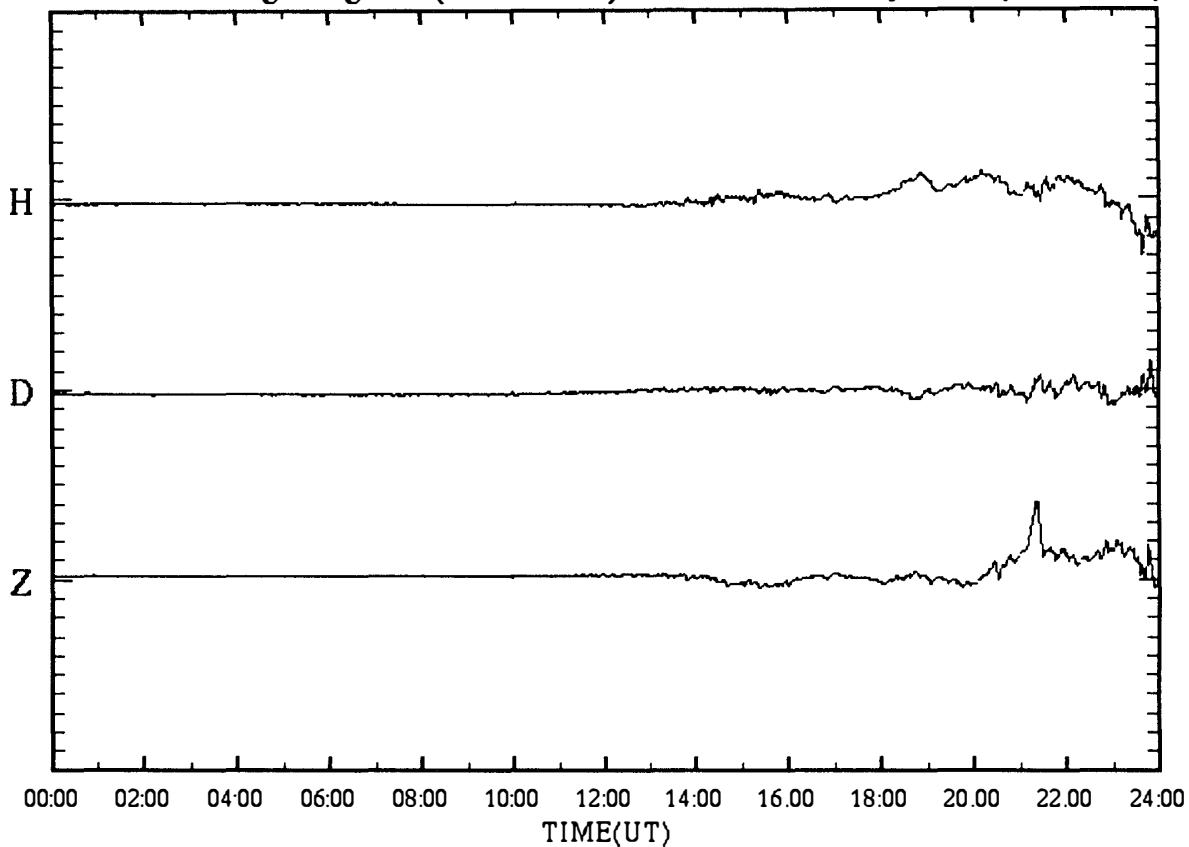

SYOWA magnetogram (100 nT/div)

27 May 1997 (DAY:147)

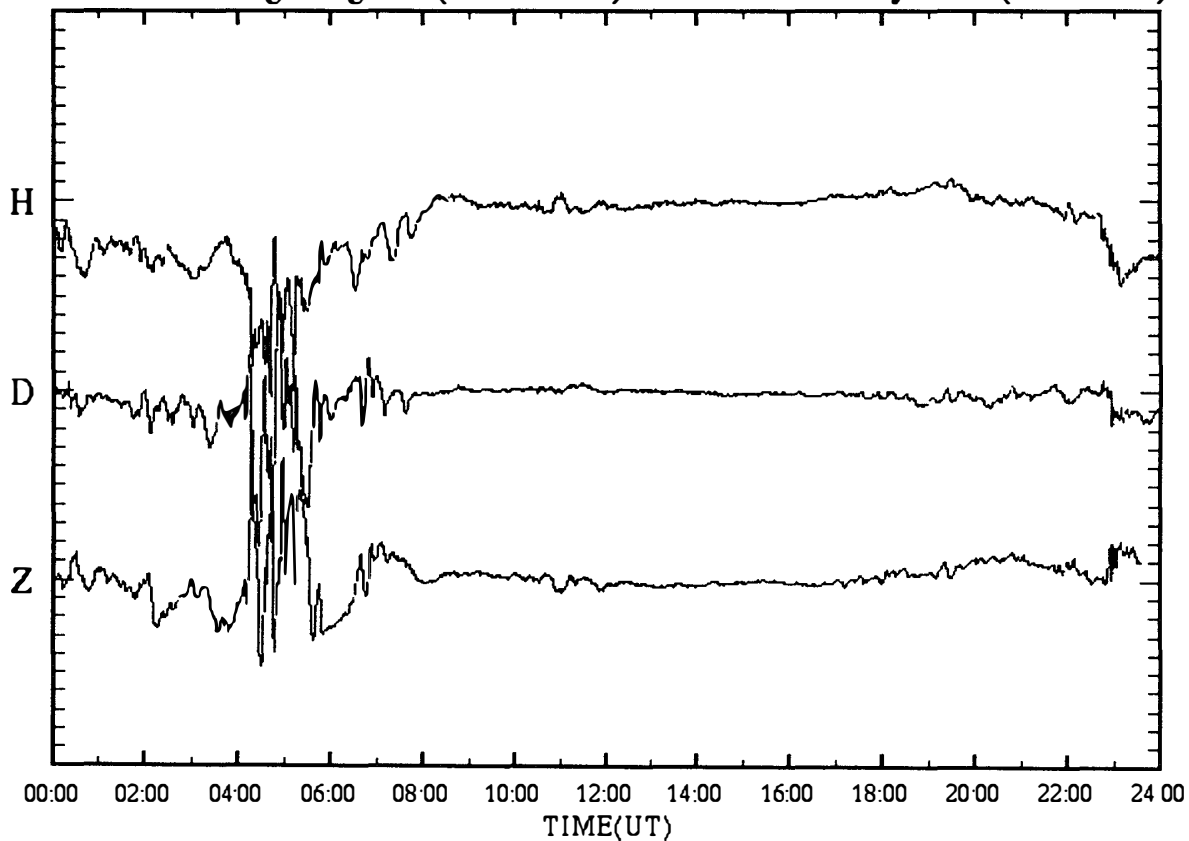

SYOWA magnetogram (100 nT/div)

28 May 1997 (DAY:148)

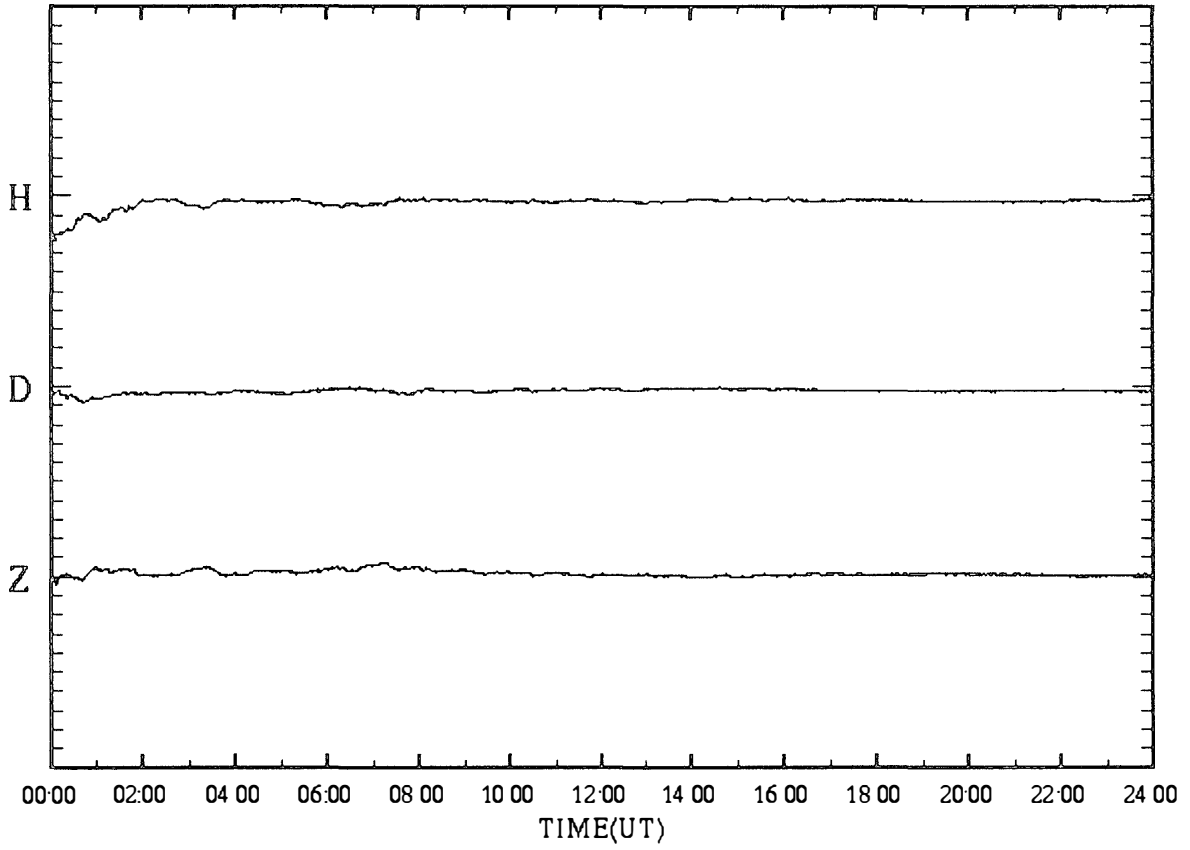

SYOWA magnetogram (100 nT/div)

29 May 1997 (DAY:149)

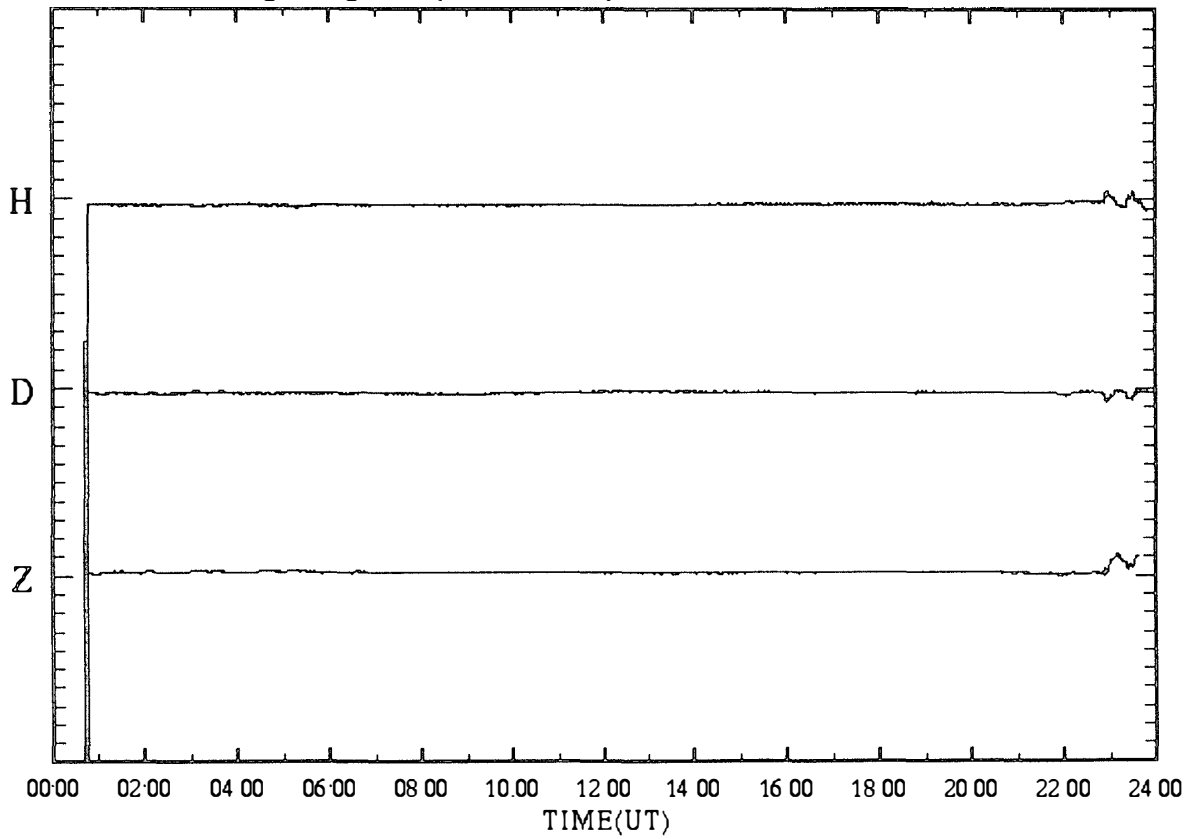



SYOWA magnetogram (100 nT/div)

30 May 1997 (DAY:150)

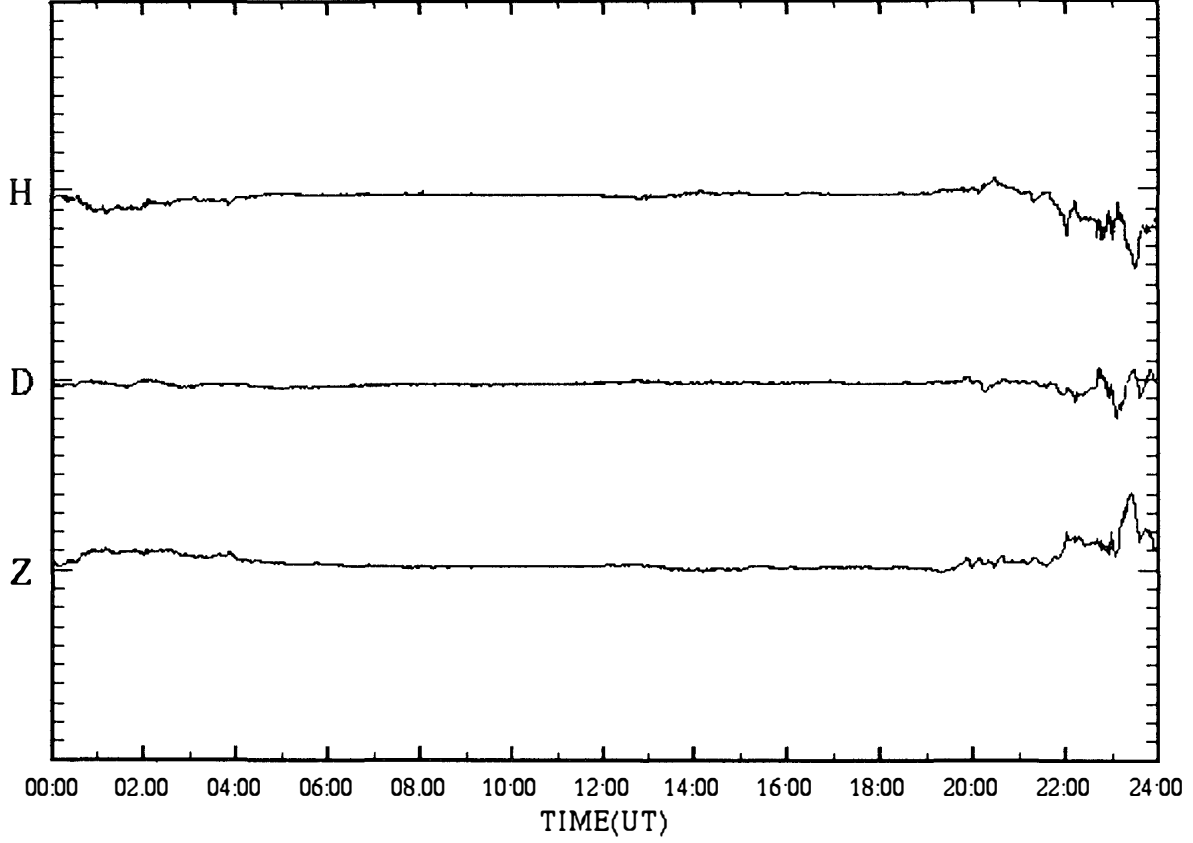

SYOWA magnetogram (100 nT/div)

31 May 1997 (DAY:151)

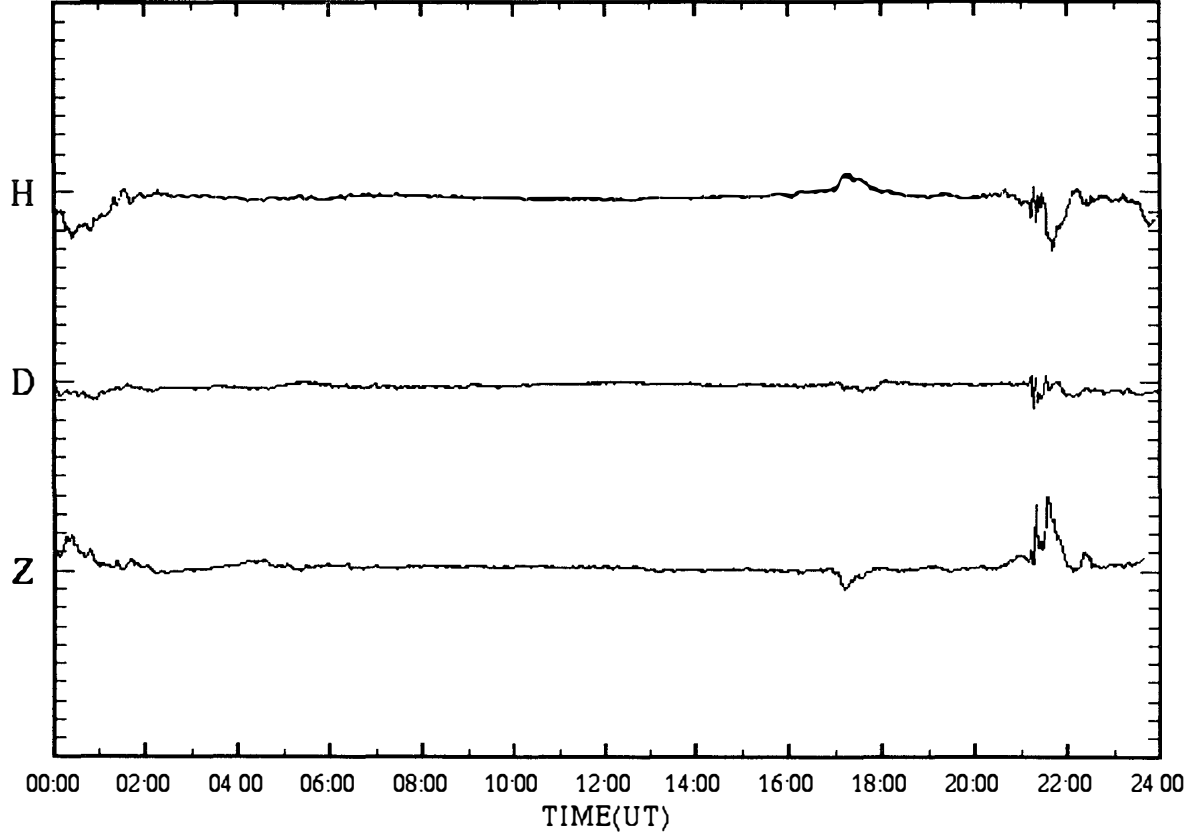

SYOWA magnetogram (100 nT/div)

01 Jun.1997 (DAY:152)

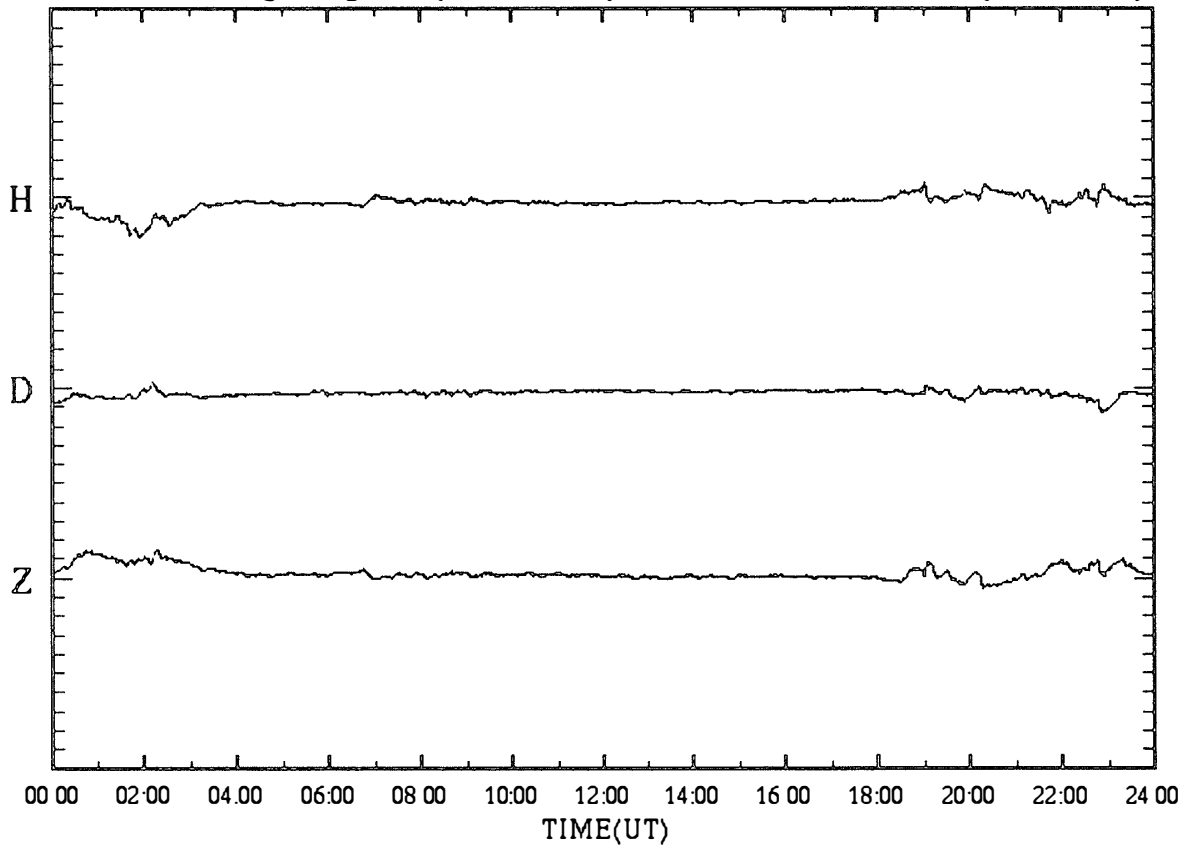

SYOWA magnetogram (100 nT/div)

02 Jun.1997 (DAY:153)

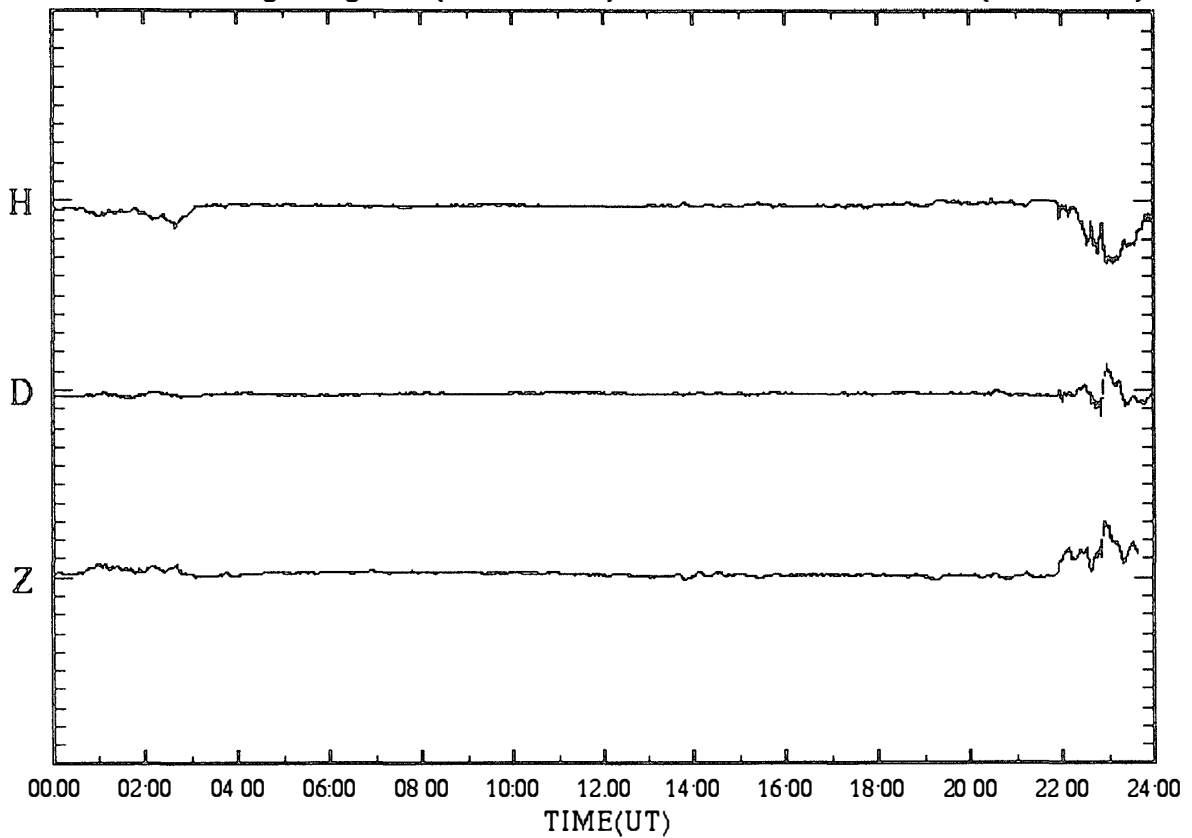

SYOWA magnetogram (100 nT/div)

03 Jun.1997 (DAY:154)

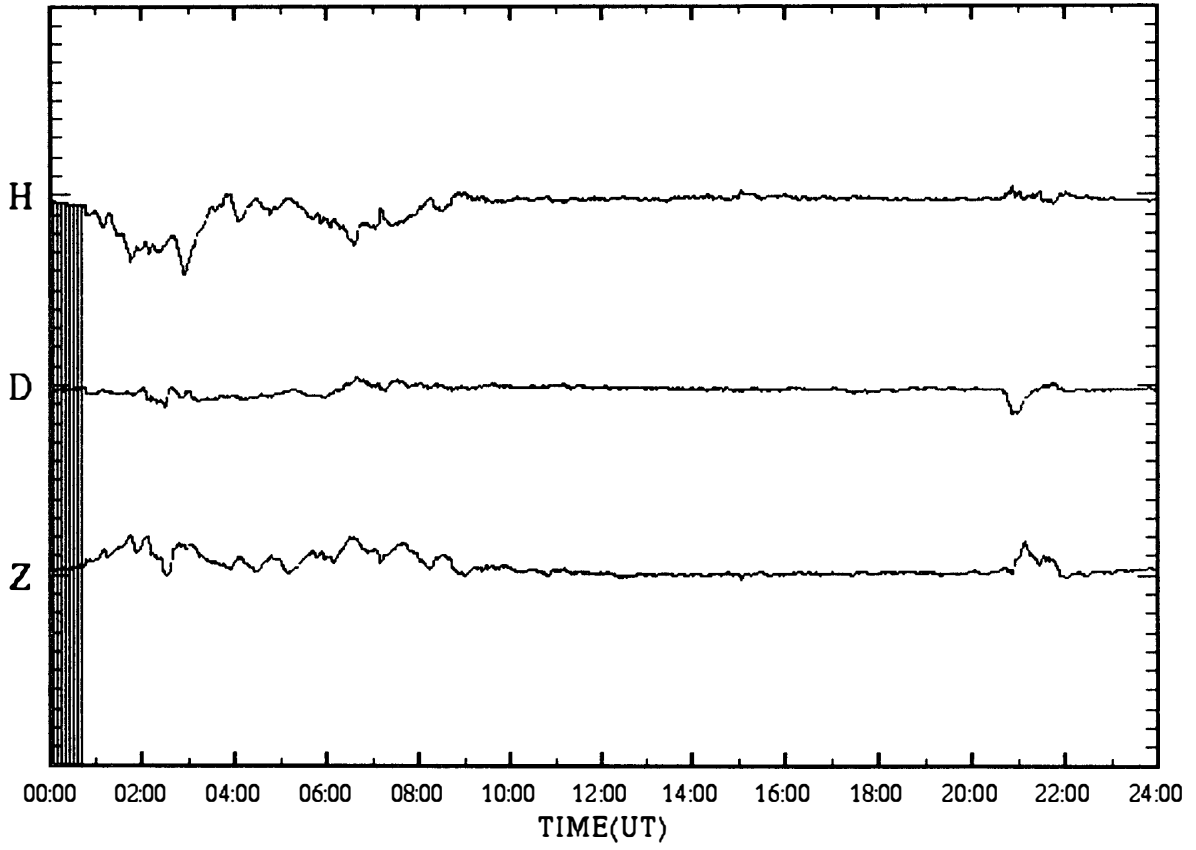

SYOWA magnetogram (100 nT/div)

04 Jun.1997 (DAY:155)

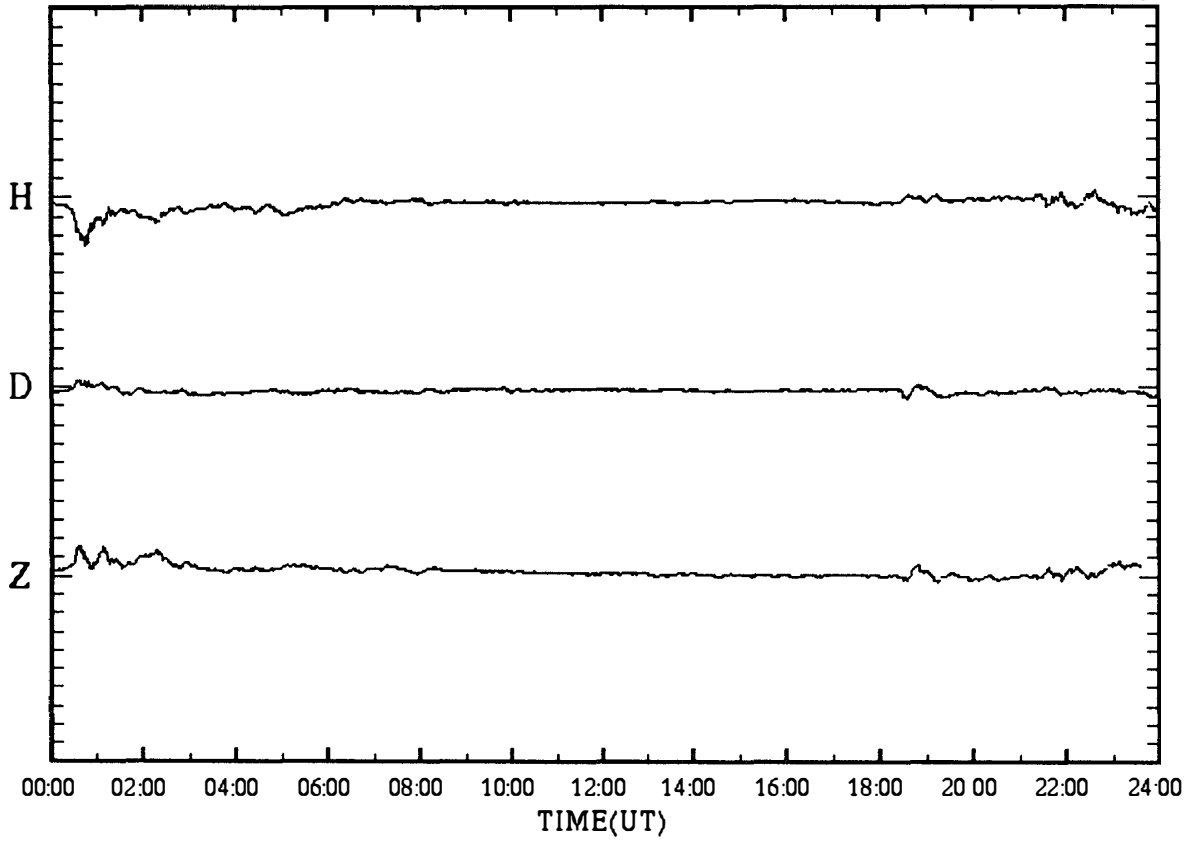

SYOWA magnetogram (100 nT/div)

05 Jun.1997 (DAY:156)

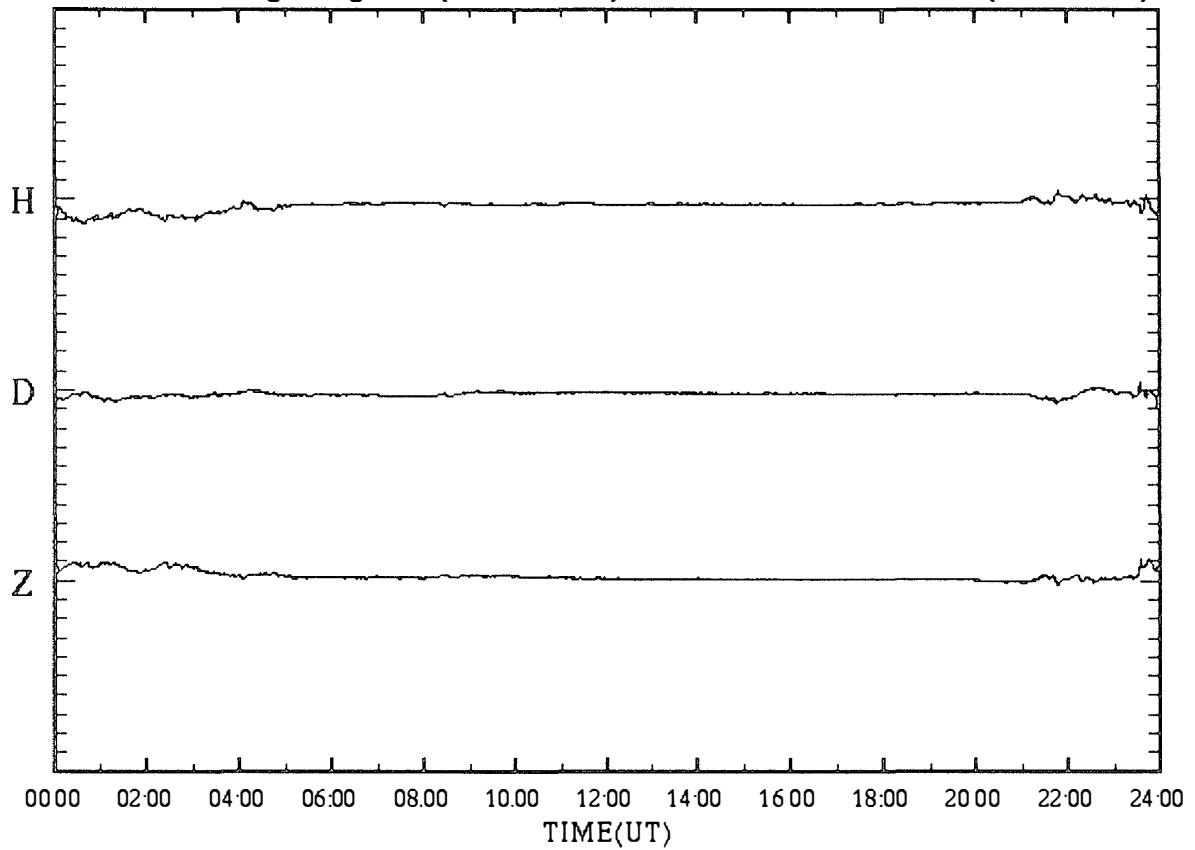

SYOWA magnetogram (100 nT/div)

06 Jun.1997 (DAY:157)

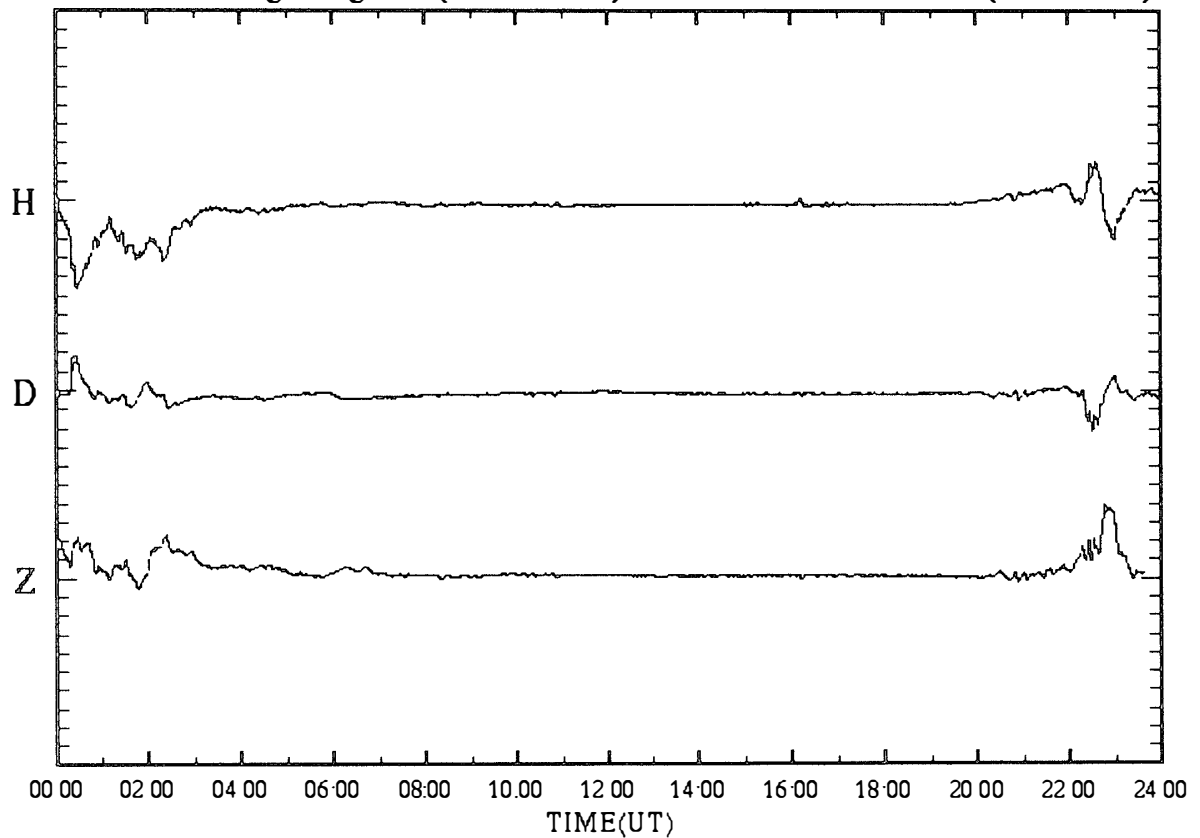

SYOWA magnetogram (100 nT/div)

07 Jun.1997 (DAY:158)

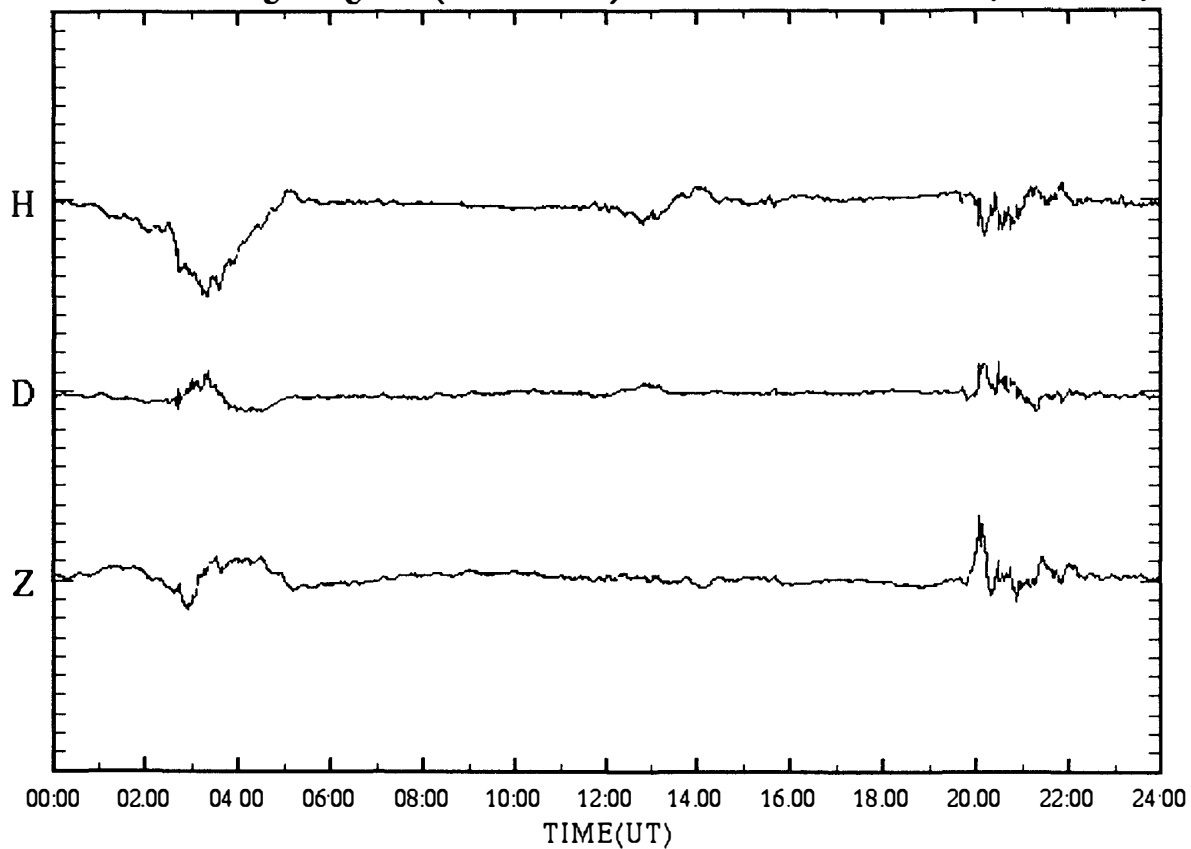

SYOWA magnetogram (100 nT/div)

08 Jun.1997 (DAY:159)

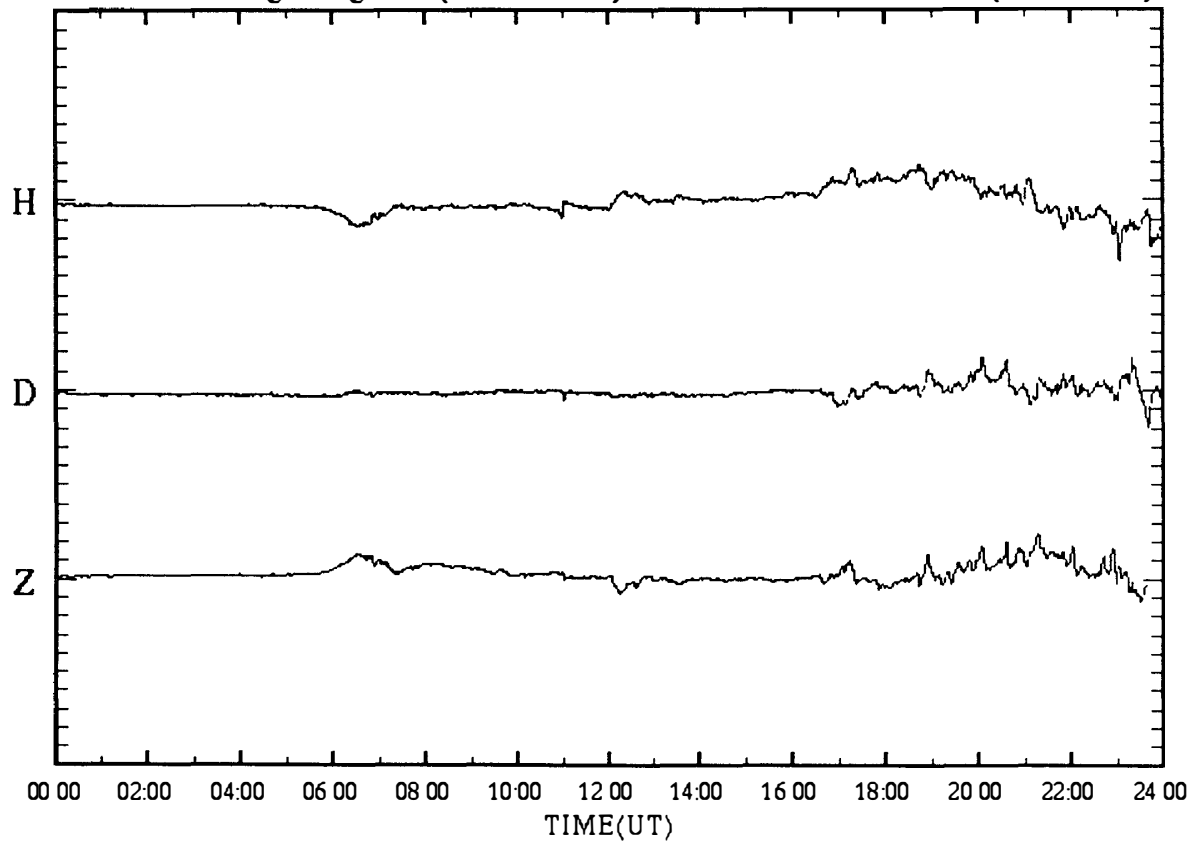

SYOWA magnetogram (100 nT/div)

09 Jun.1997 (DAY:160)

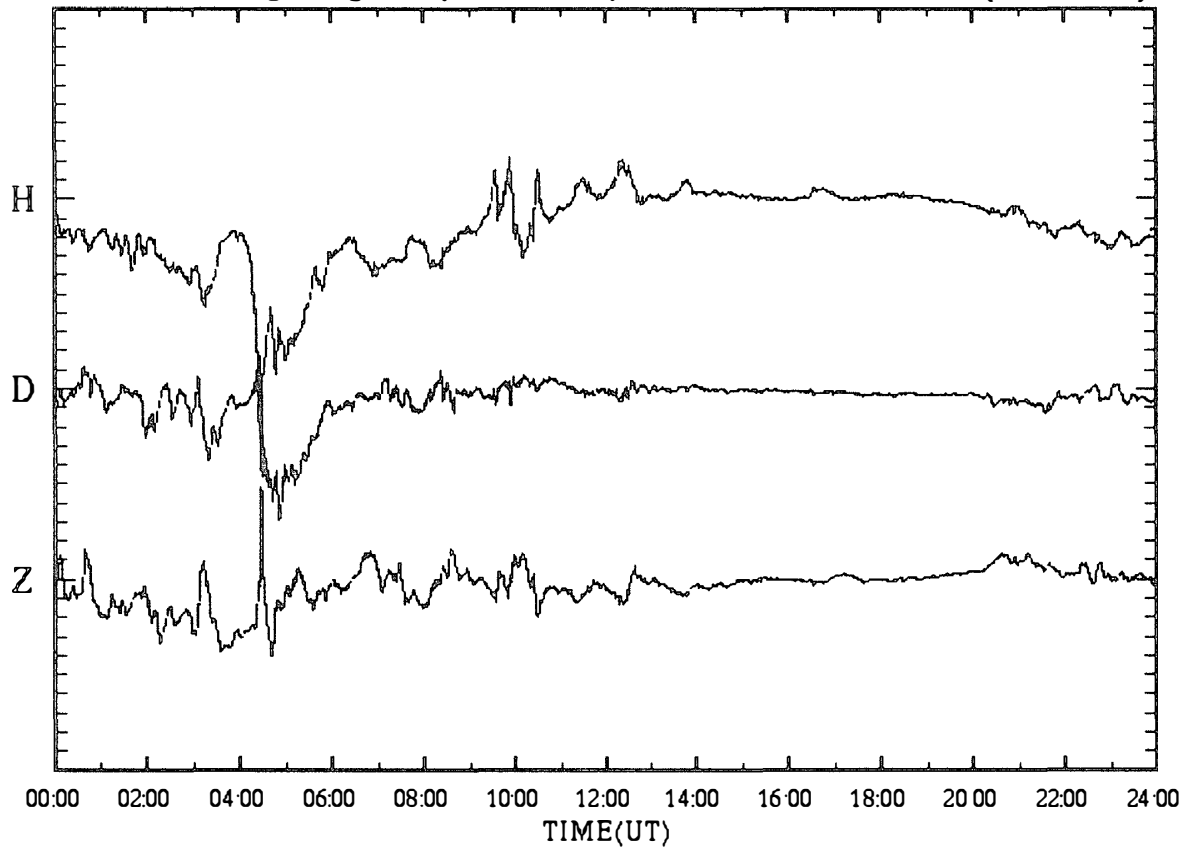

SYOWA magnetogram (100 nT/div)

10 Jun.1997 (DAY:161)

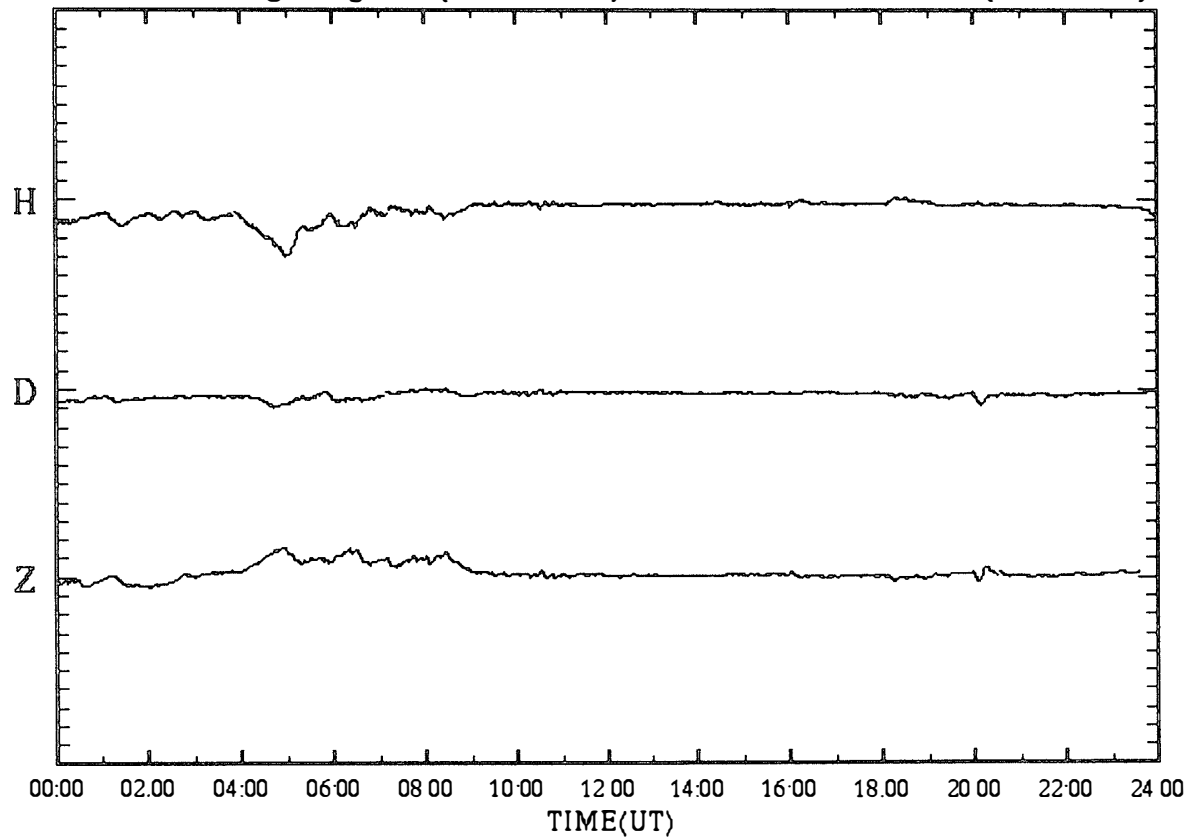

SYOWA magnetogram (100 nT/div)

11 Jun.1997 (DAY:162)

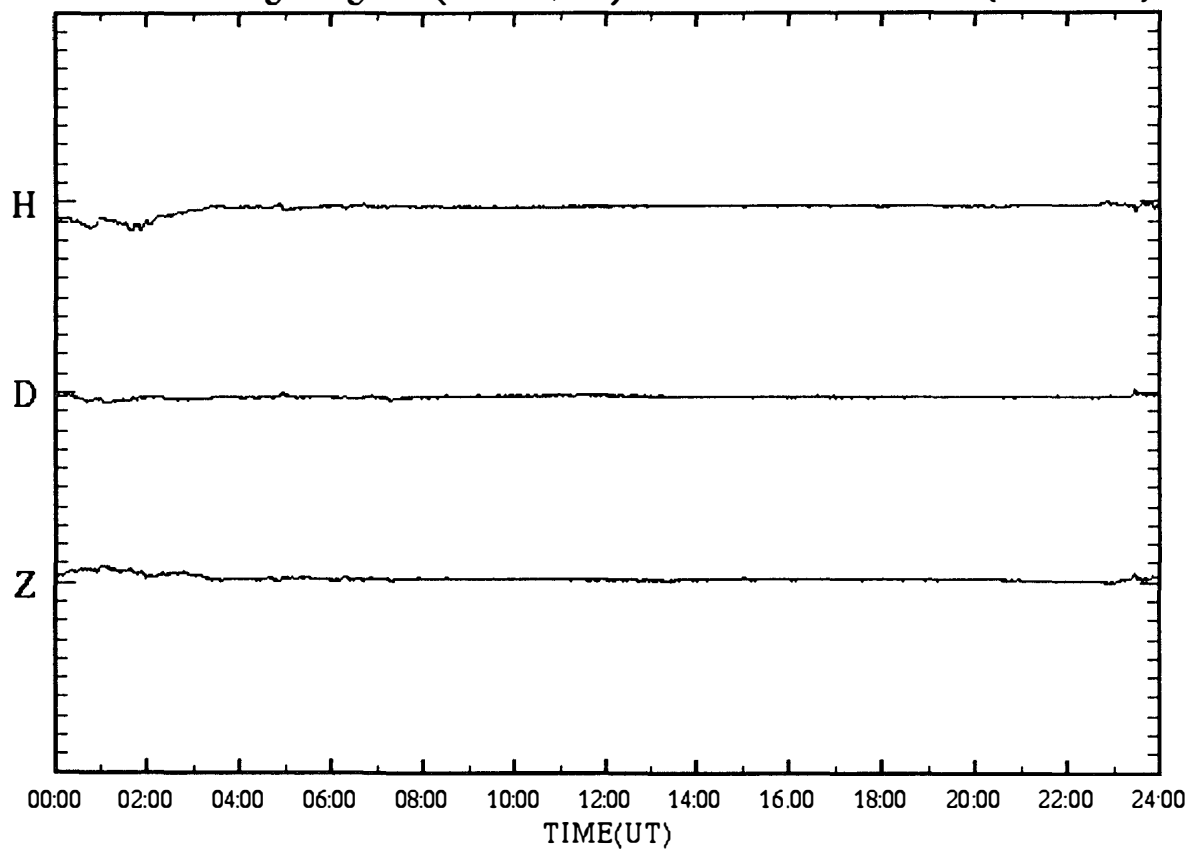

SYOWA magnetogram (100 nT/div)

12 Jun.1997 (DAY:163)

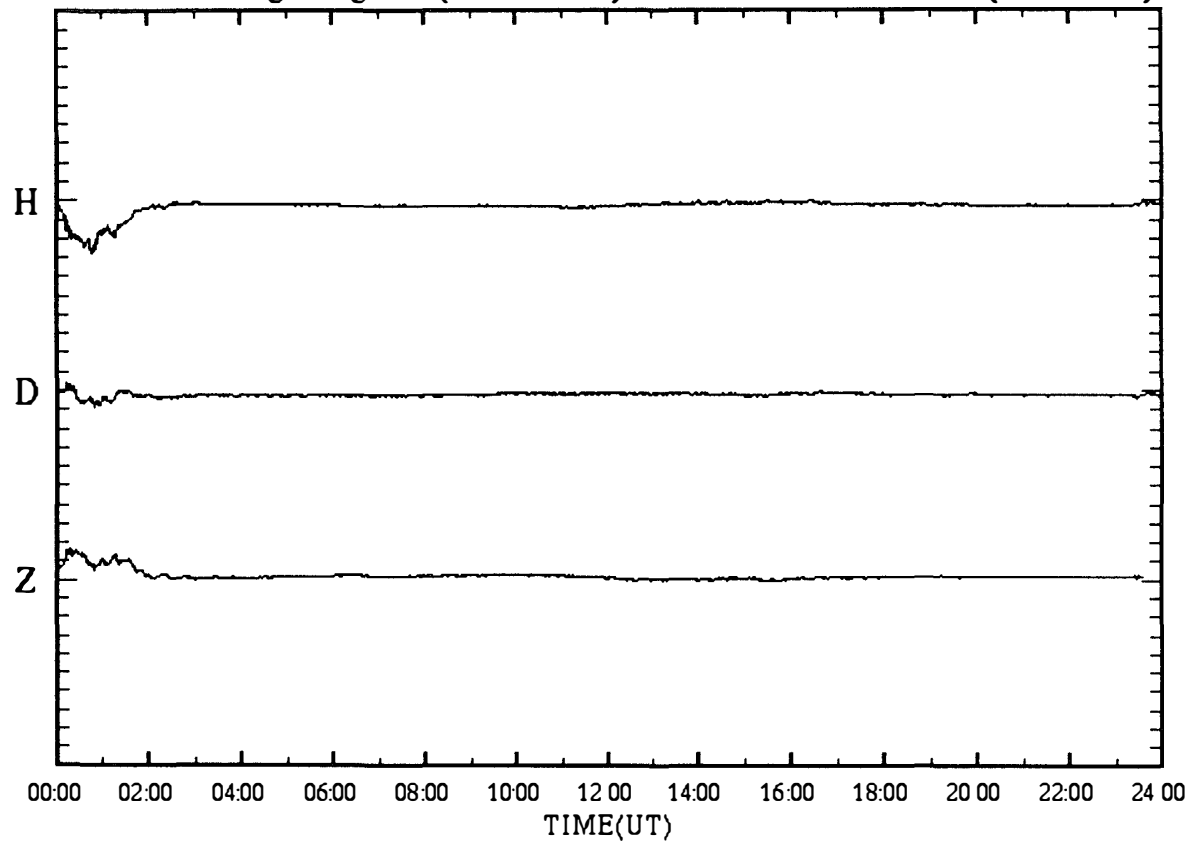

SYOWA magnetogram (100 nT/div)

13 Jun.1997 (DAY:164)

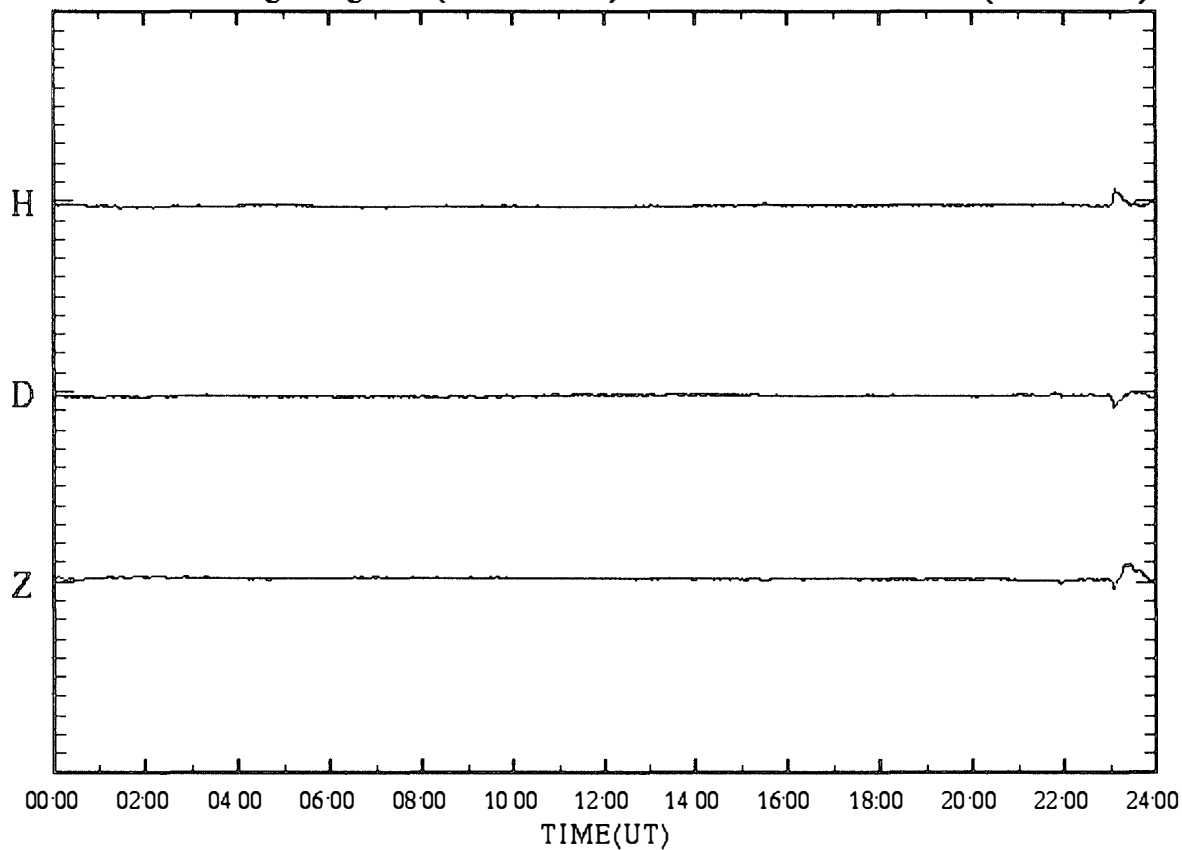

SYOWA magnetogram (100 nT/div)

14 Jun.1997 (DAY:165)

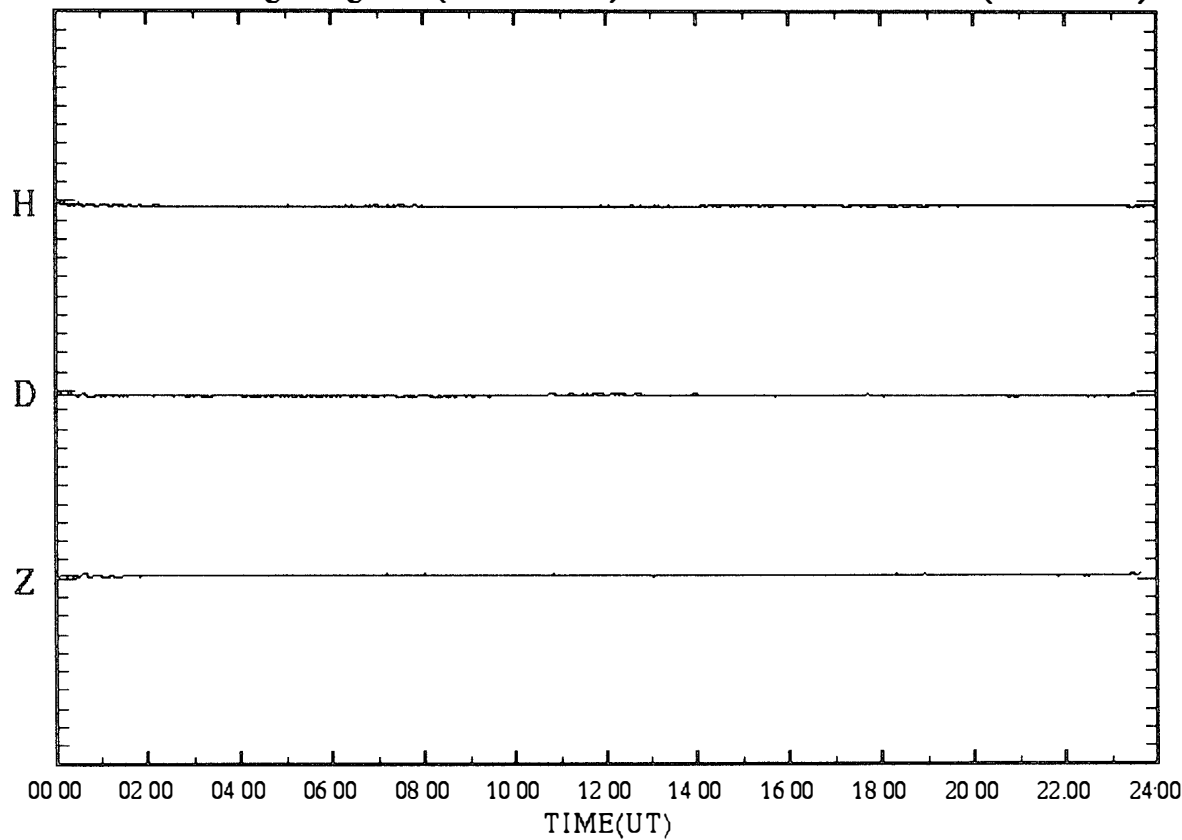



SYOWA magnetogram (100 nT/div)

15 Jun.1997 (DAY:166)

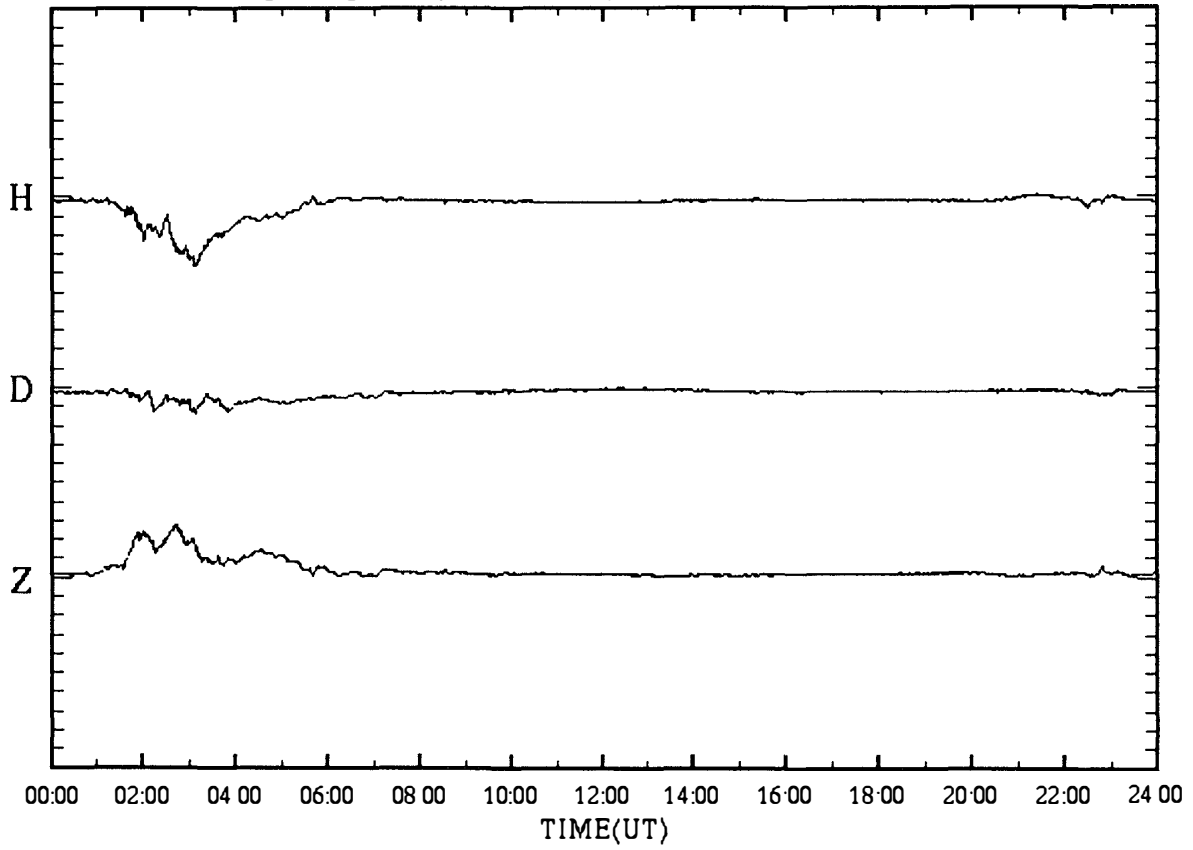

SYOWA magnetogram (100 nT/div)

16 Jun.1997 (DAY:167)

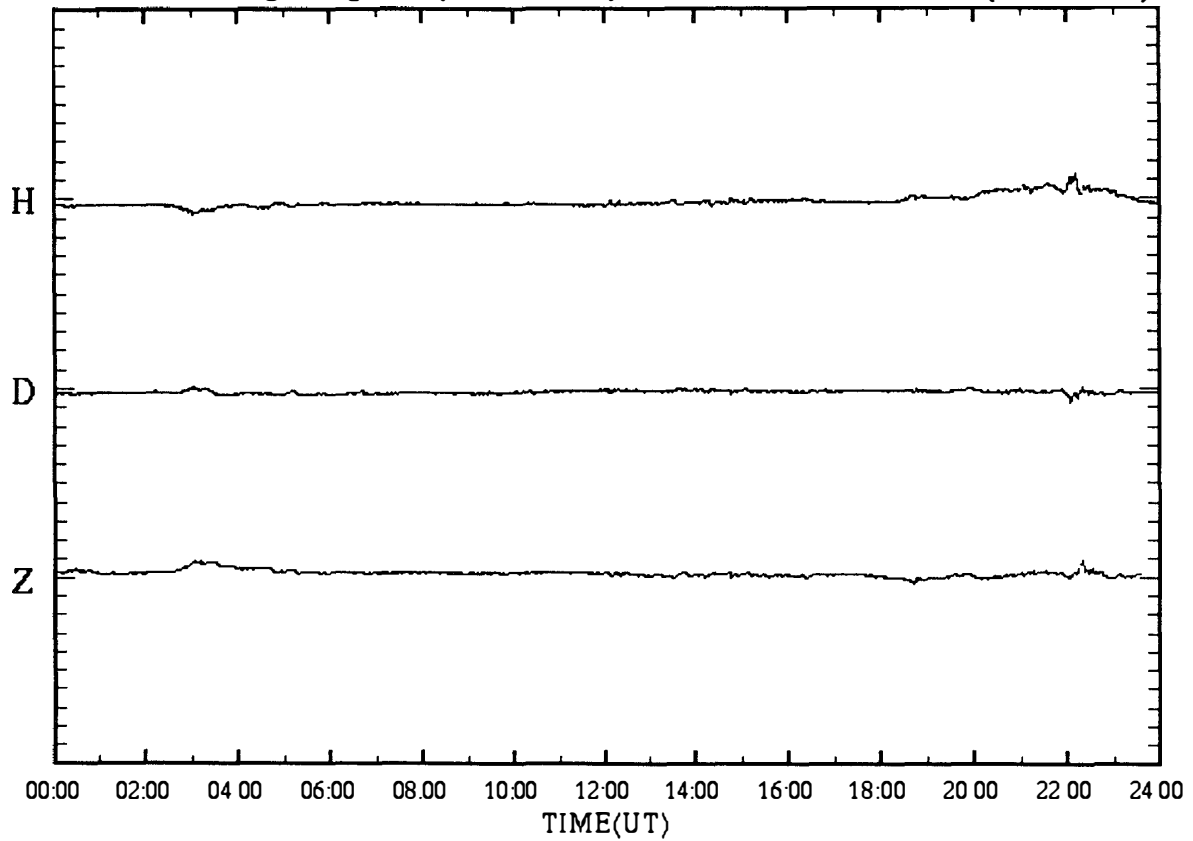

SYOWA magnetogram (100 nT/div)

17 Jun.1997 (DAY:168)

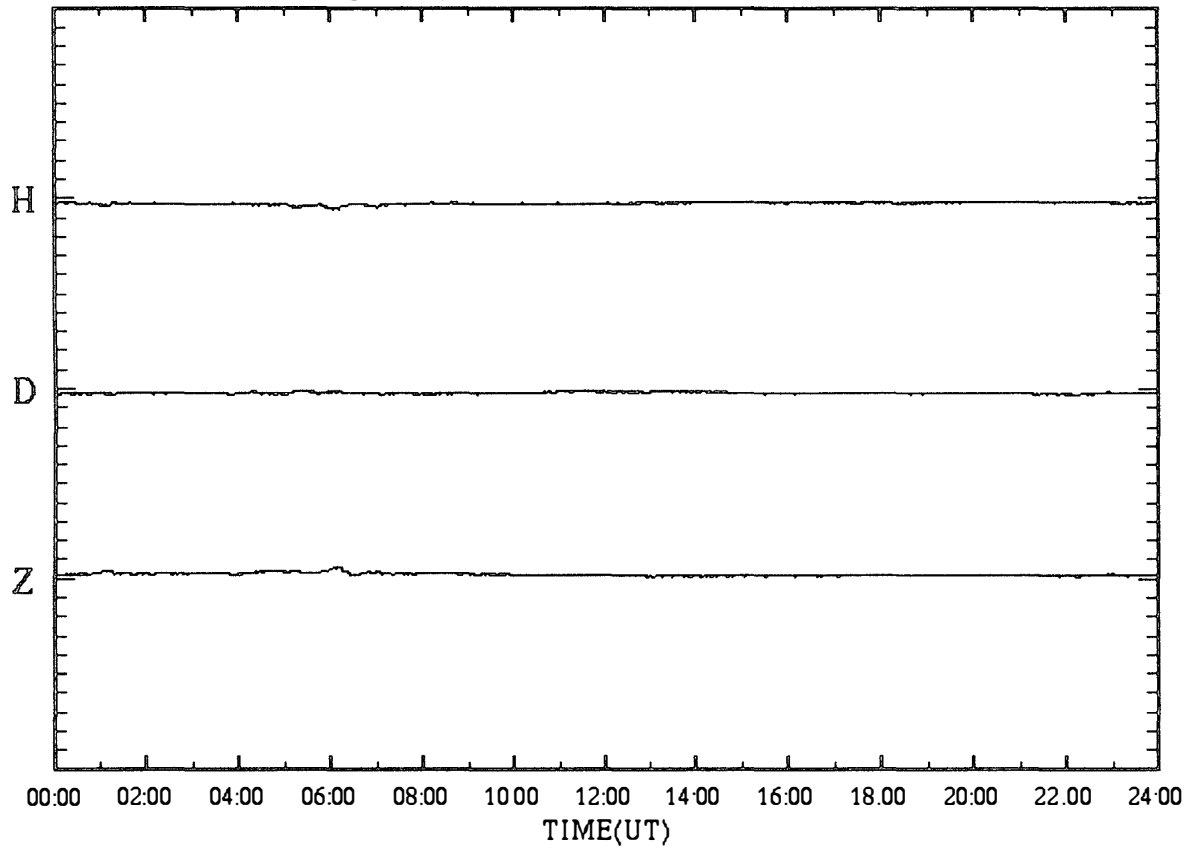

SYOWA magnetogram (100 nT/div)

18 Jun.1997 (DAY:169)

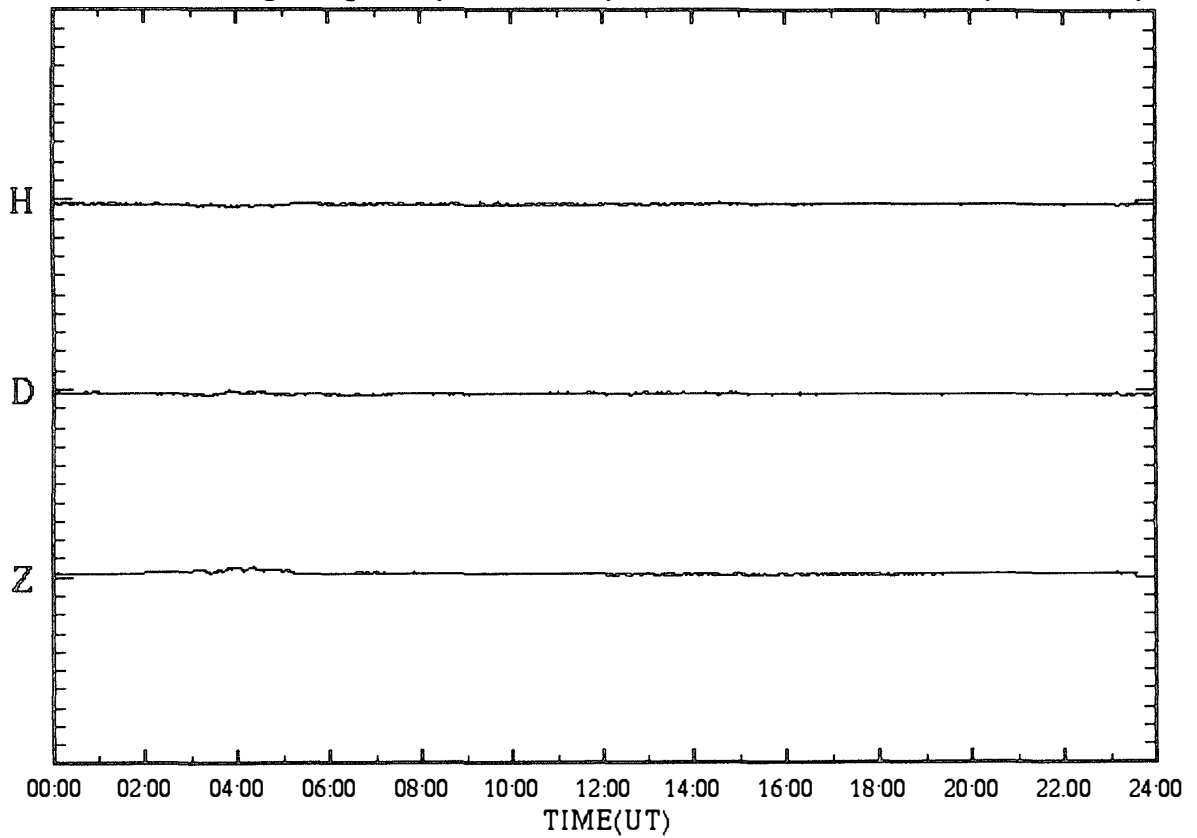

SYOWA magnetogram (100 nT/div)

19 Jun.1997 (DAY:170)

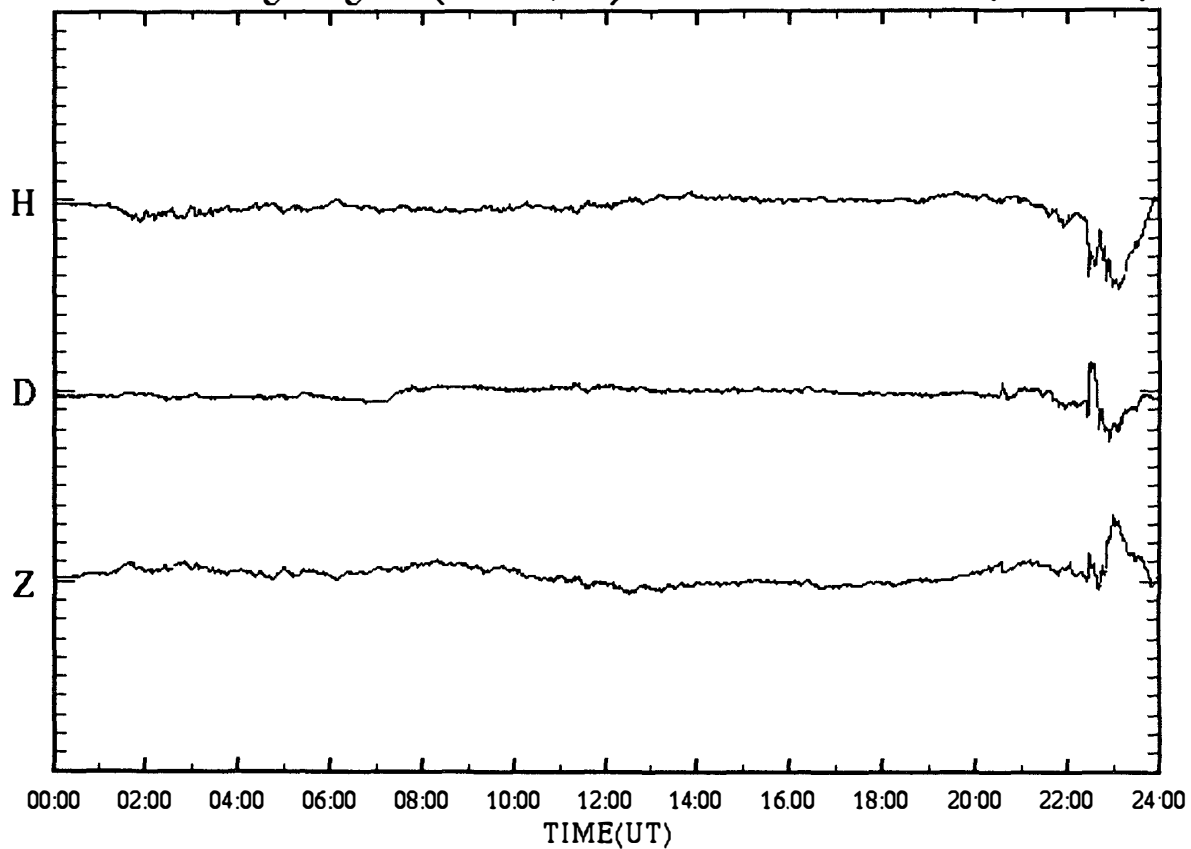

SYOWA magnetogram (100 nT/div)

20 Jun.1997 (DAY:171)

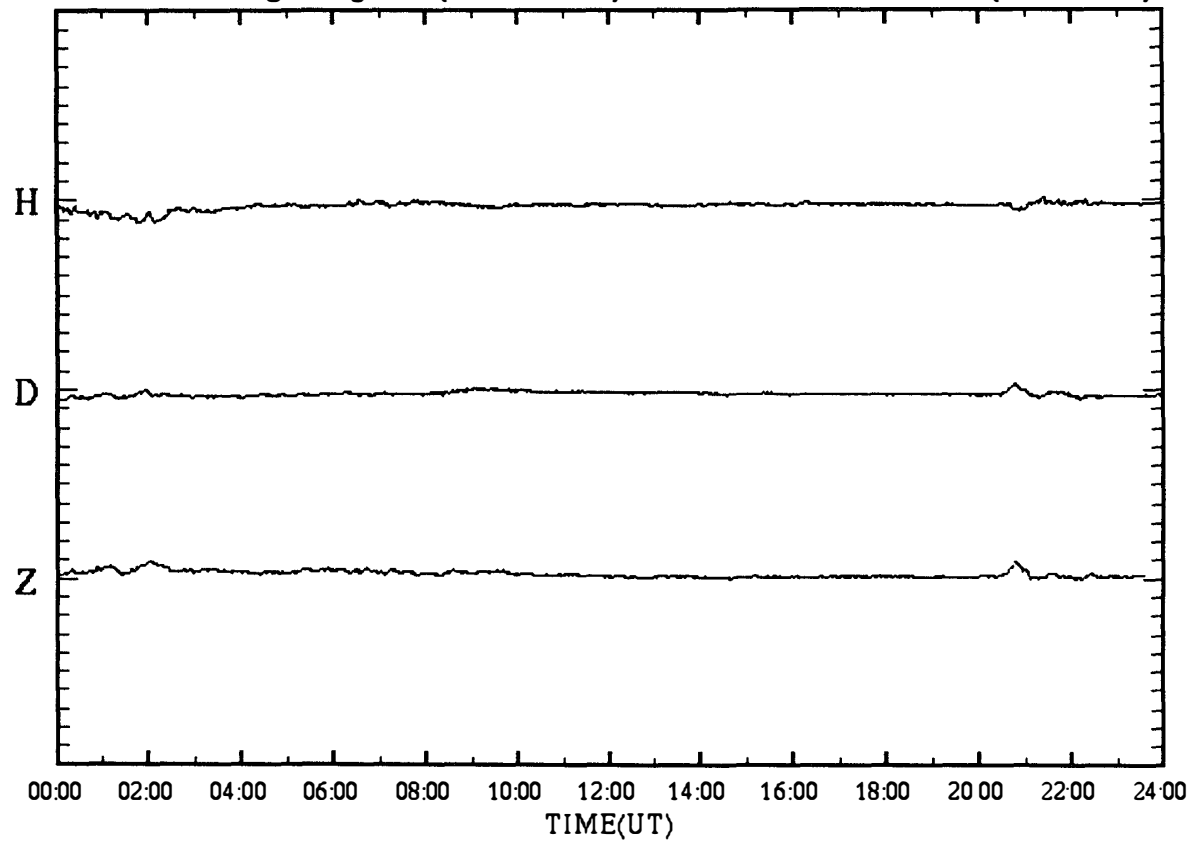

SYOWA magnetogram (100 nT/div)

21 Jun.1997 (DAY:172)

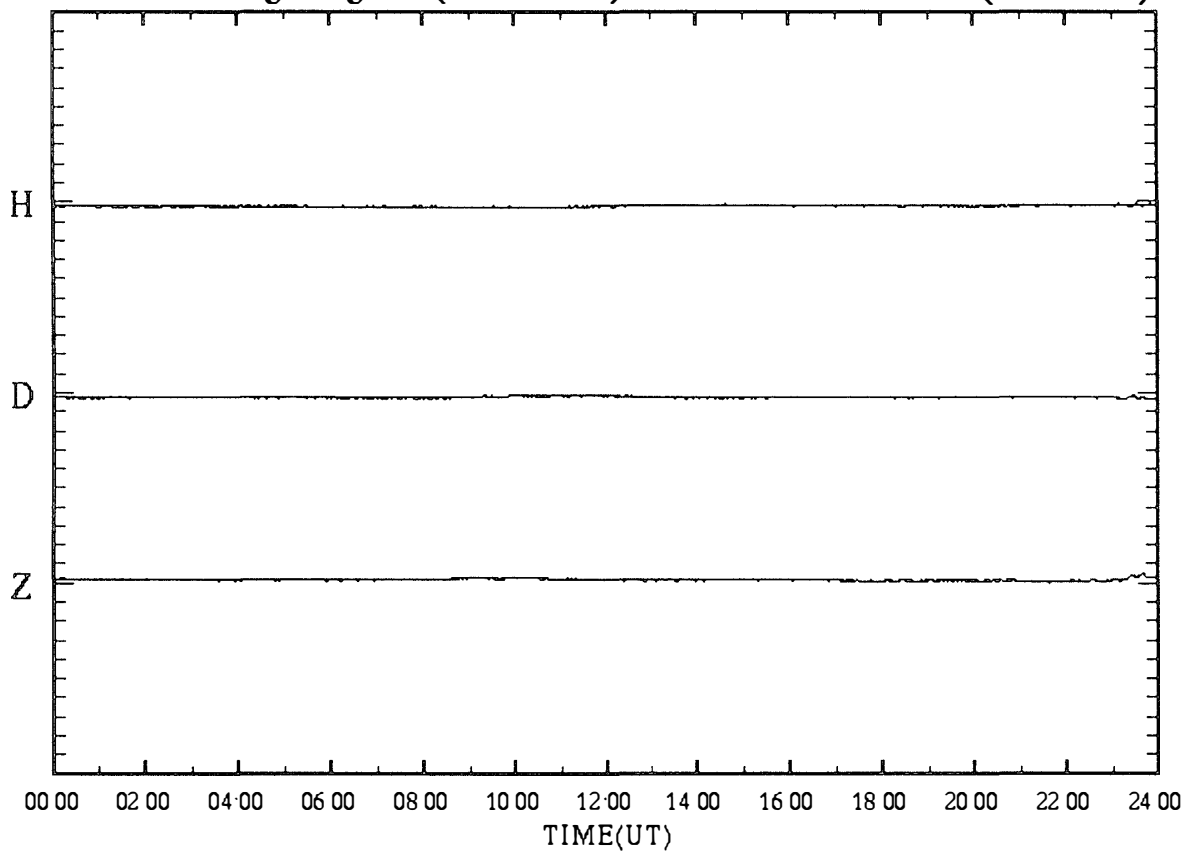

SYOWA magnetogram (100 nT/div)

22 Jun.1997 (DAY:173)

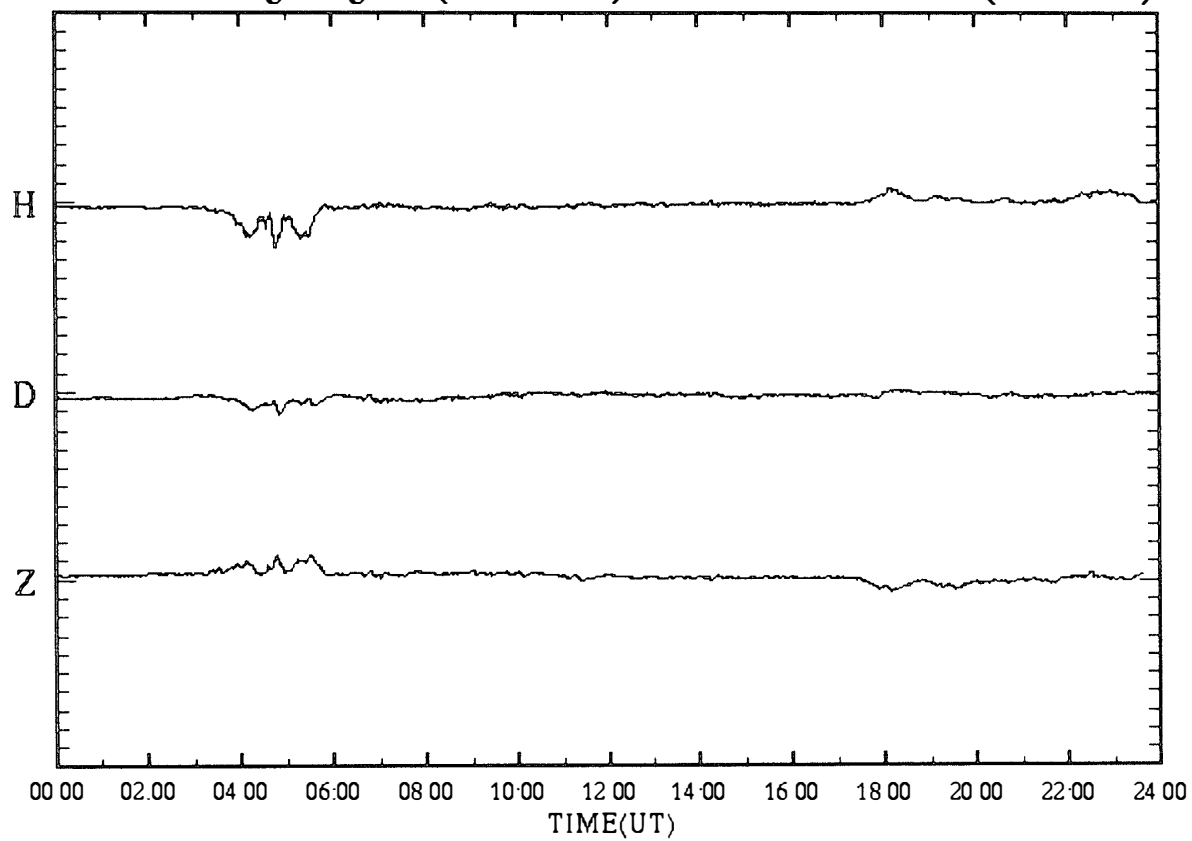

SYOWA magnetogram (100 nT/div)

23 Jun.1997 (DAY:174)

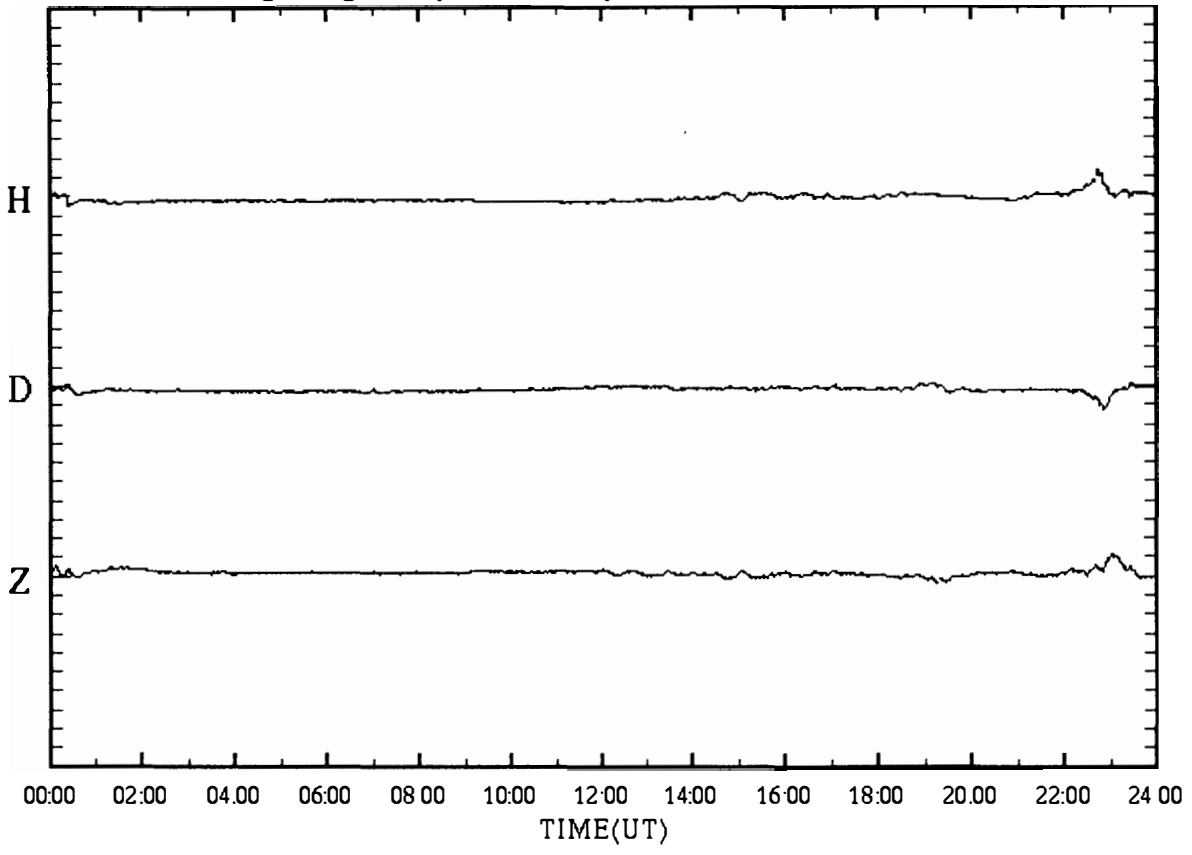

SYOWA magnetogram (100 nT/div)

24 Jun.1997 (DAY:175)

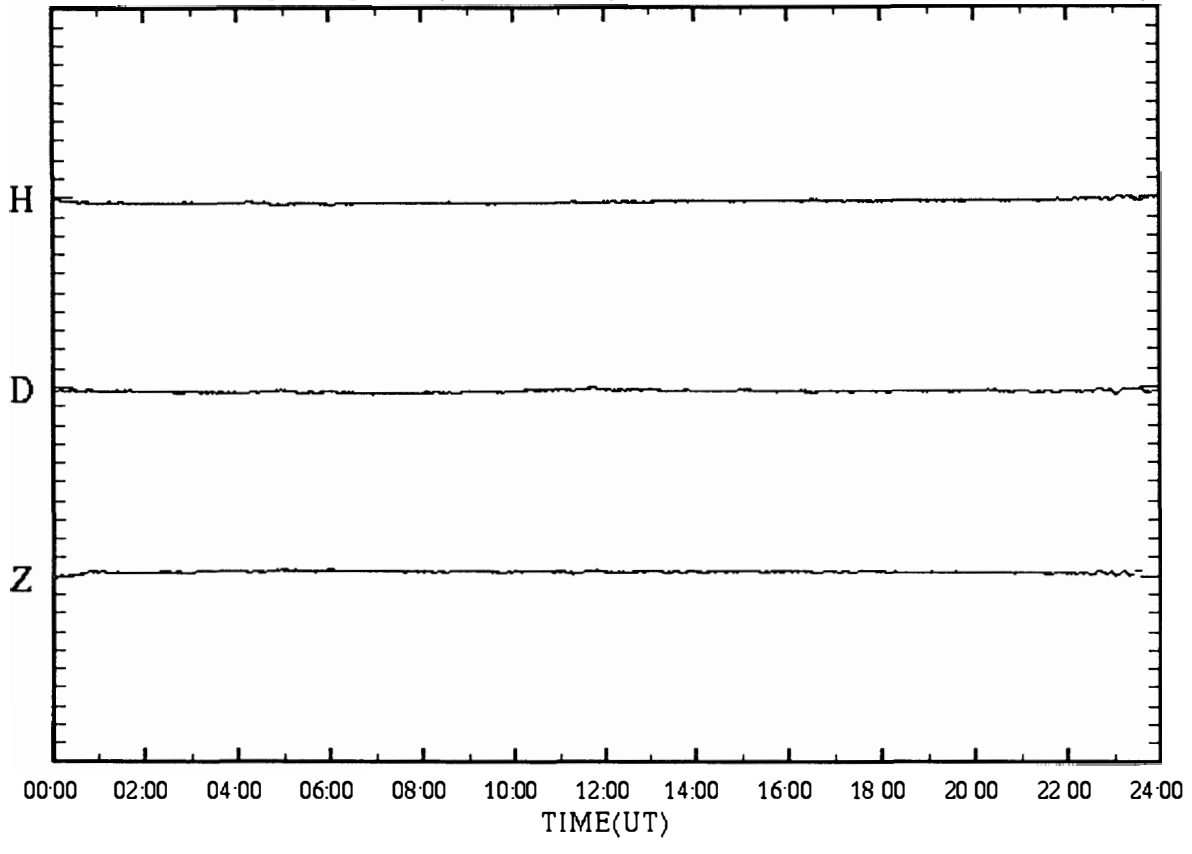

SYOWA magnetogram (100 nT/div)

25 Jun.1997 (DAY:176)

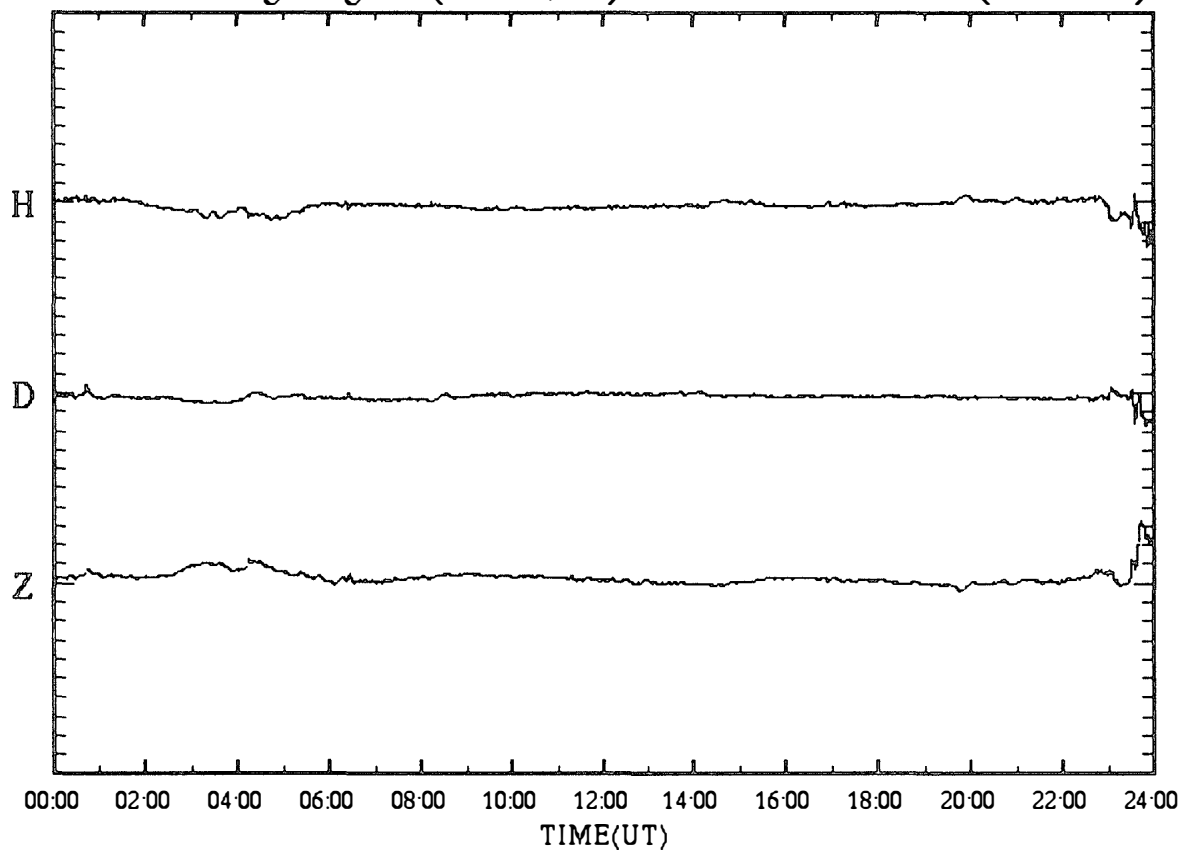

SYOWA magnetogram (100 nT/div)

26 Jun.1997 (DAY:177)

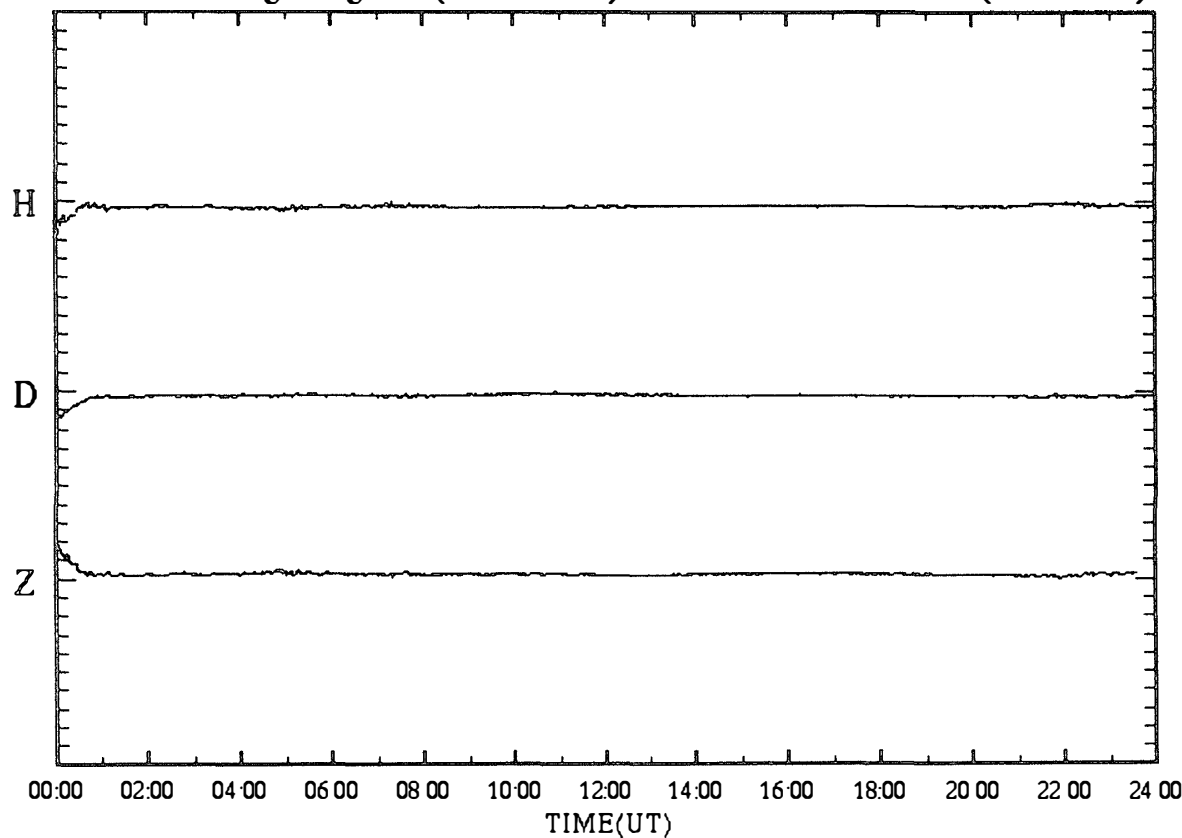

SYOWA magnetogram (100 nT/div)

27 Jun.1997 (DAY:178)

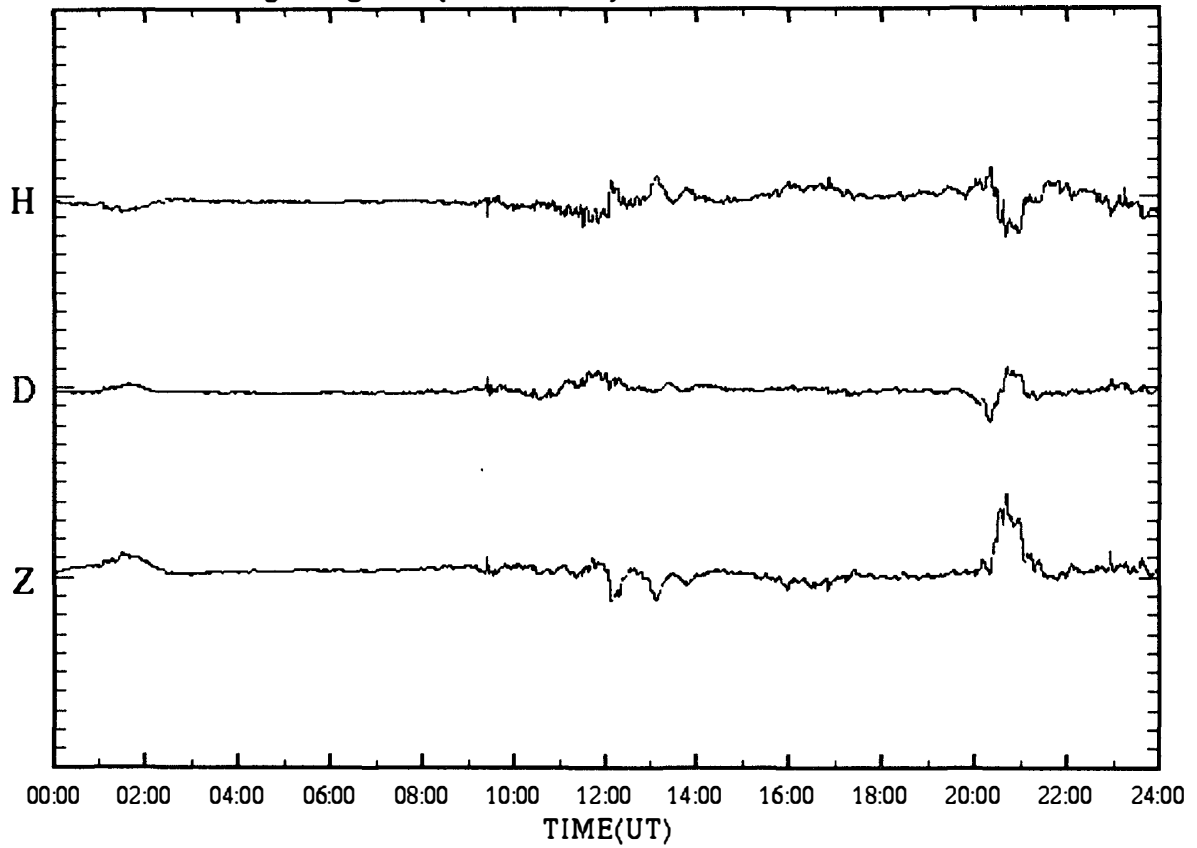

SYOWA magnetogram (100 nT/div)

28 Jun.1997 (DAY:179)

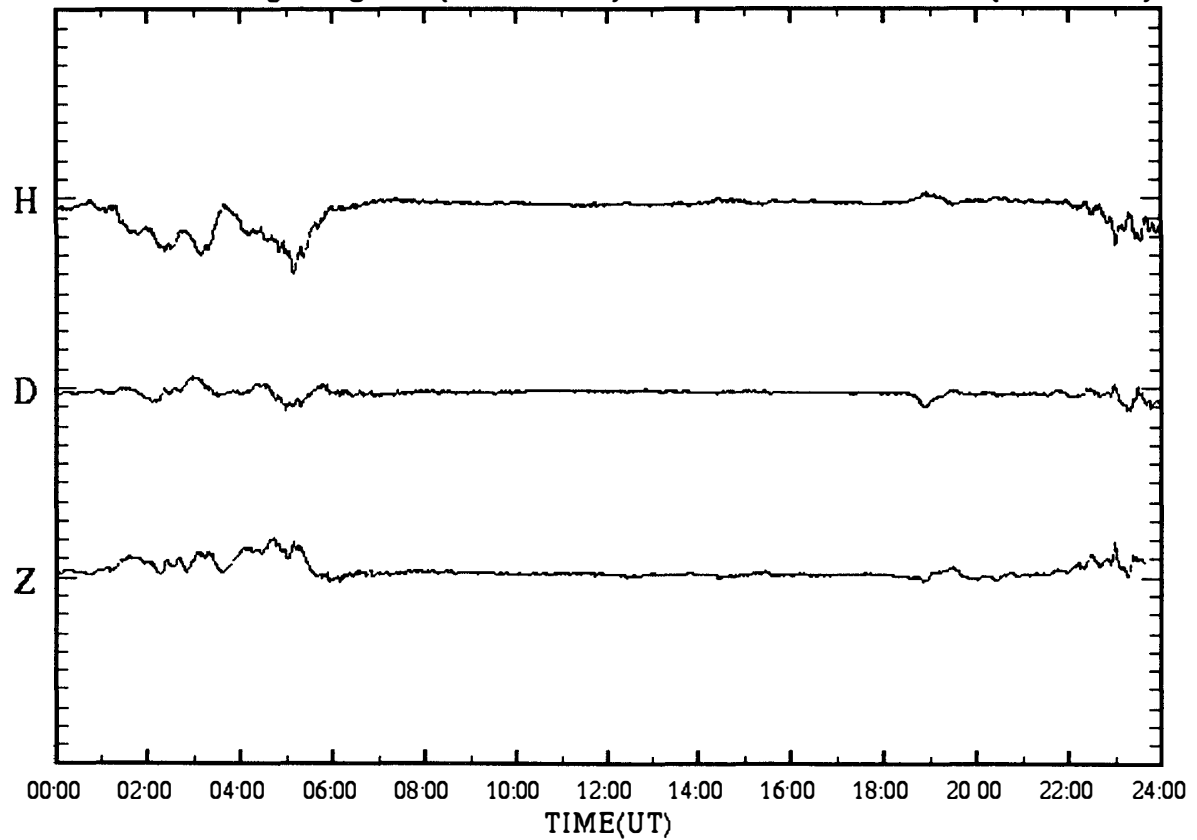

SYOWA magnetogram (100 nT/div)

29 Jun.1997 (DAY:180)

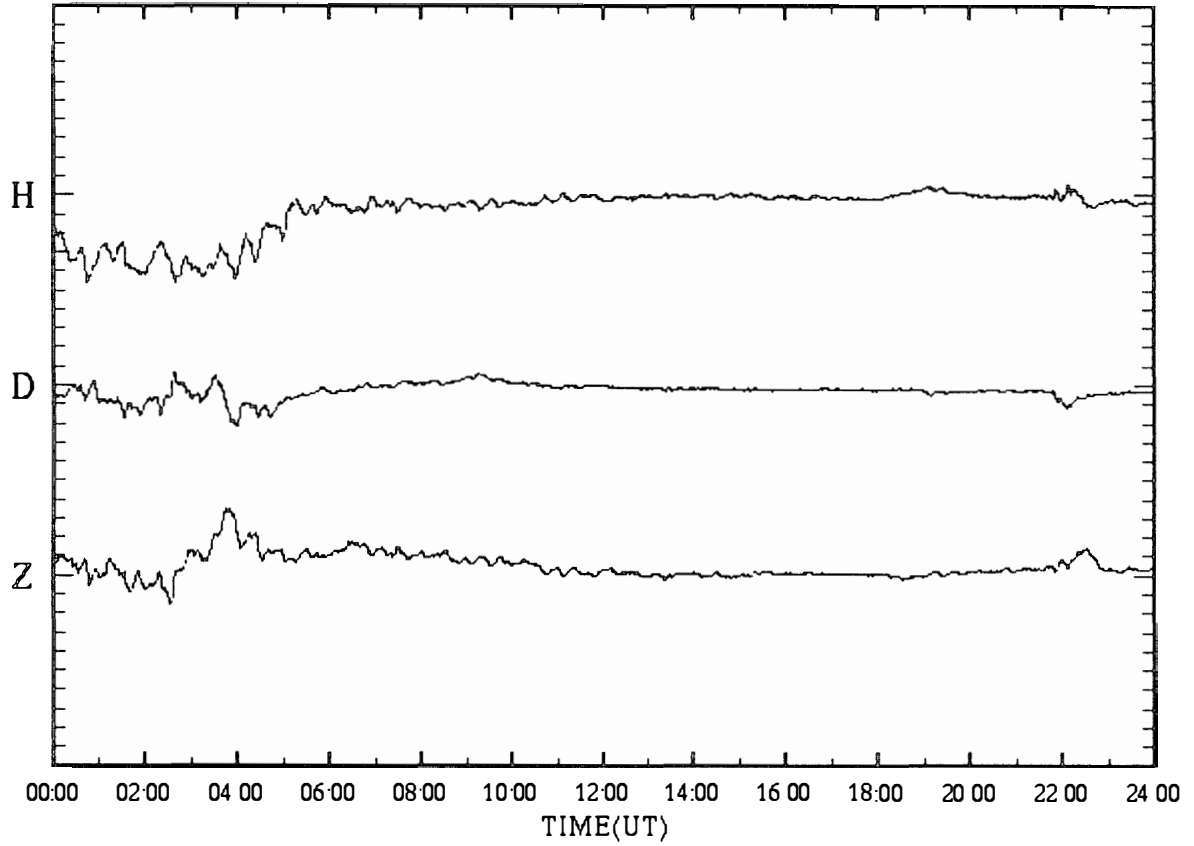

SYOWA magnetogram (100 nT/div)

30 Jun.1997 (DAY:181)

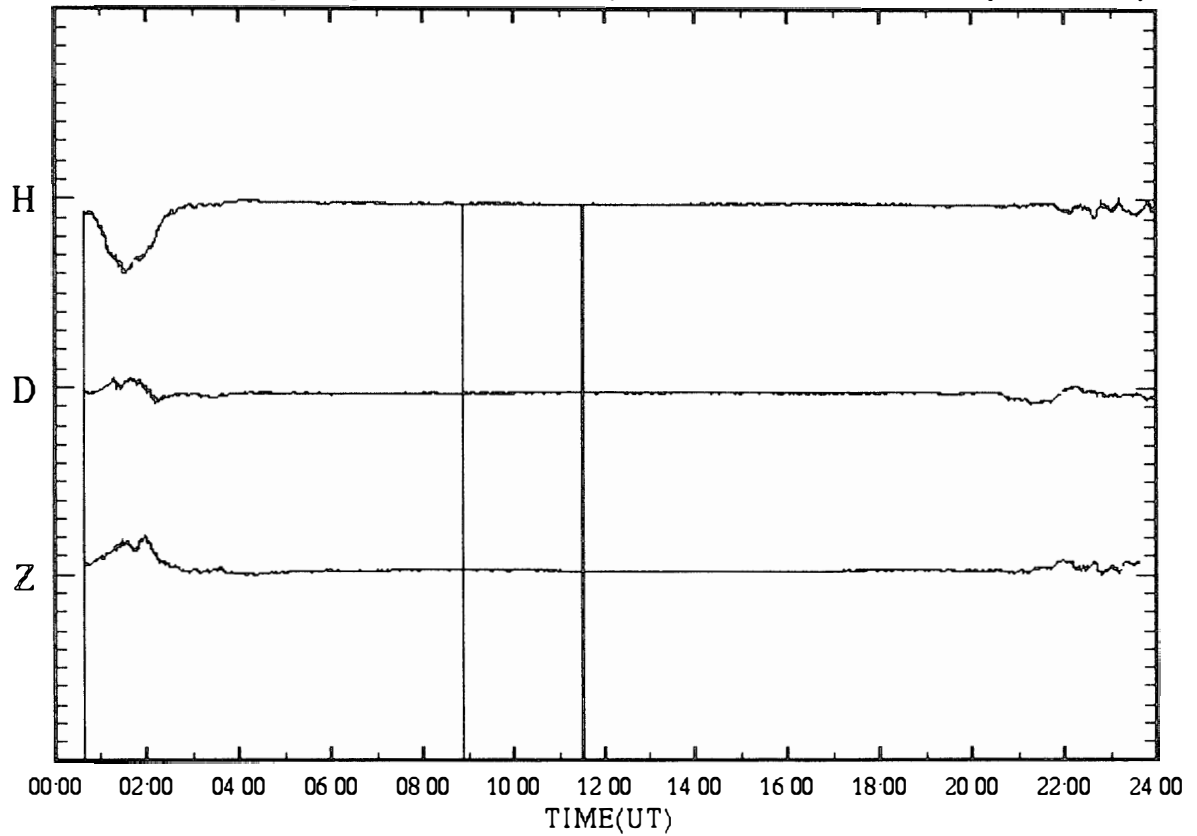



SYOWA magnetogram (100 nT/div)

01 Jul.1997 (DAY:182)

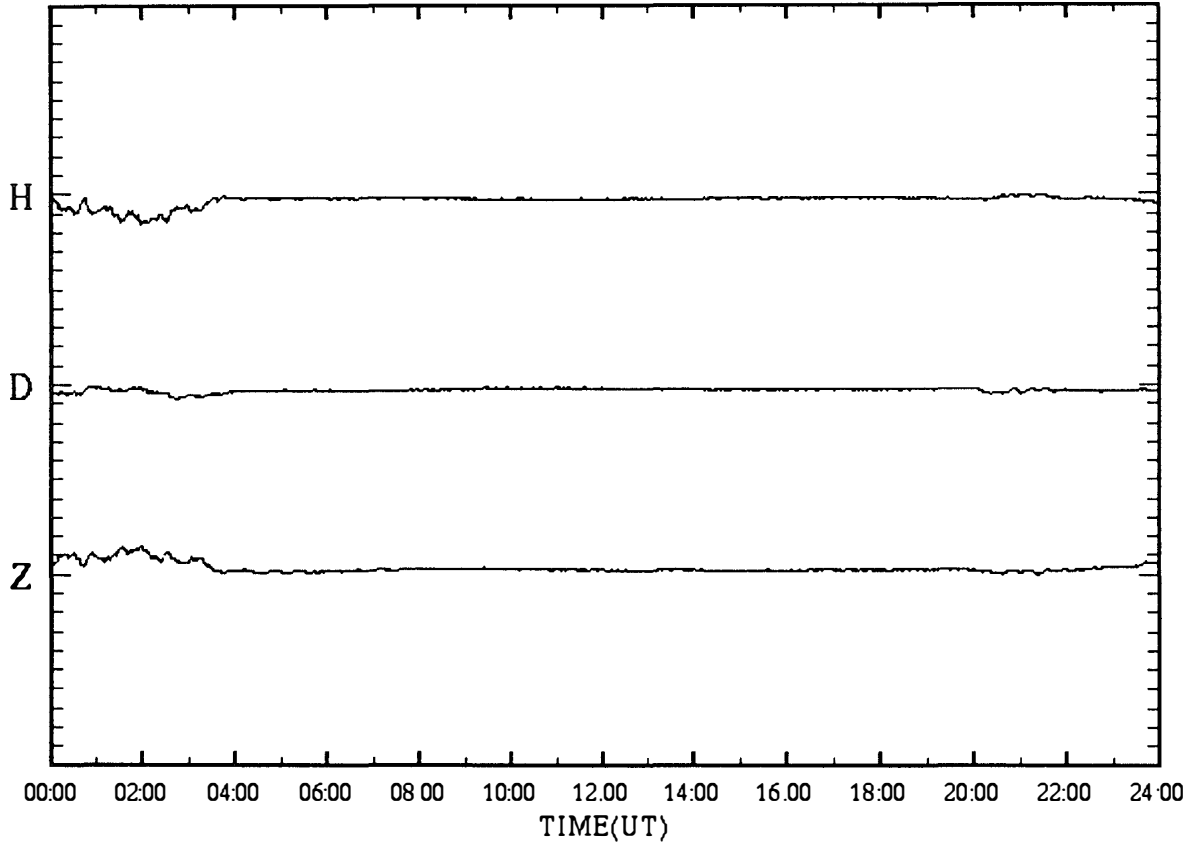

SYOWA magnetogram (100 nT/div)

02 Jul.1997 (DAY:183)

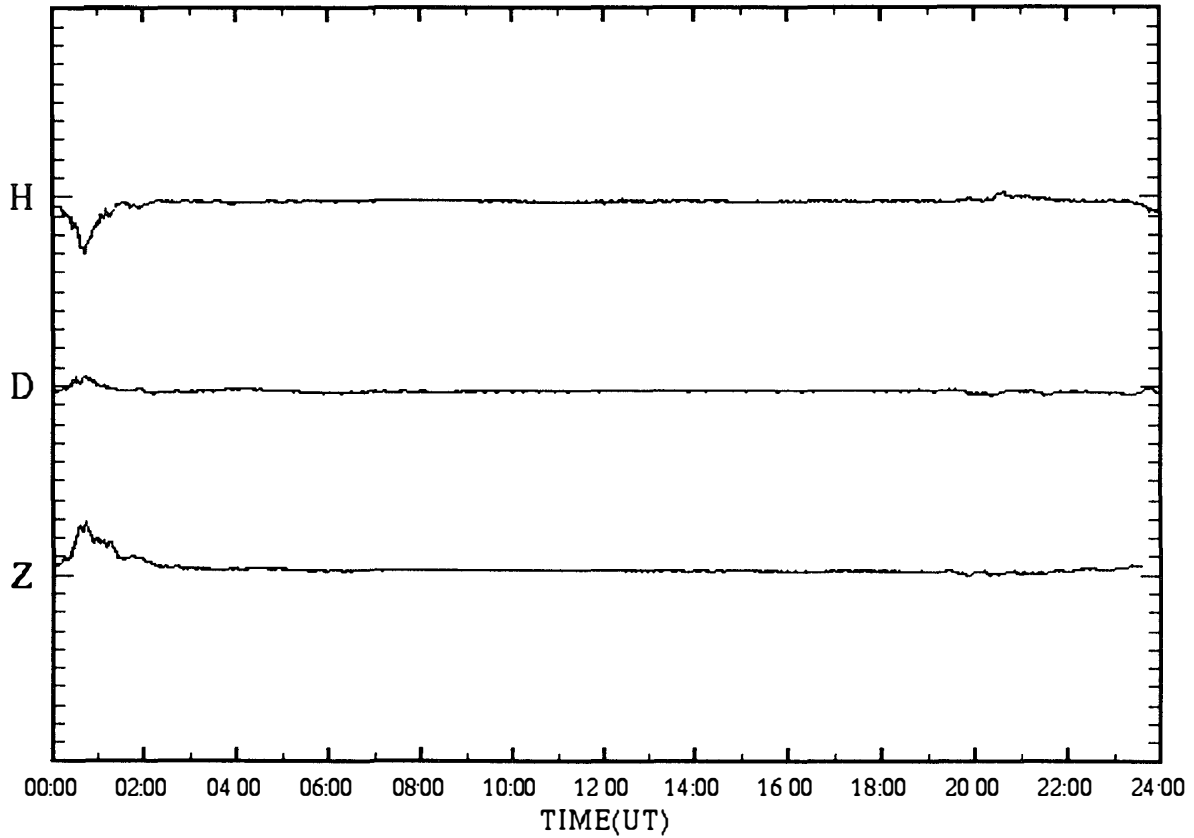

SYOWA magnetogram (100 nT/div)

03 Jul.1997 (DAY:184)

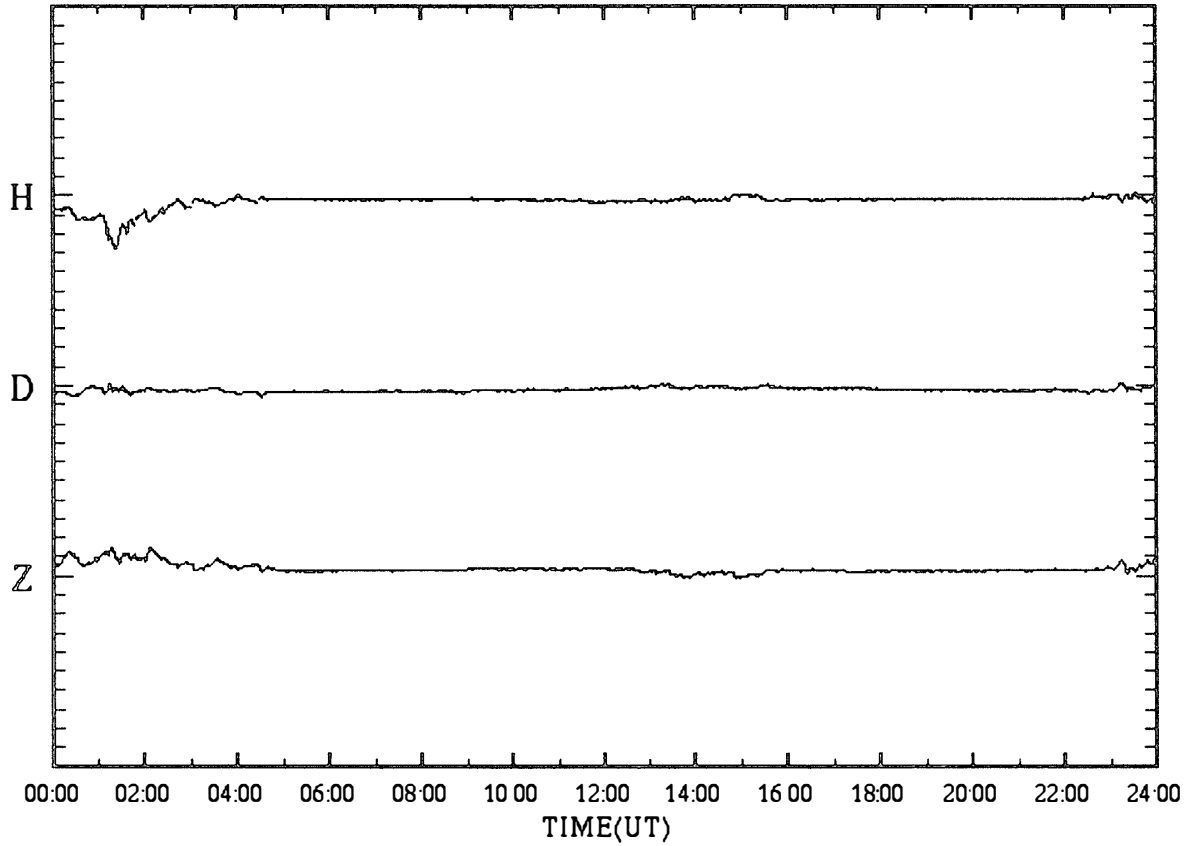

SYOWA magnetogram (100 nT/div)

04 Jul.1997 (DAY:185)

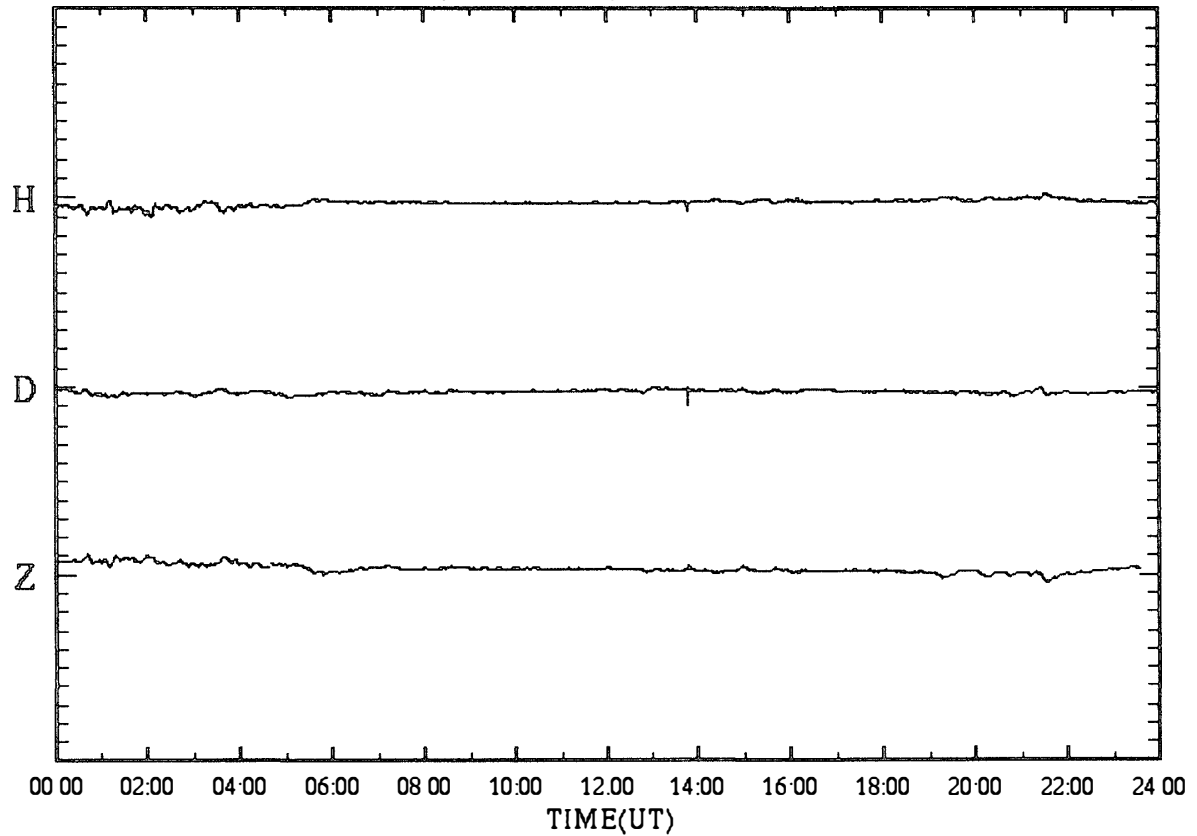

SYOWA magnetogram (100 nT/div)

05 Jul.1997 (DAY:186)

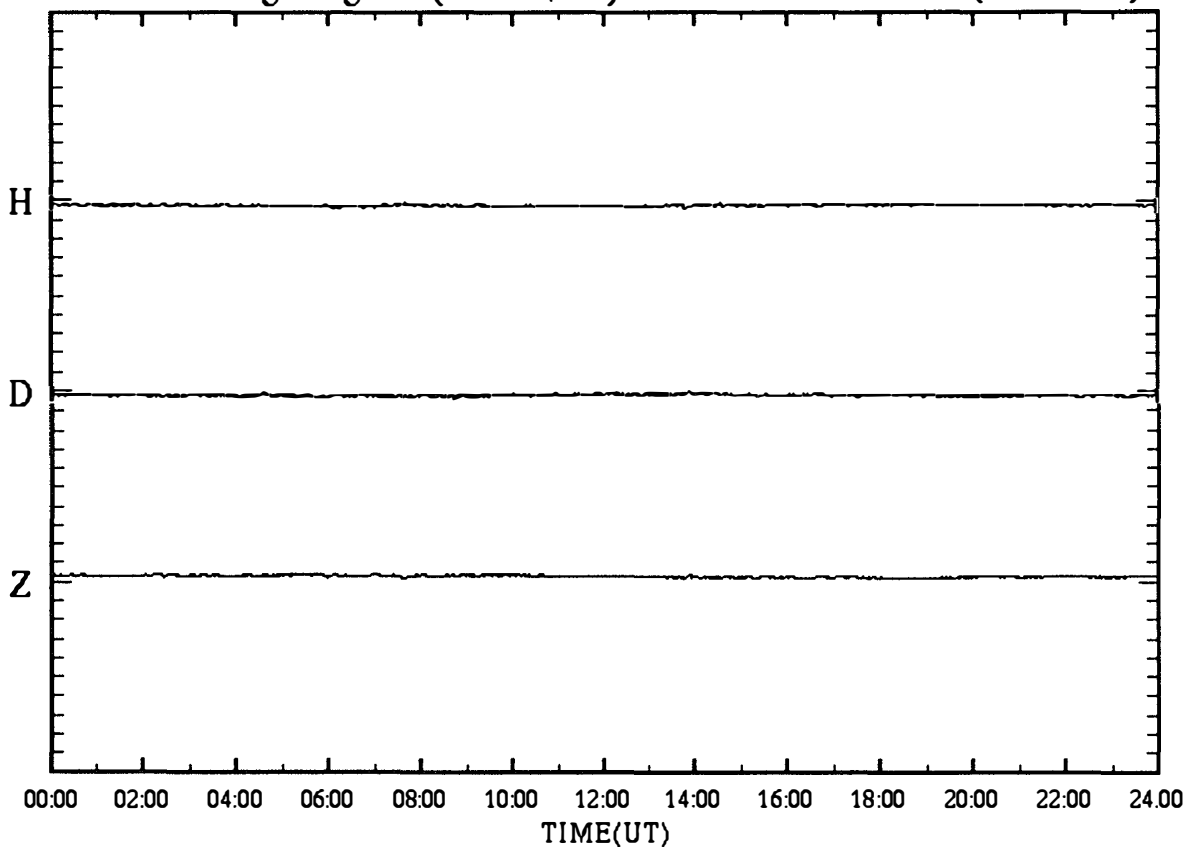

SYOWA magnetogram (100 nT/div)

06 Jul.1997 (DAY:187)

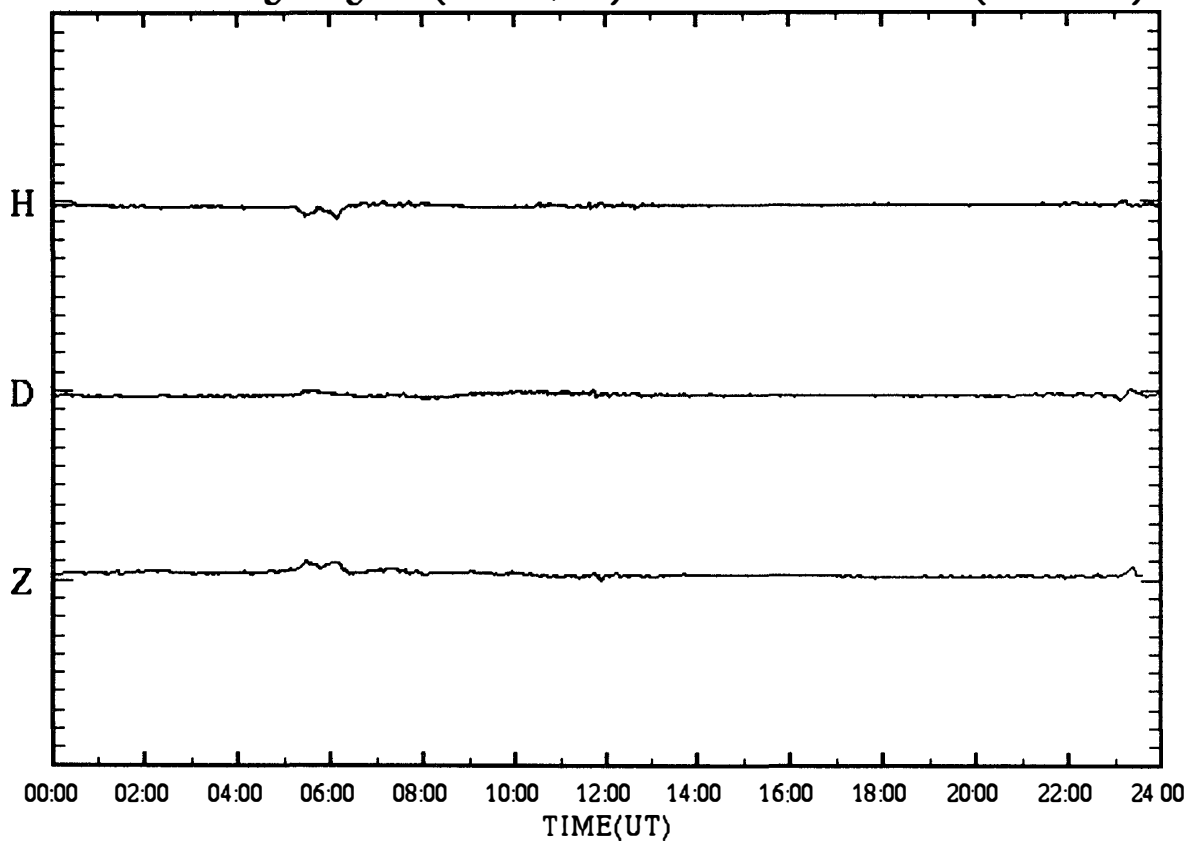

SYOWA magnetogram (100 nT/div)

07 Jul.1997 (DAY:188)

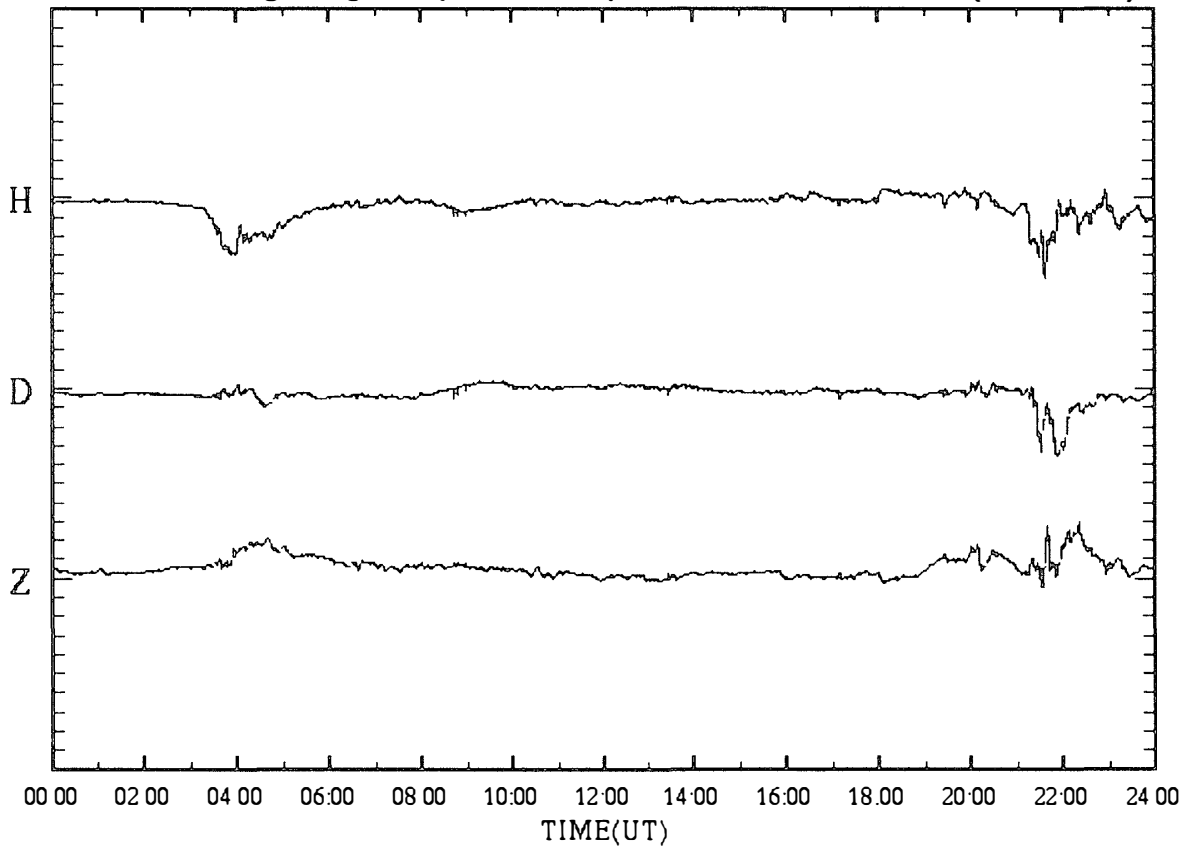

SYOWA magnetogram (100 nT/div)

08 Jul.1997 (DAY:189)

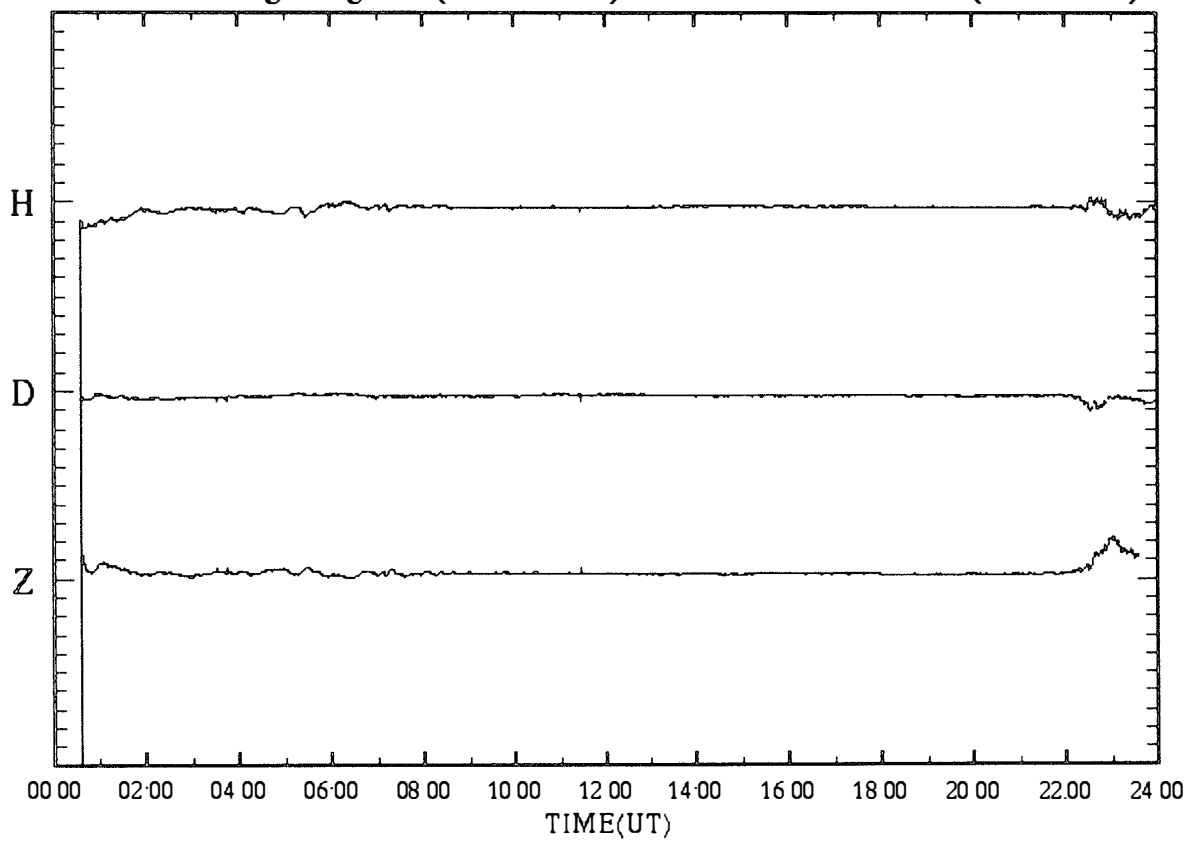

SYOWA magnetogram (100 nT/div)

09 Jul.1997 (DAY:190)

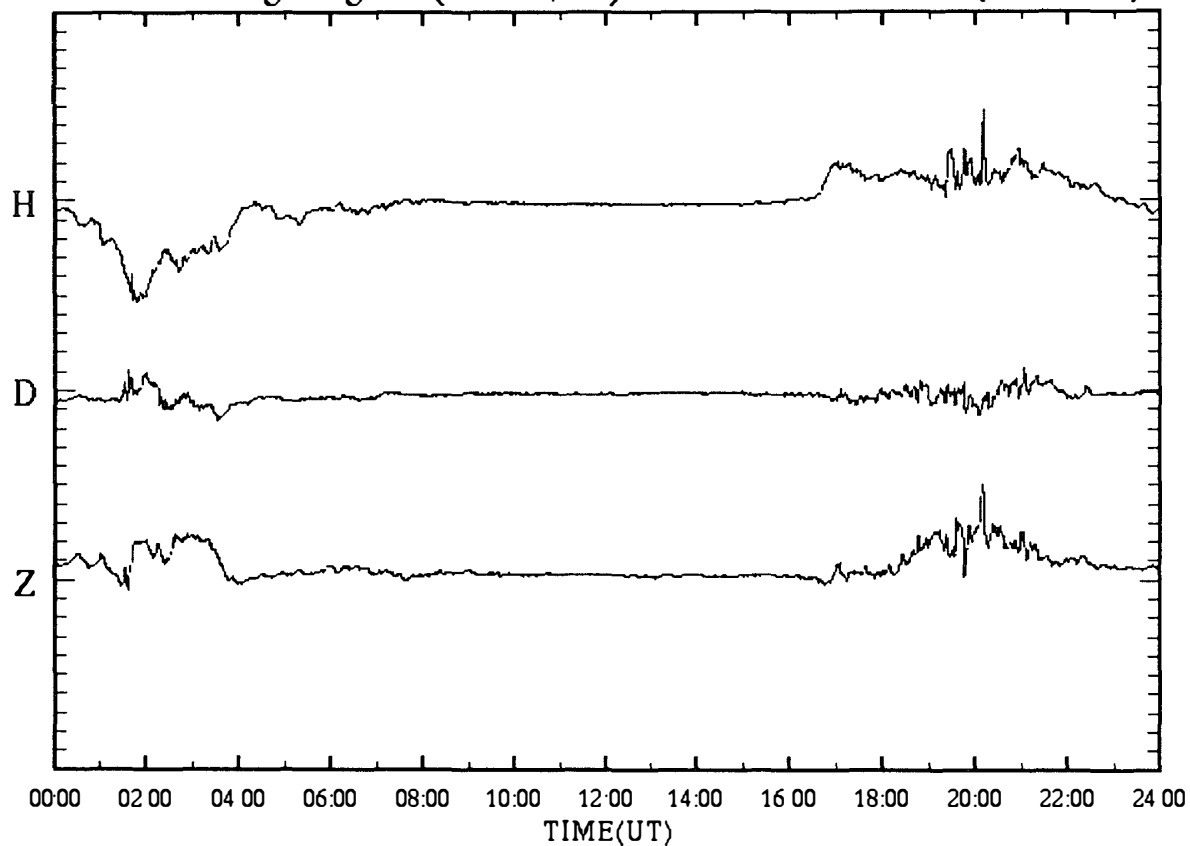

SYOWA magnetogram (100 nT/div)

10 Jul.1997 (DAY:191)

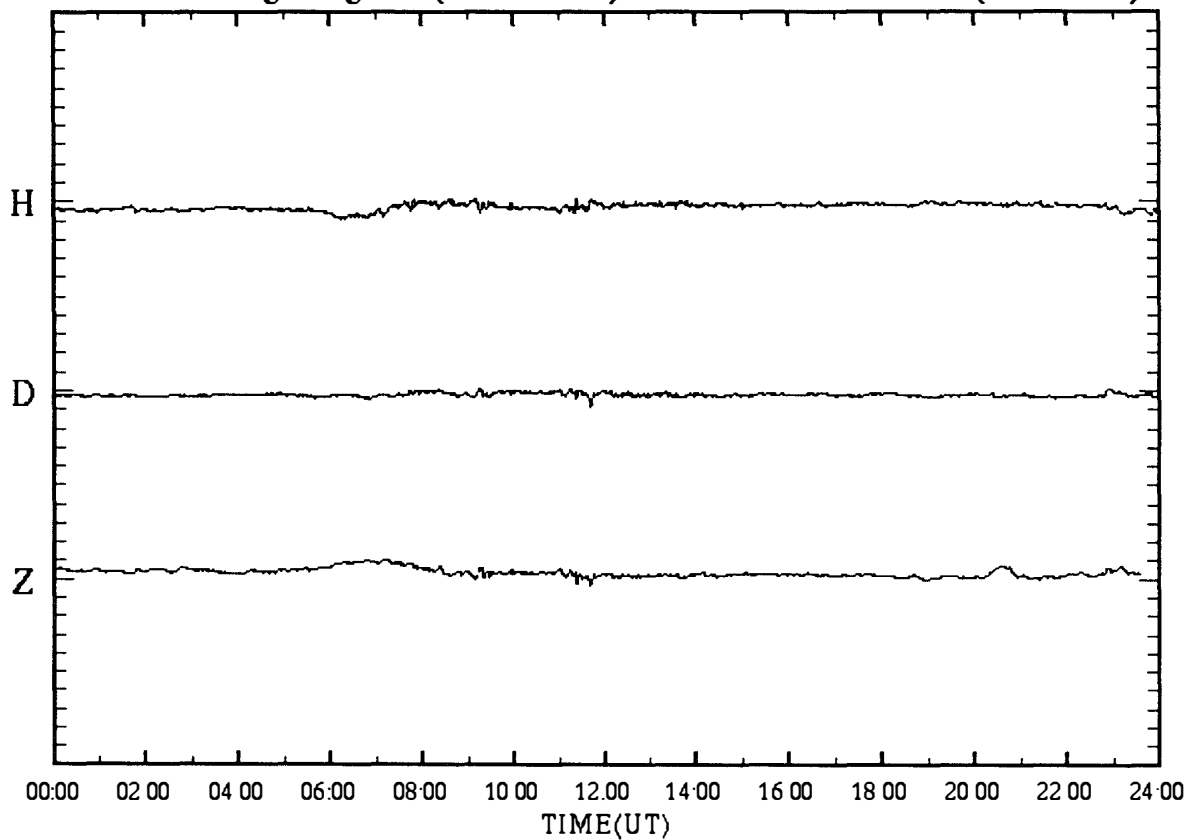

SYOWA magnetogram (100 nT/div)

11 Jul.1997 (DAY:192)

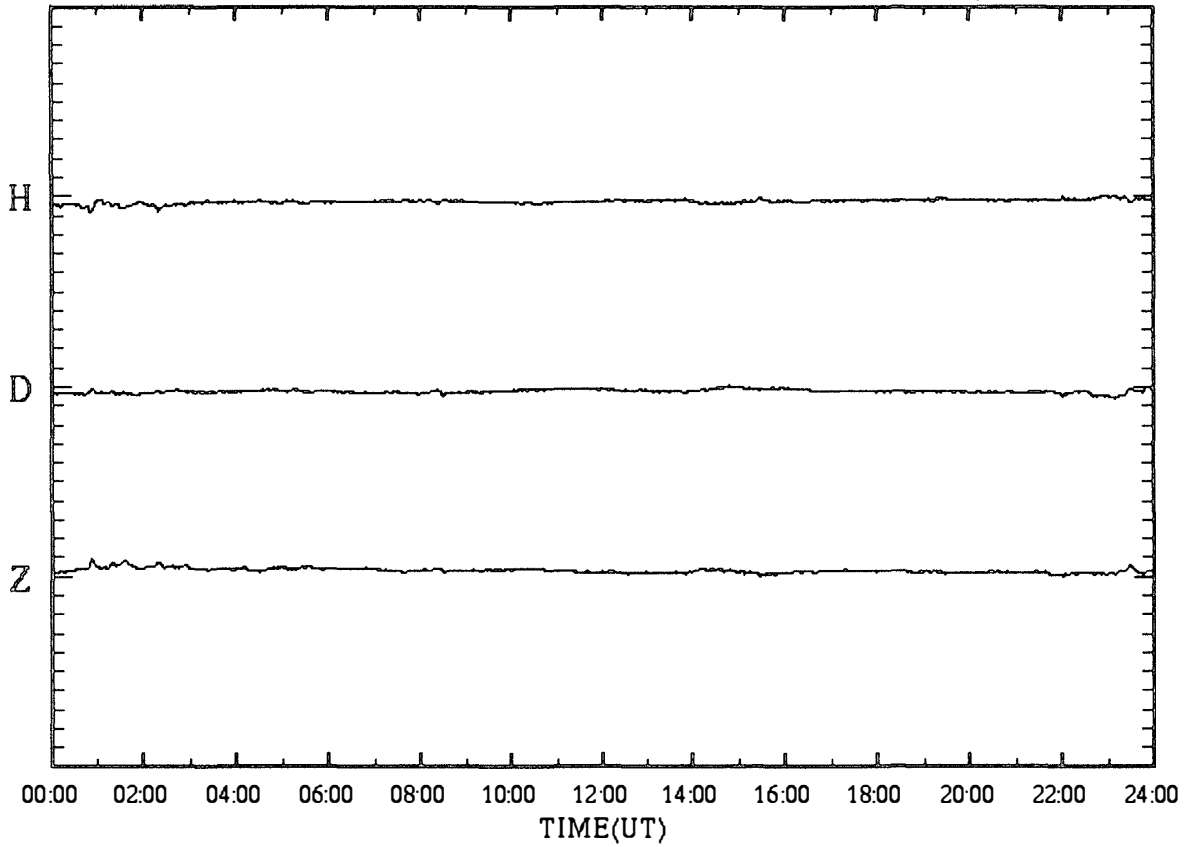

SYOWA magnetogram (100 nT/div)

12 Jul.1997 (DAY:193)

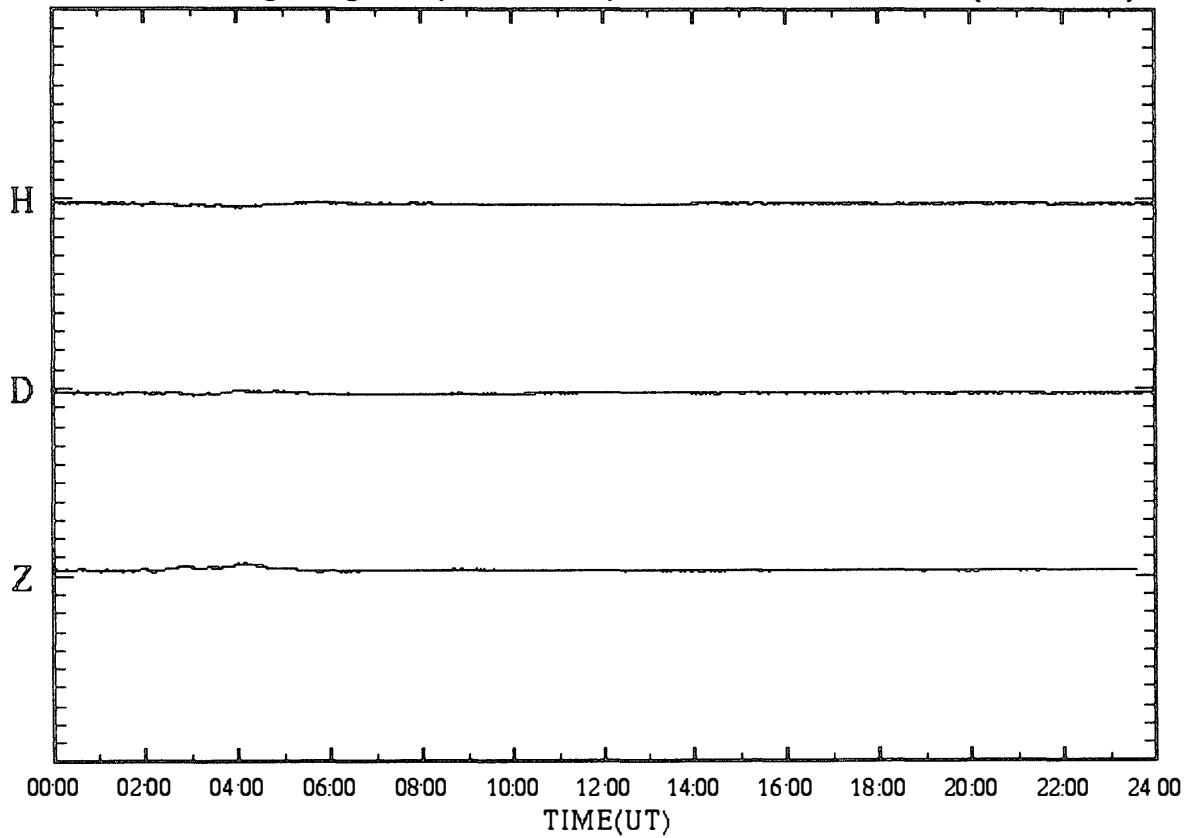

SYOWA magnetogram (100 nT/div)

13 Jul.1997 (DAY:194)

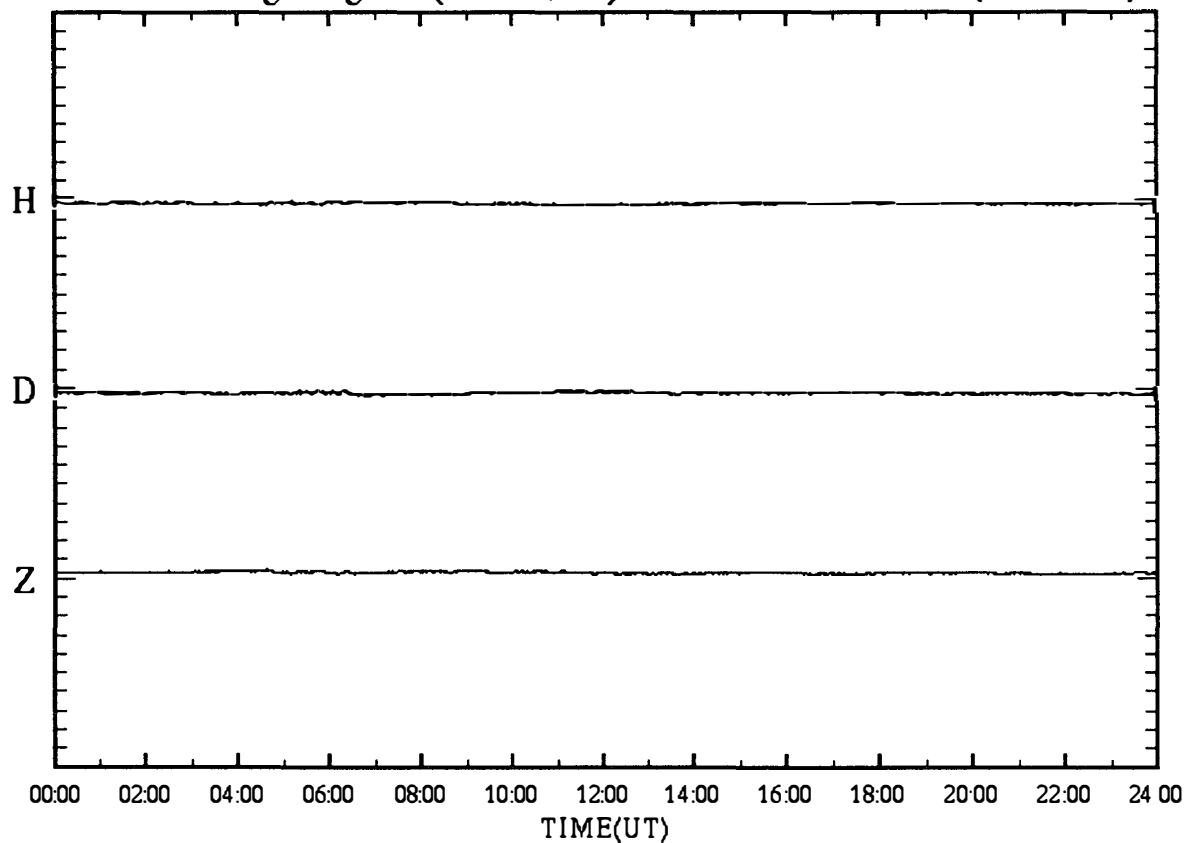

SYOWA magnetogram (100 nT/div)

14 Jul.1997 (DAY:195)

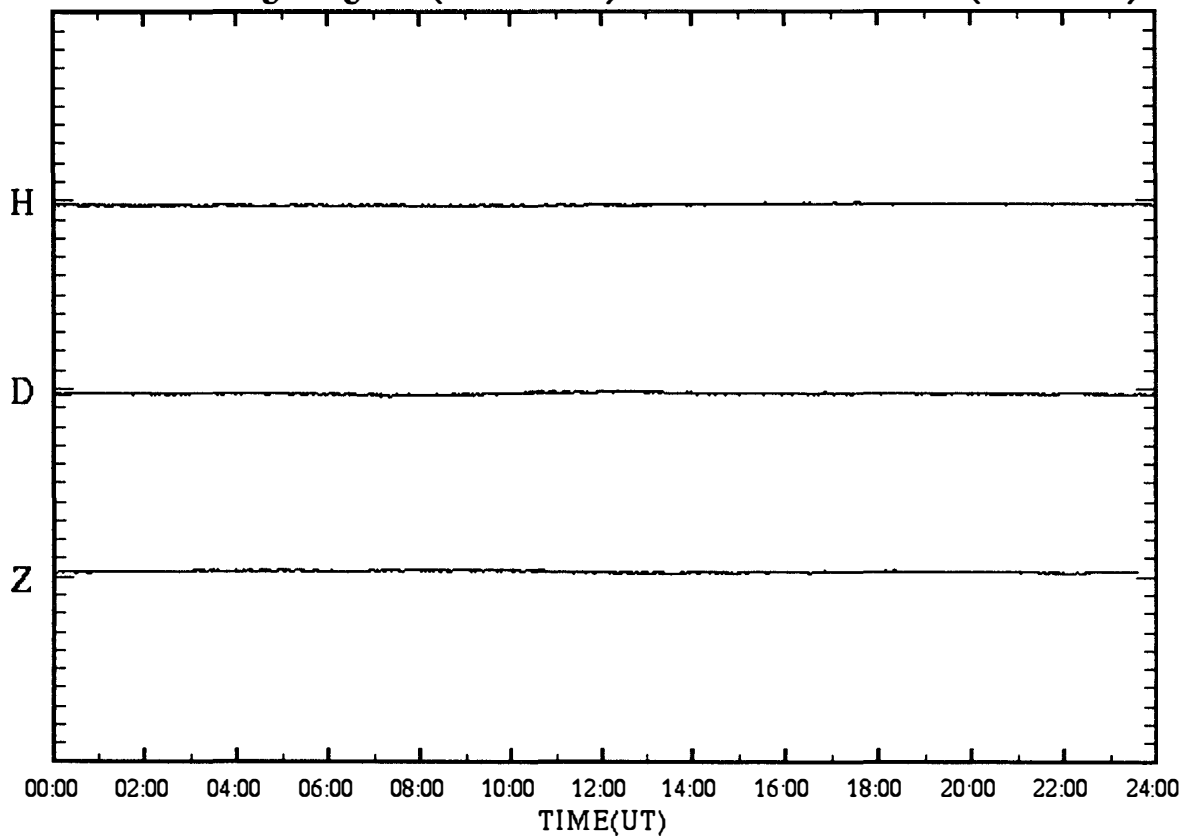

SYOWA magnetogram (100 nT/div)

15 Jul.1997 (DAY:196)

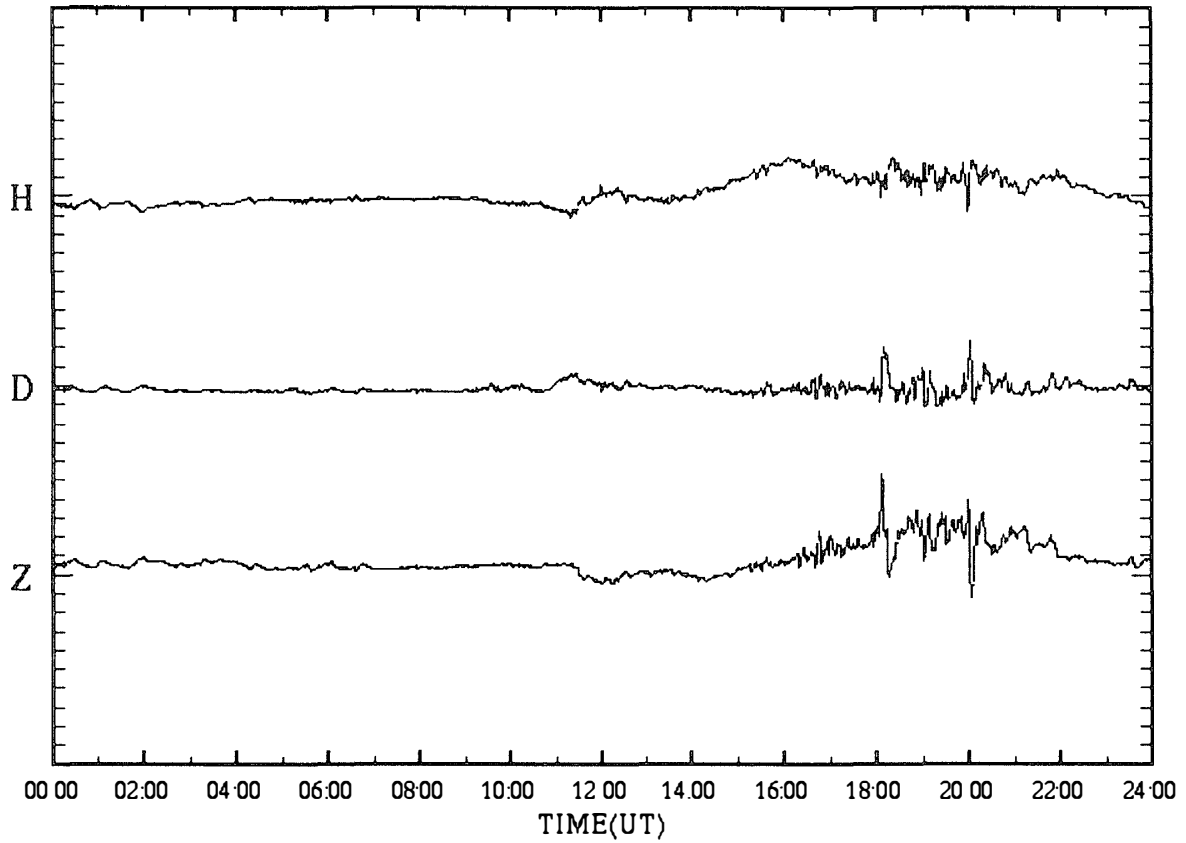

SYOWA magnetogram (100 nT/div)

16 Jul.1997 (DAY:197)

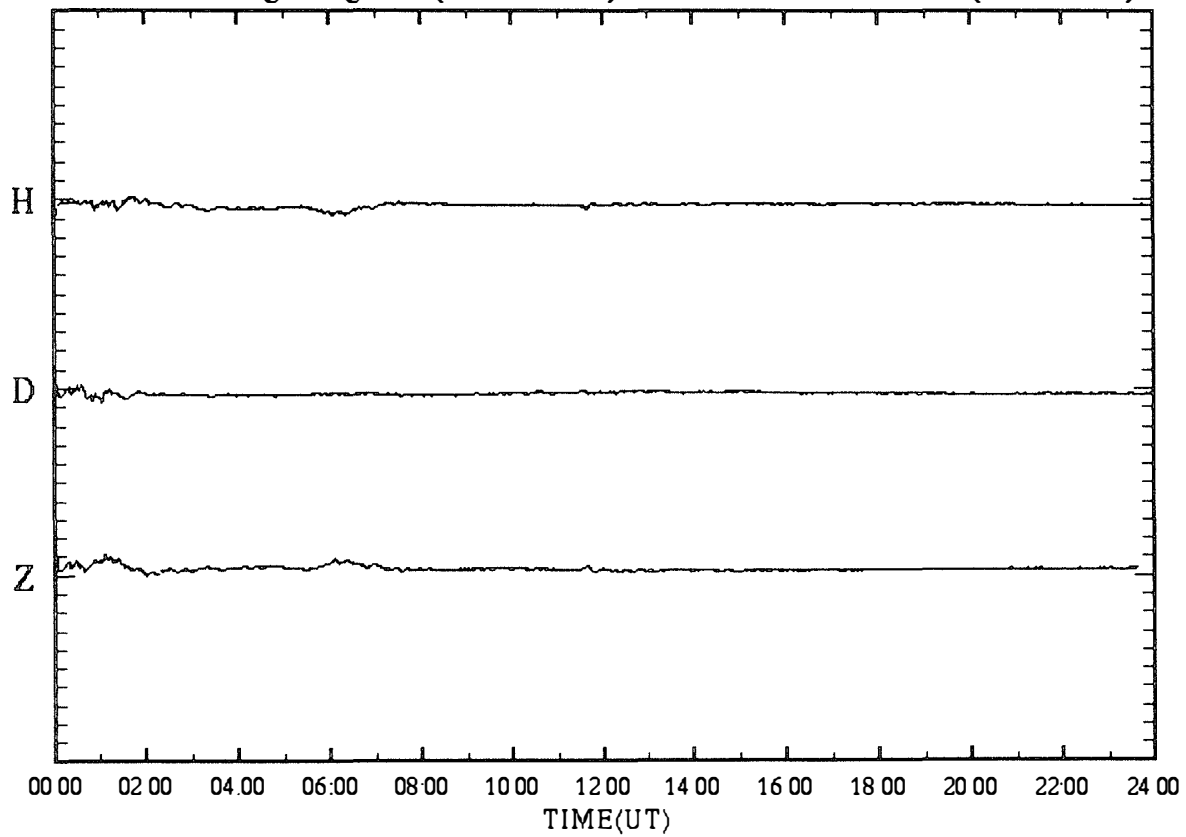



SYOWA magnetogram (100 nT/div)

17 Jul.1997 (DAY:198)

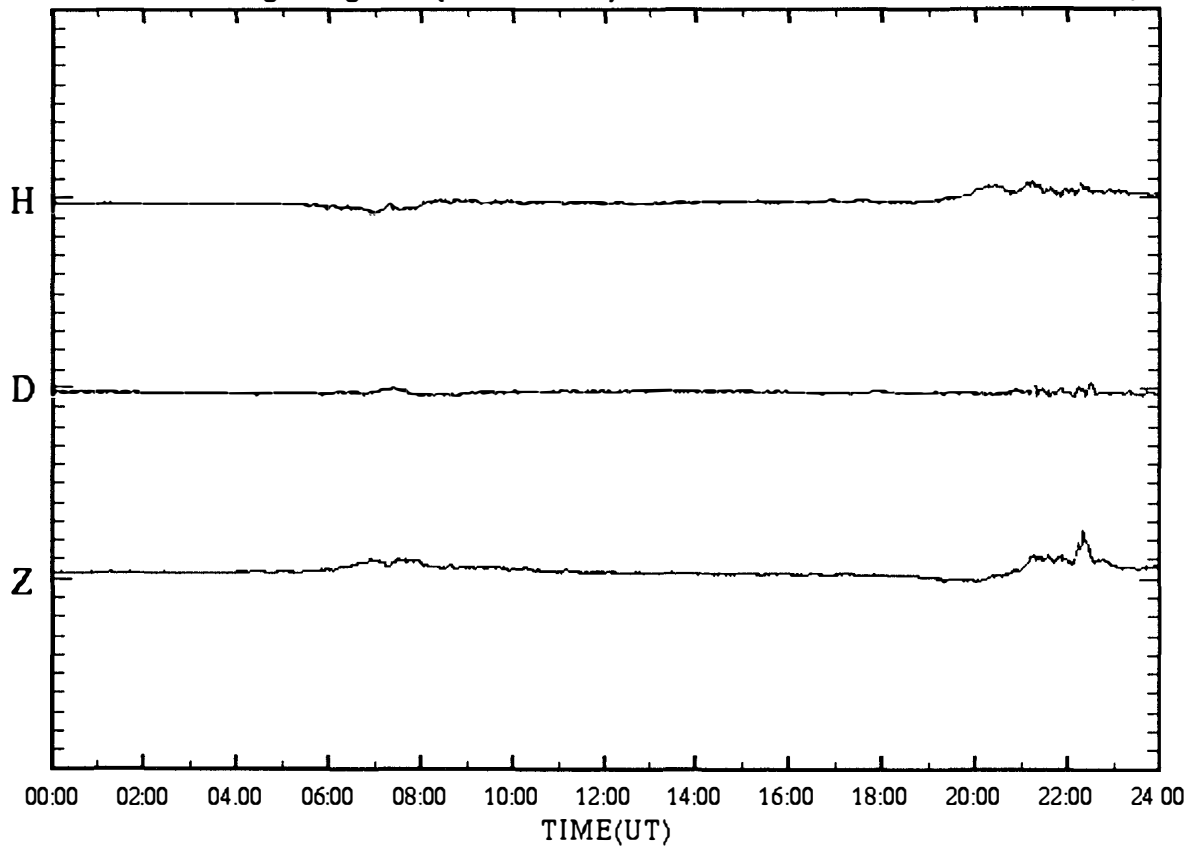

SYOWA magnetogram (100 nT/div)

18 Jul.1997 (DAY:199)

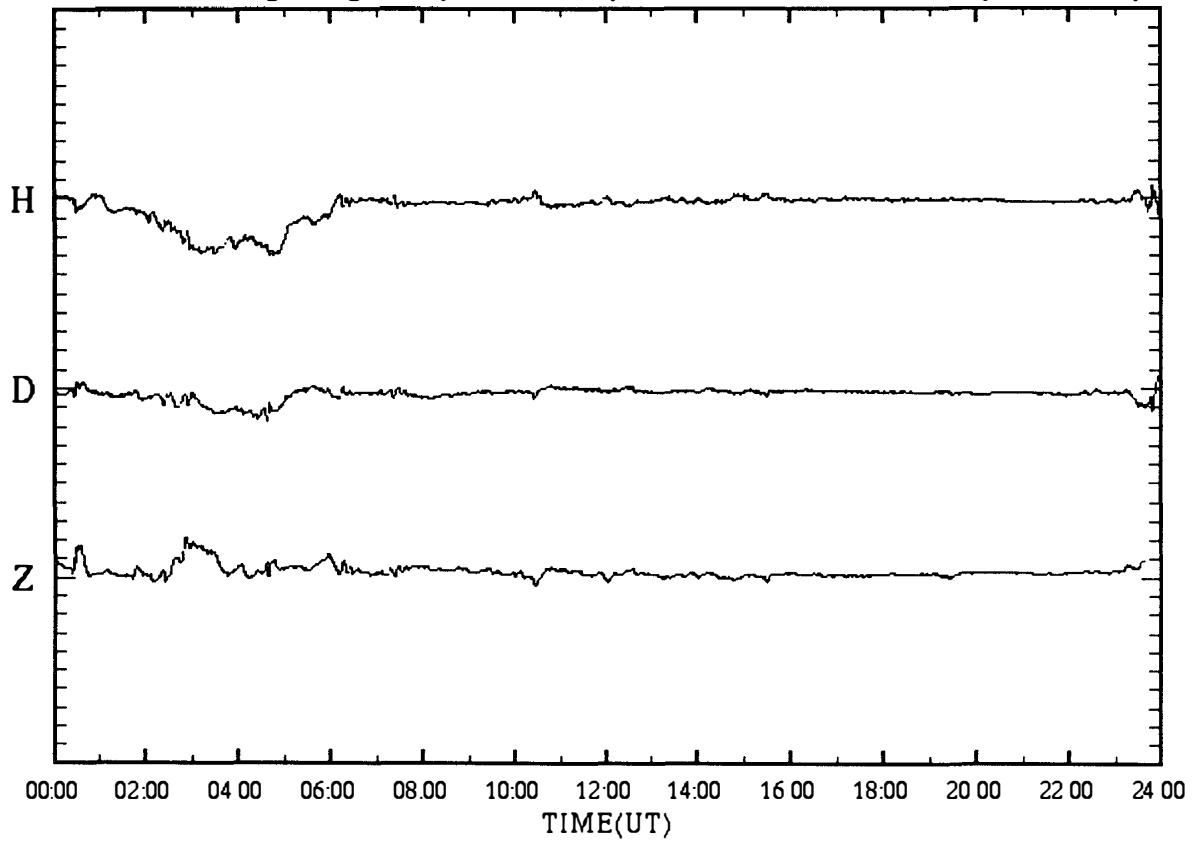

SYOWA magnetogram (100 nT/div)

19 Jul.1997 (DAY:200)

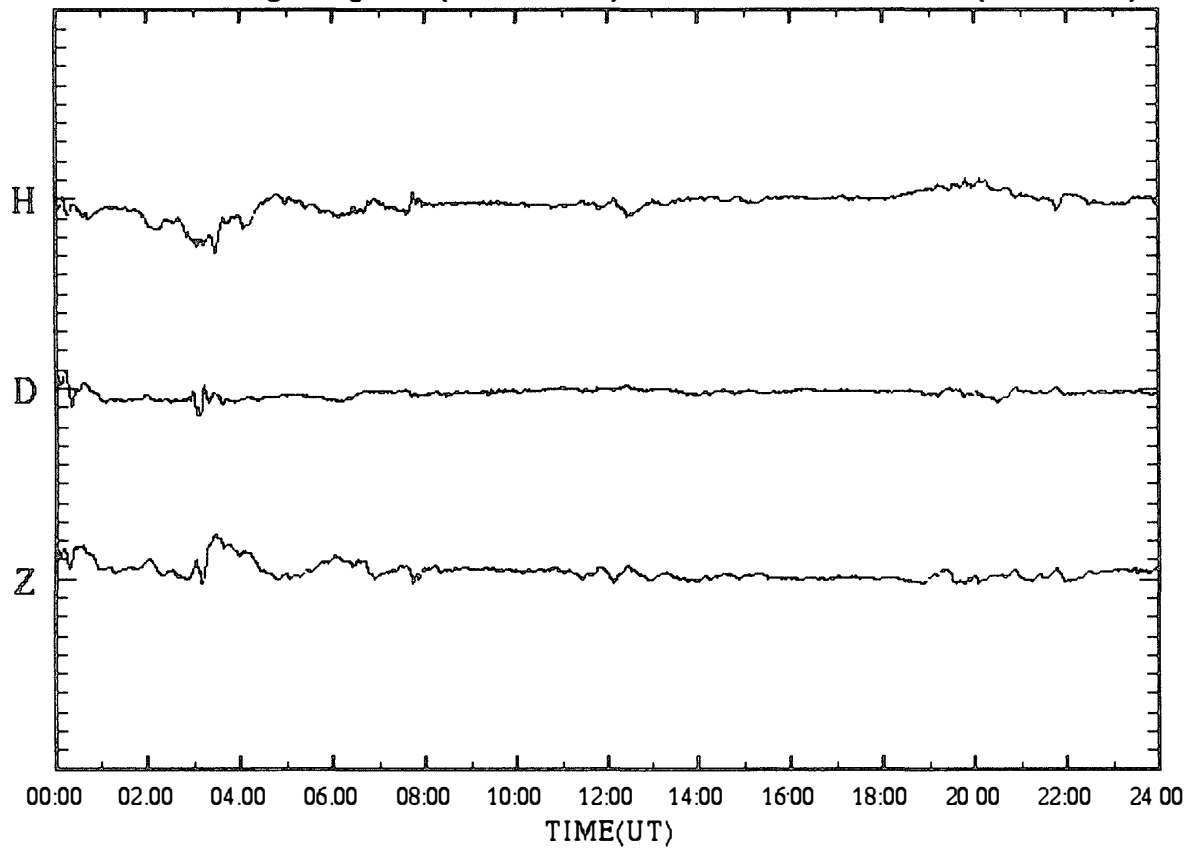

SYOWA magnetogram (100 nT/div)

20 Jul.1997 (DAY:201)

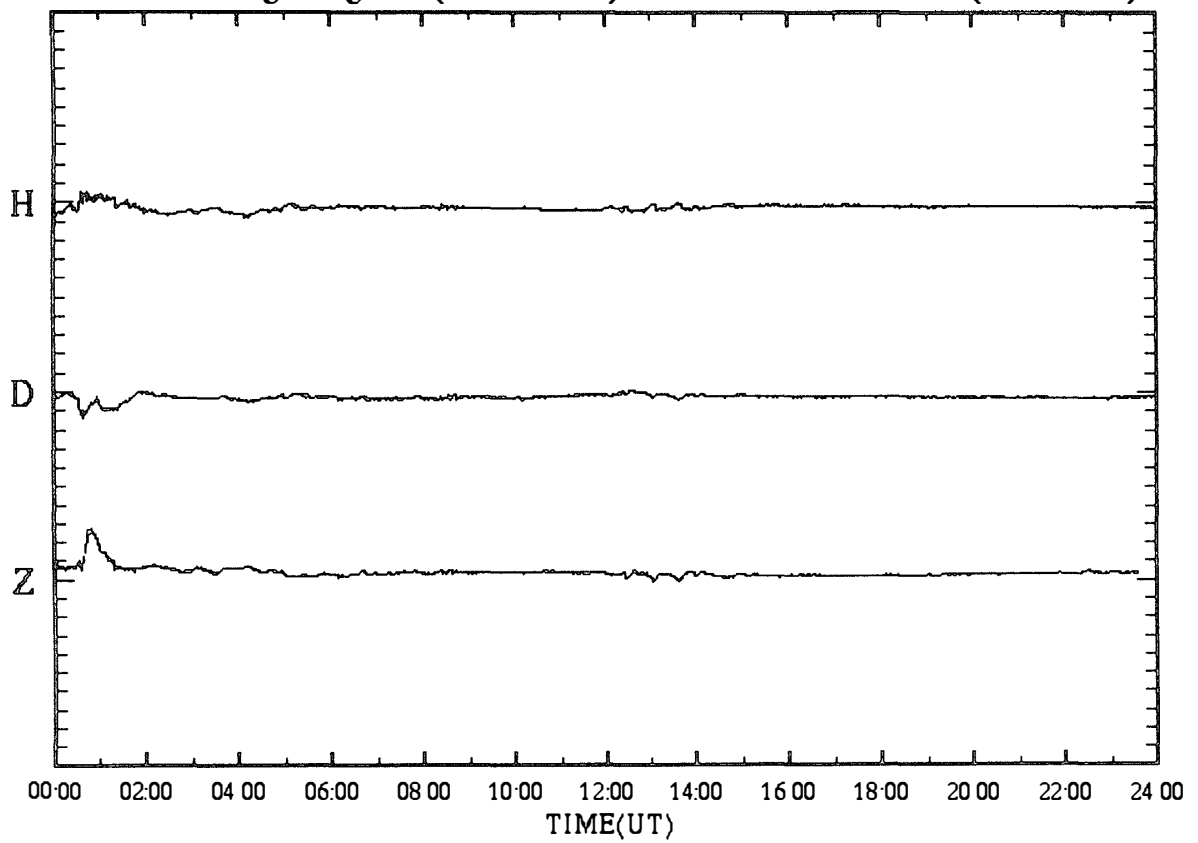

SYOWA magnetogram (100 nT/div)

21 Jul.1997 (DAY:202)

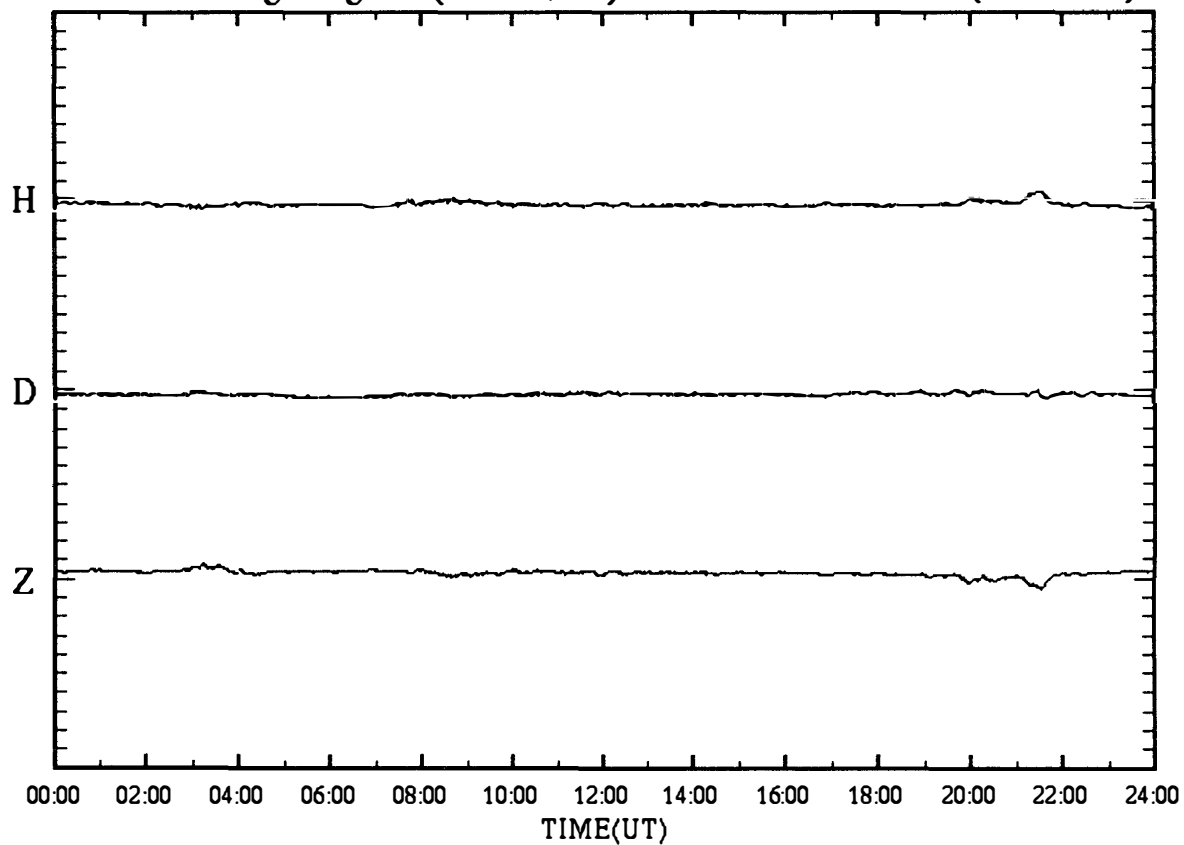

SYOWA magnetogram (100 nT/div)

22 Jul.1997 (DAY:203)

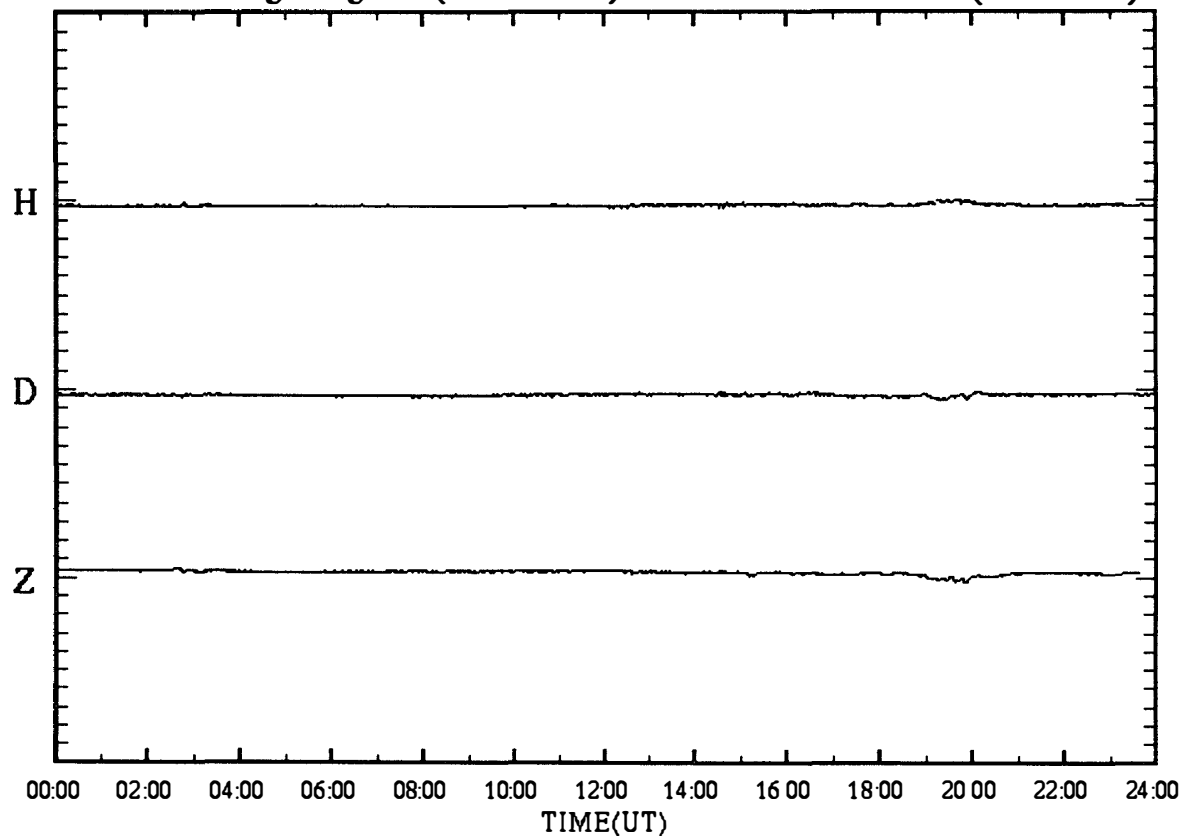

SYOWA magnetogram (100 nT/div)

23 Jul.1997 (DAY:204)

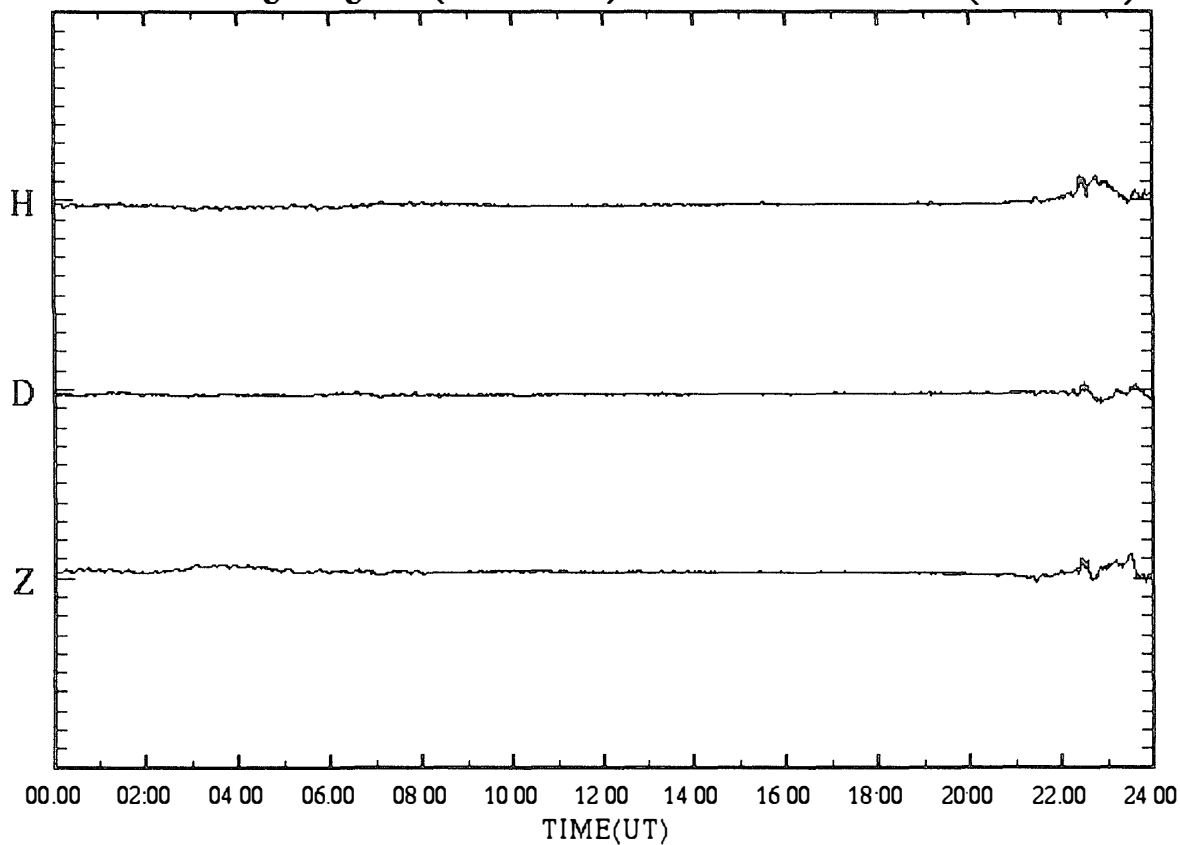

SYOWA magnetogram (100 nT/div)

24 Jul.1997 (DAY:205)

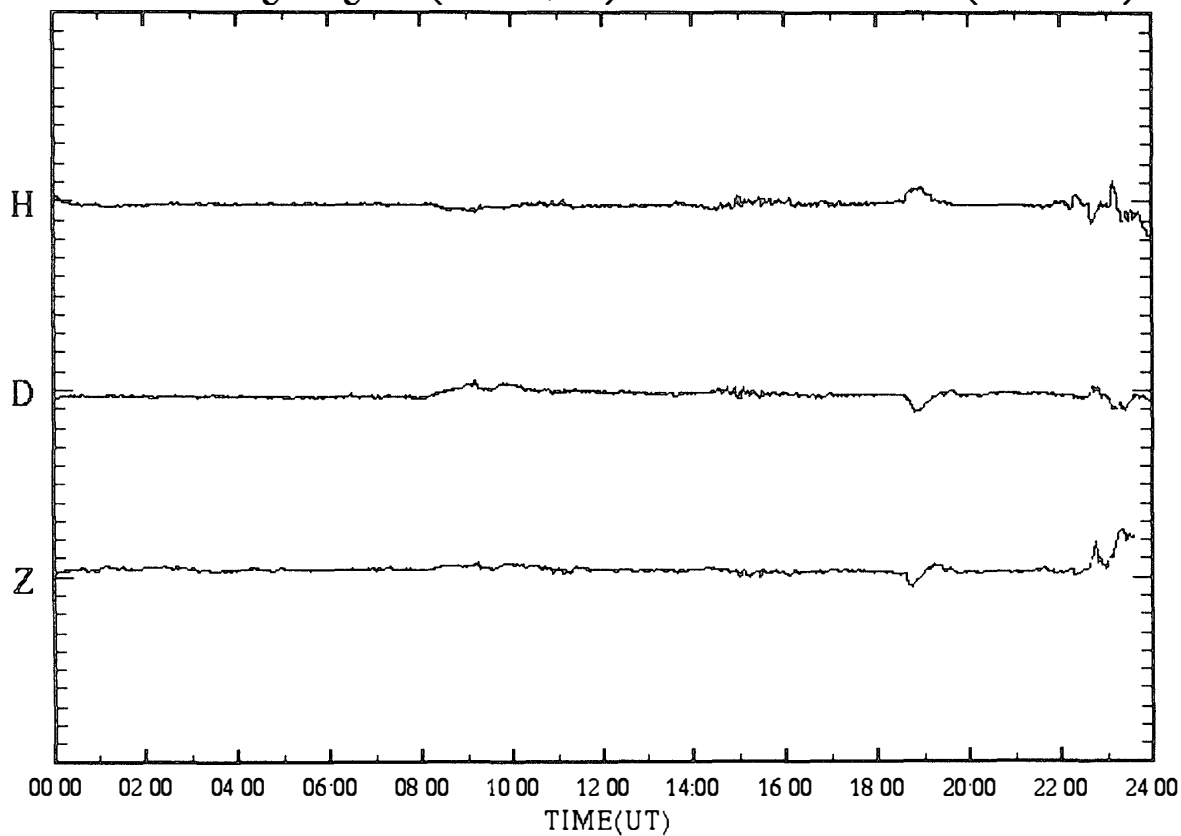

SYOWA magnetogram (100 nT/div)

25 Jul.1997 (DAY:206)

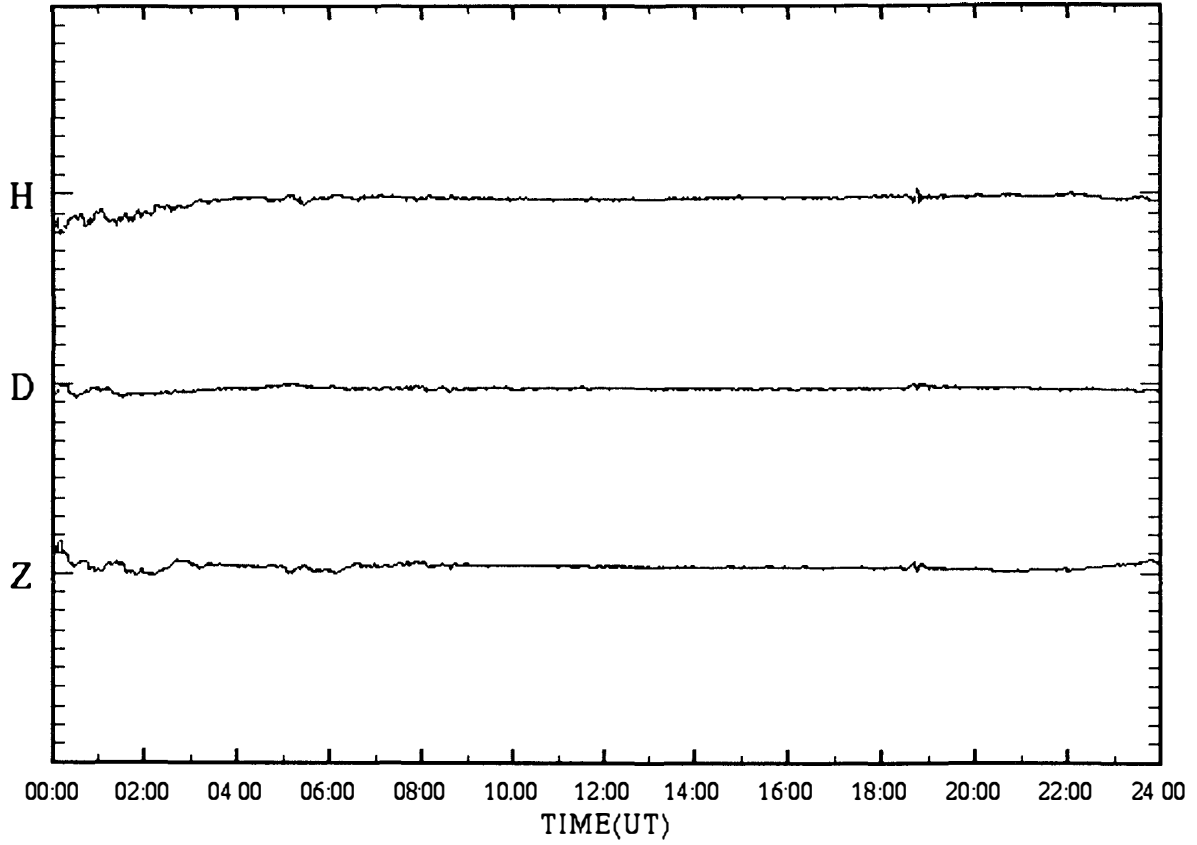

SYOWA magnetogram (100 nT/div)

26 Jul.1997 (DAY:207)

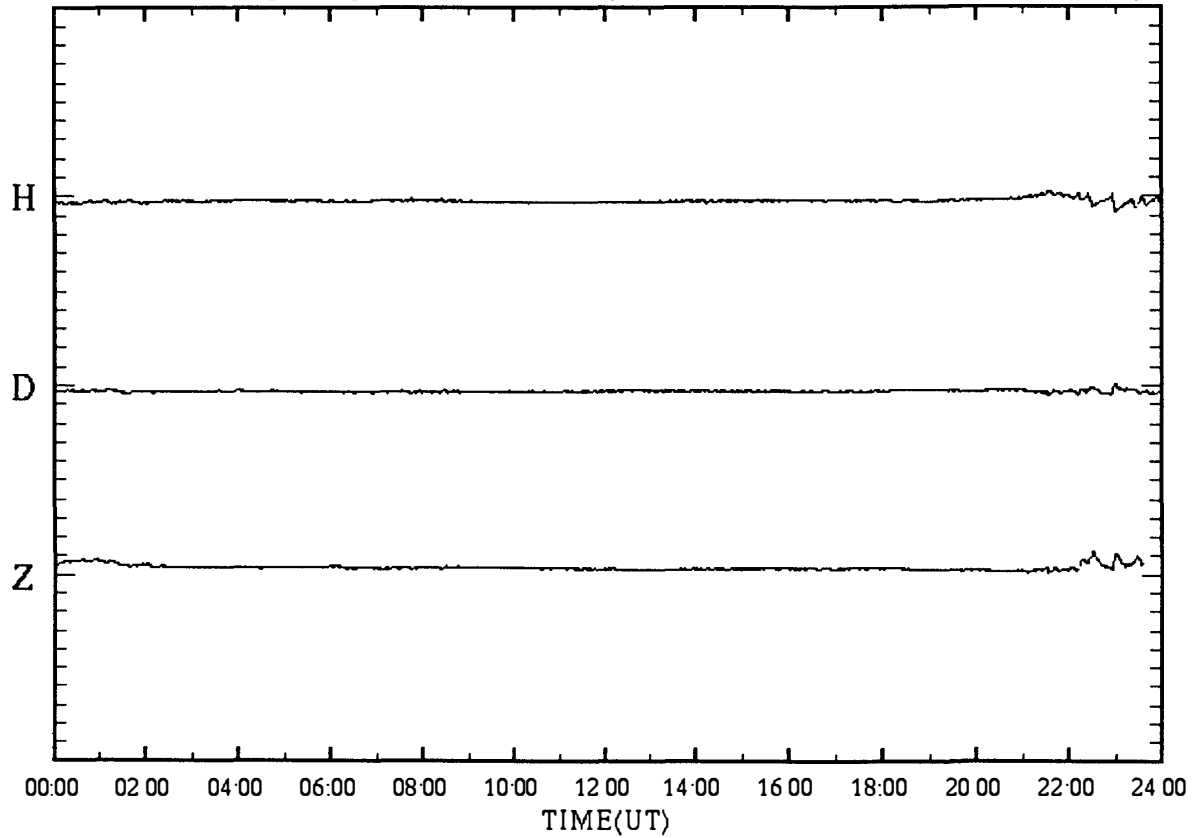

SYOWA magnetogram (100 nT/div)

27 Jul.1997 (DAY:208)

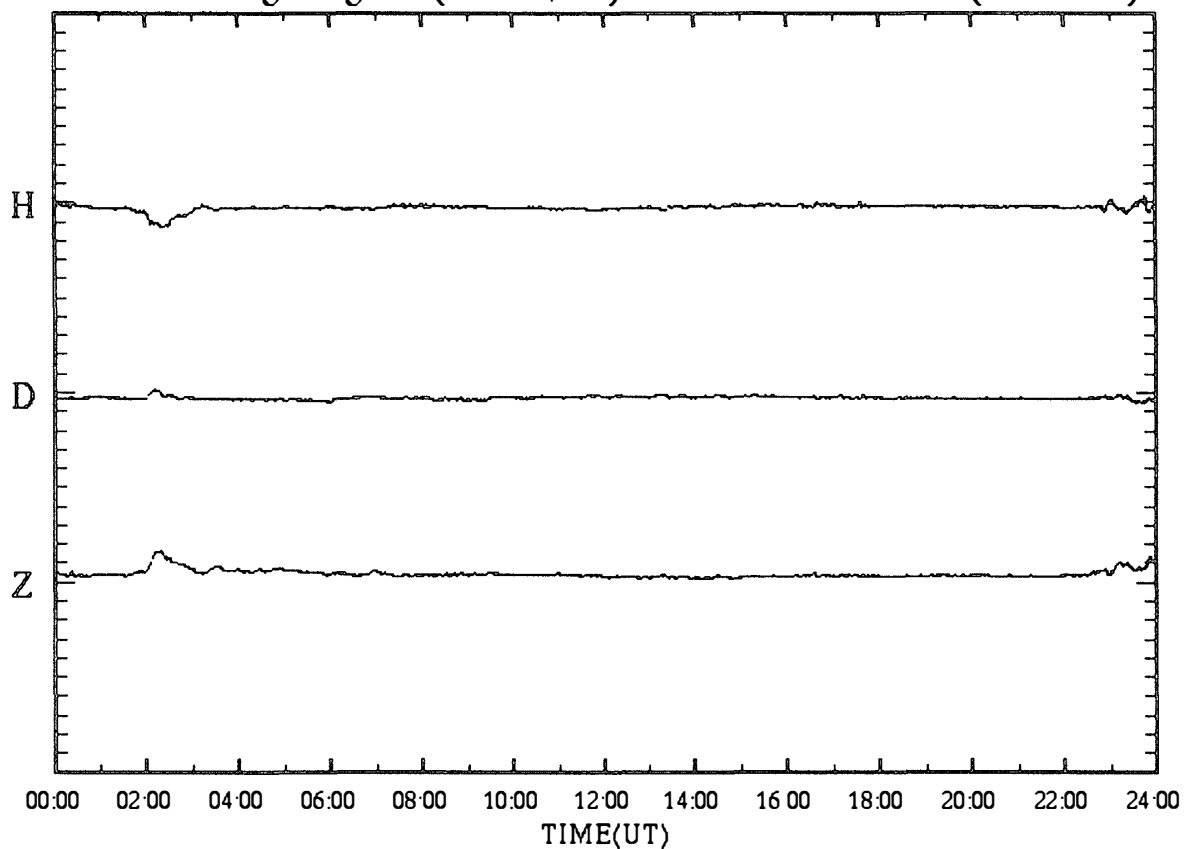

SYOWA magnetogram (100 nT/div)

28 Jul.1997 (DAY:209)

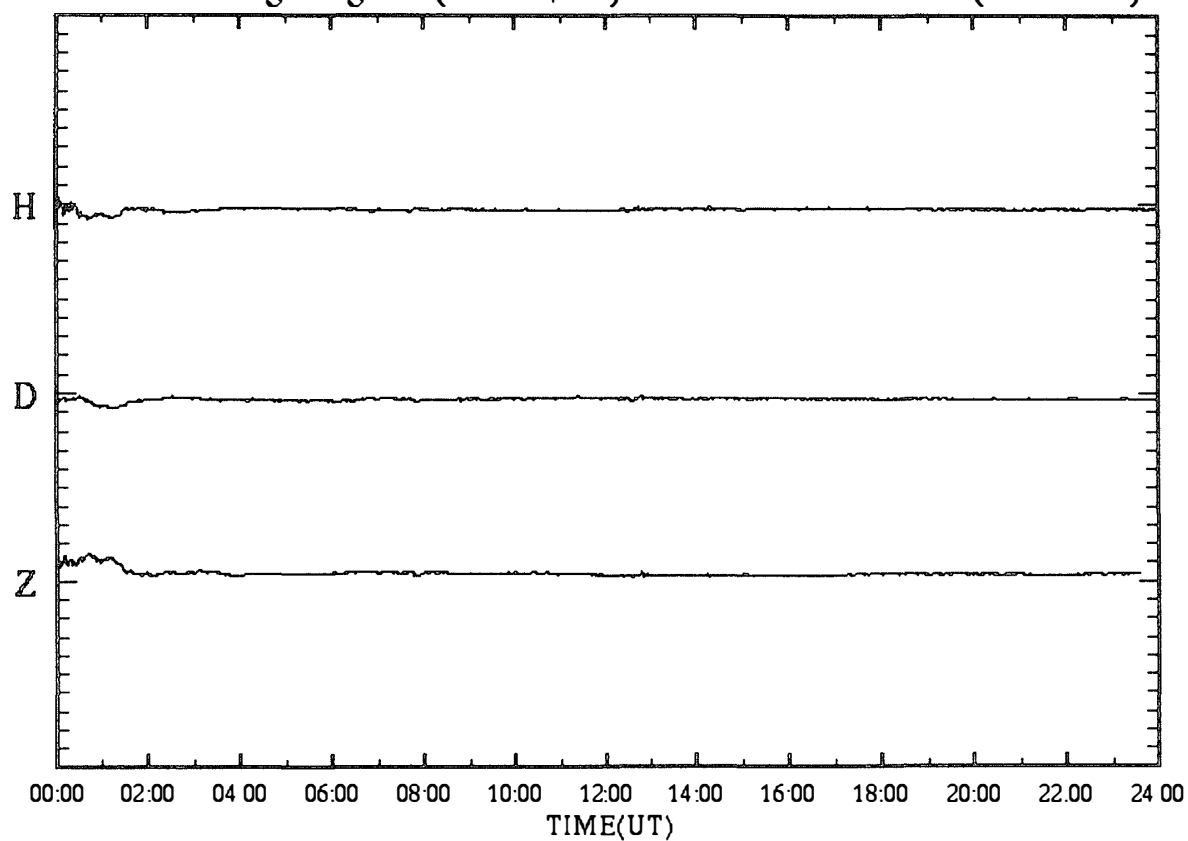

SYOWA magnetogram (100 nT/div)

29 Jul.1997 (DAY:210)

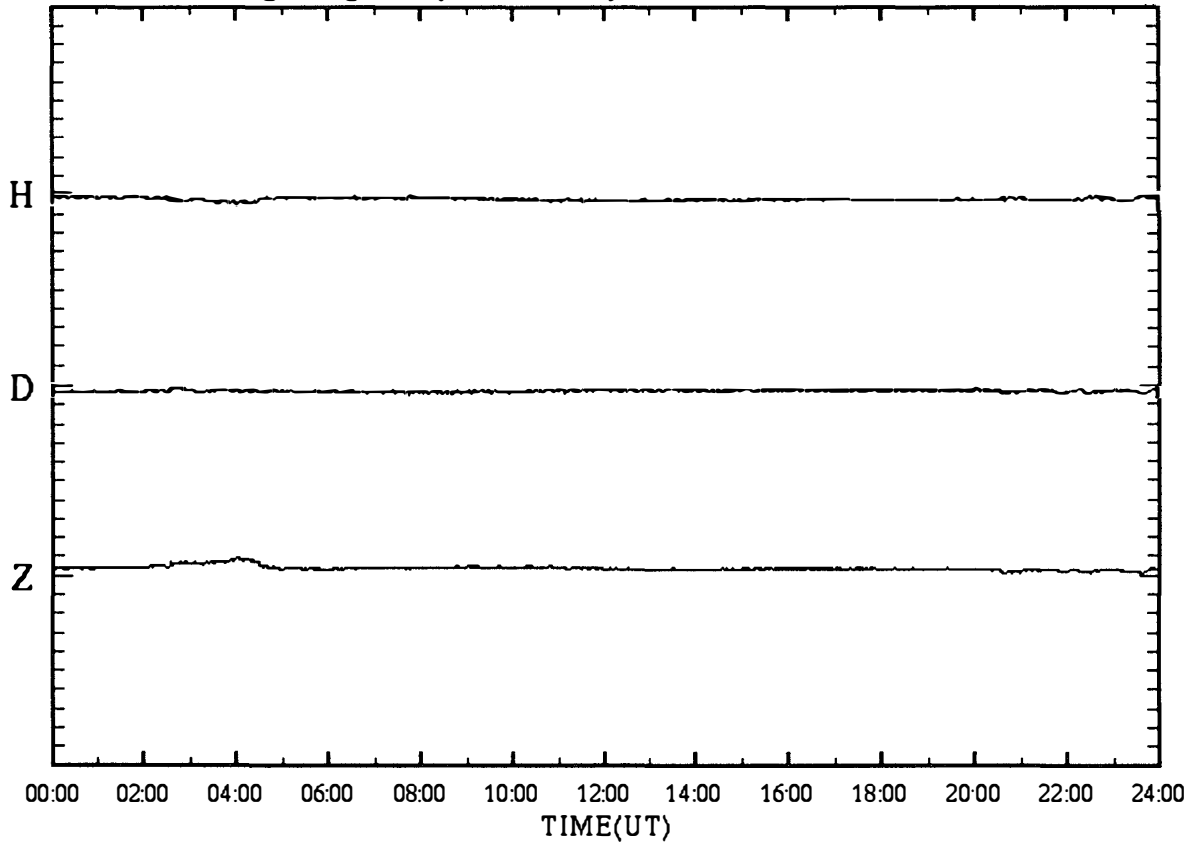

SYOWA magnetogram (100 nT/div)

30 Jul.1997 (DAY:211)

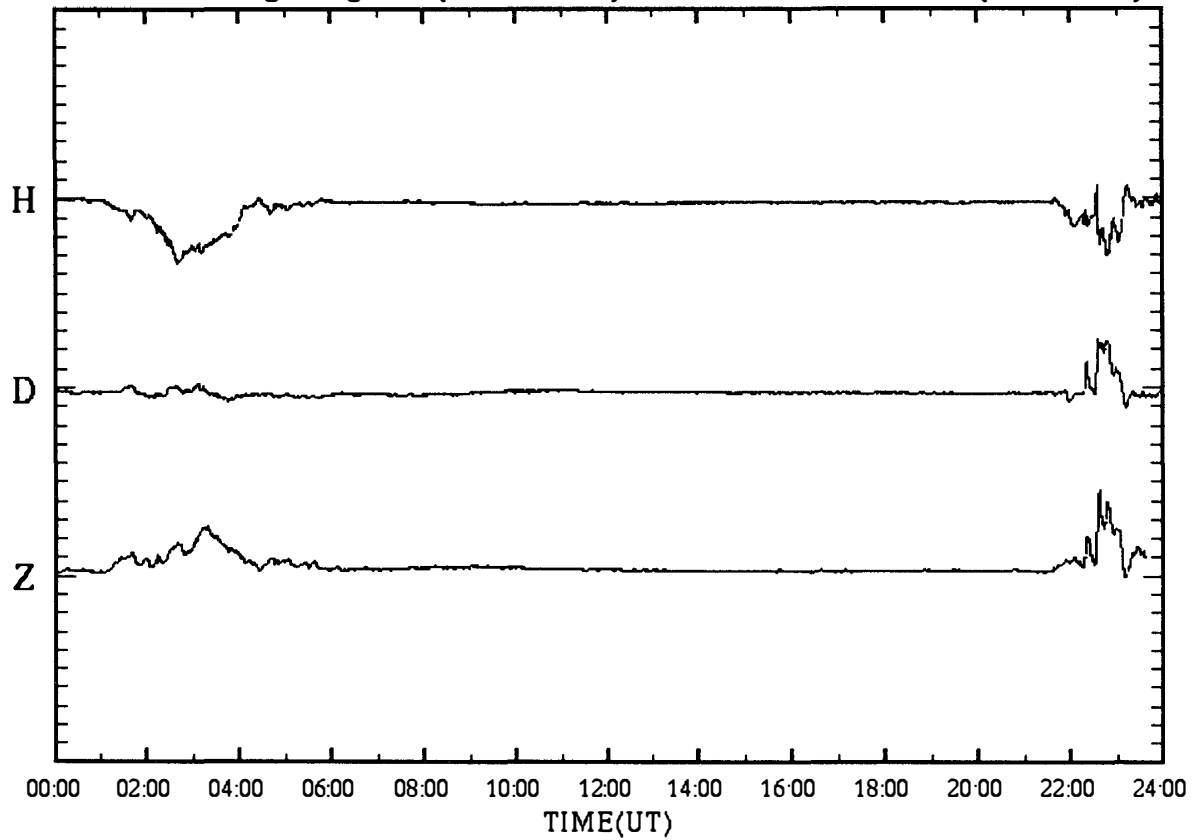

SYOWA magnetogram (100 nT/div)

31 Jul.1997 (DAY:212)

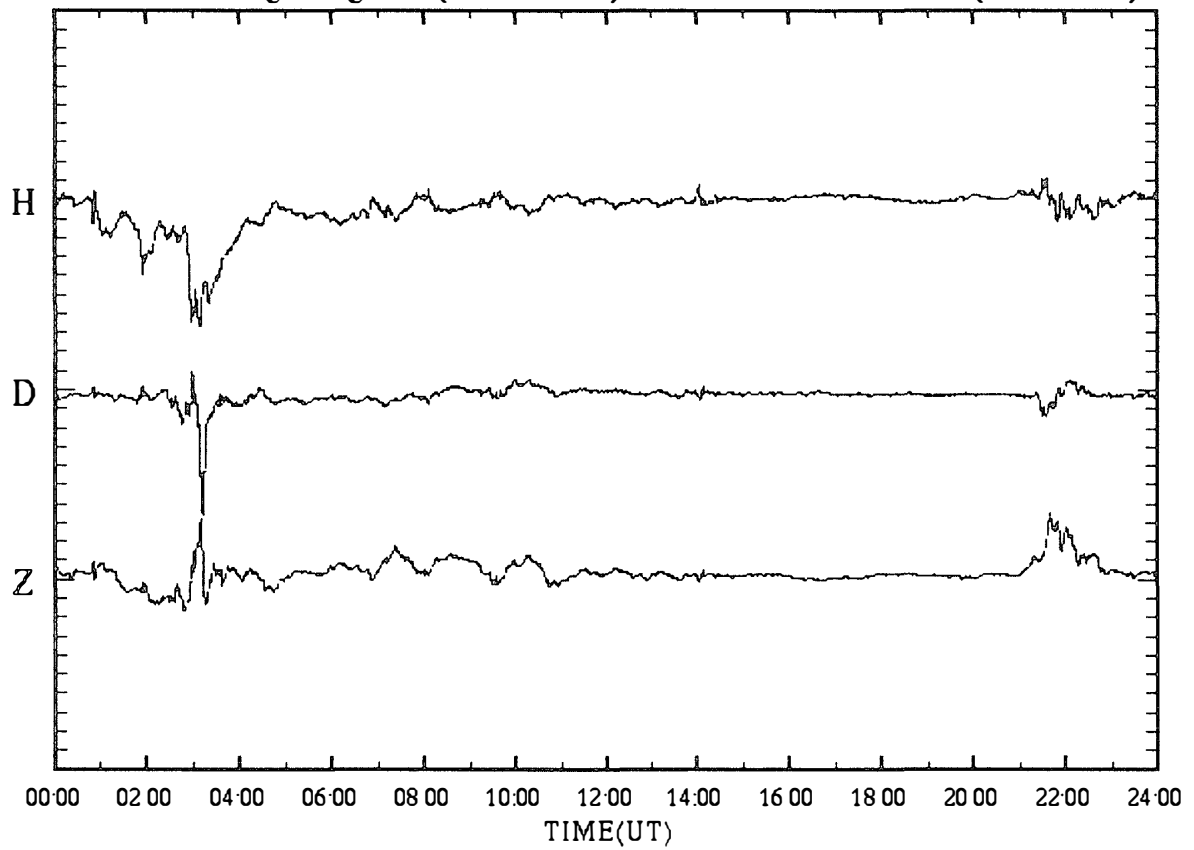

SYOWA magnetogram (100 nT/div)

01 Aug.1997 (DAY:213)

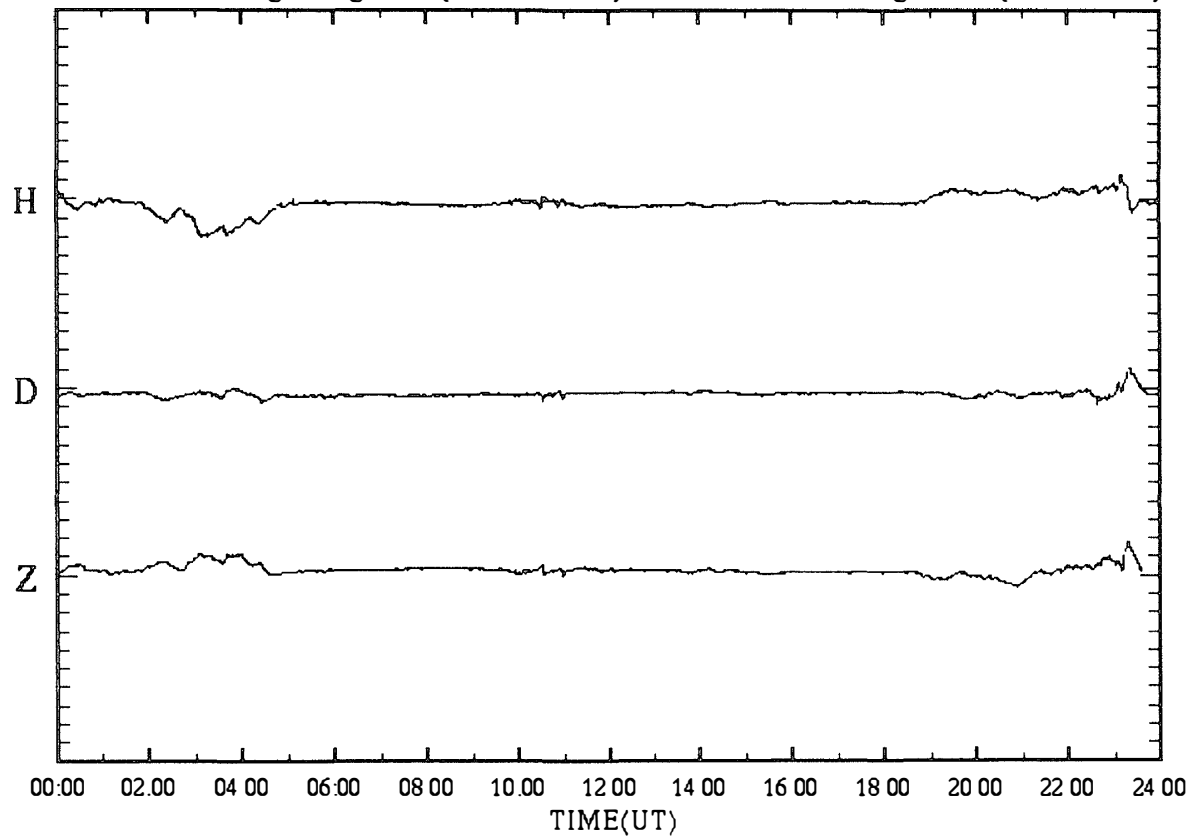



SYOWA magnetogram (100 nT/div)

02 Aug.1997 (DAY:214)

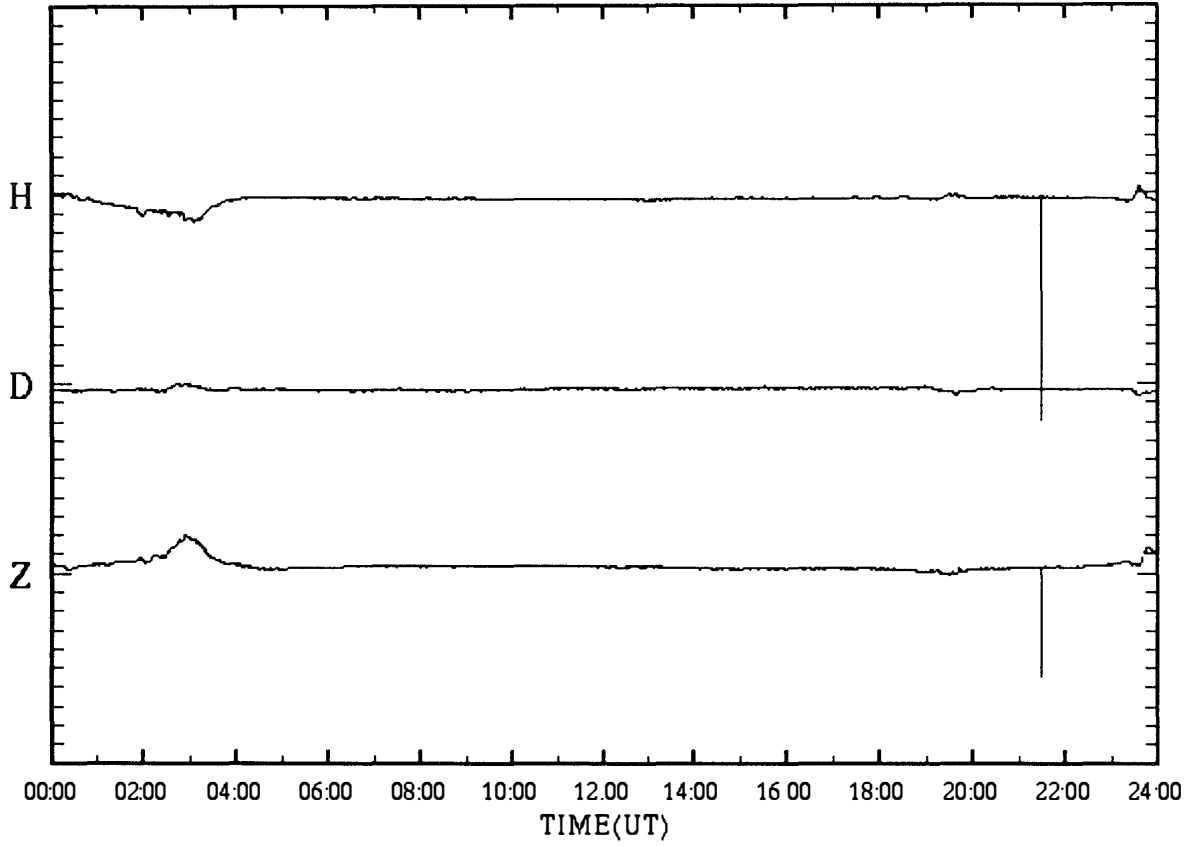

SYOWA magnetogram (100 nT/div)

03 Aug.1997 (DAY:215)

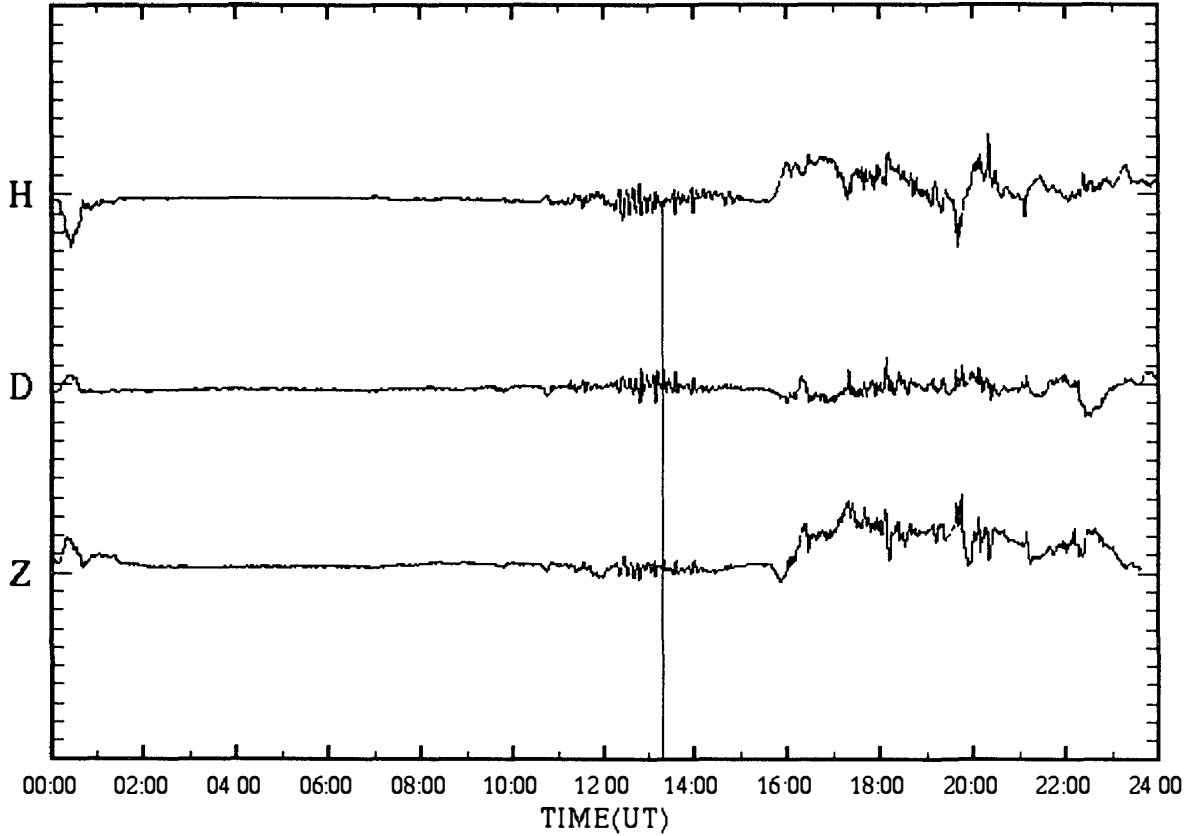

SYOWA magnetogram (100 nT/div)

04 Aug.1997 (DAY:216)

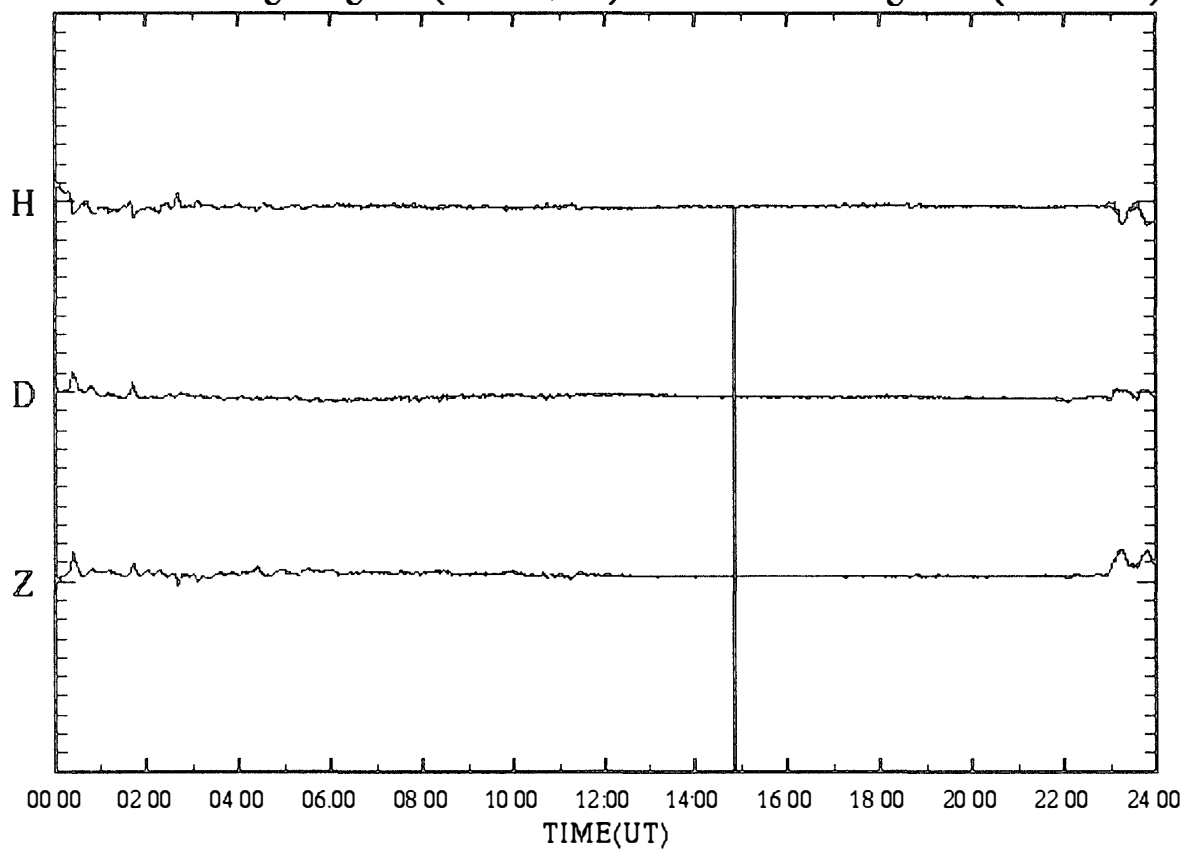

SYOWA magnetogram (100 nT/div)

05 Aug.1997 (DAY:217)

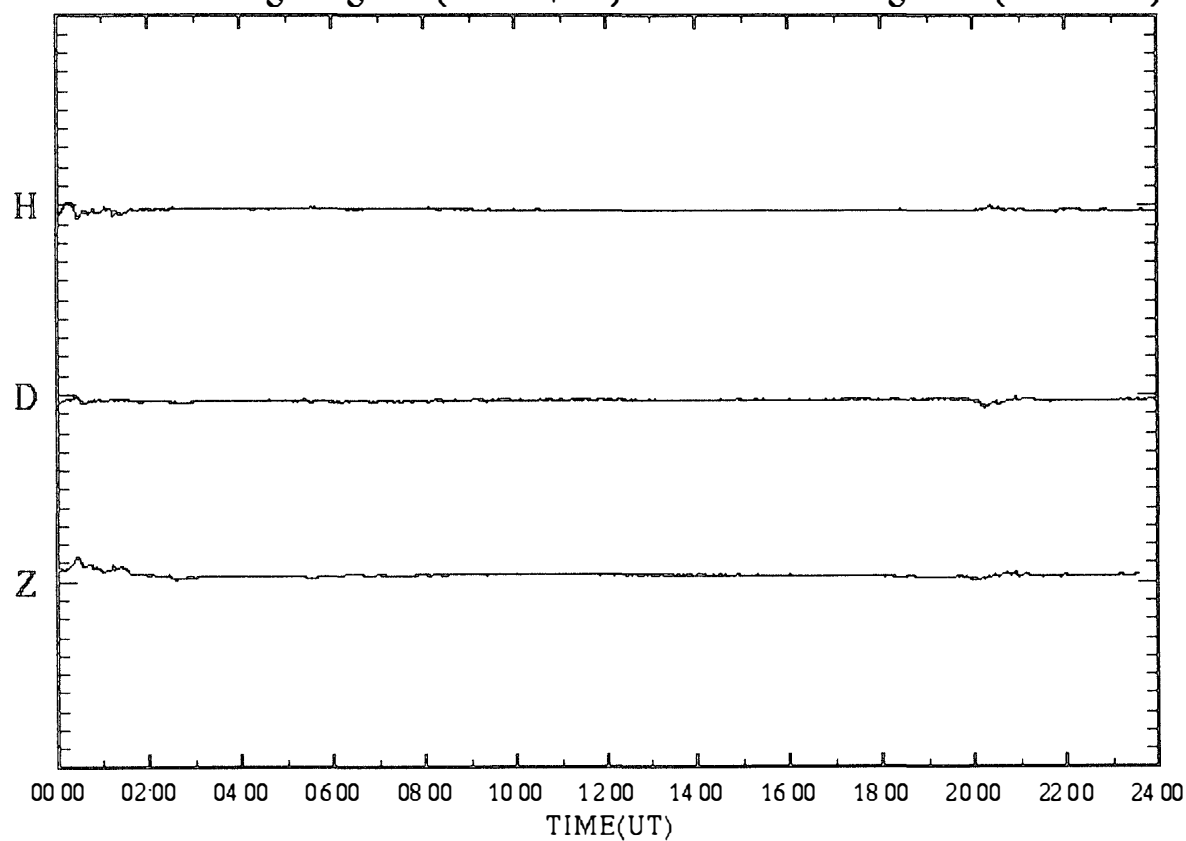

SYOWA magnetogram (100 nT/div)

06 Aug.1997 (DAY:218)

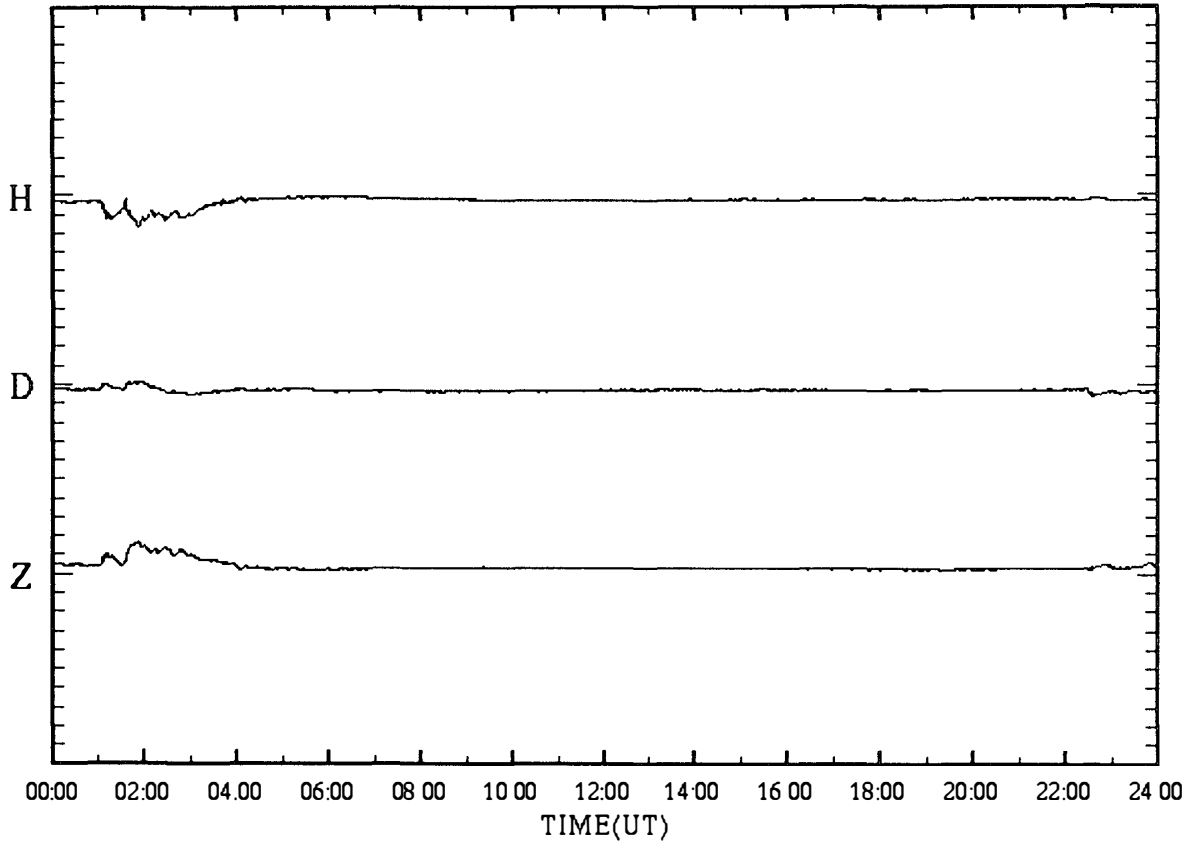

SYOWA magnetogram (100 nT/div)

07 Aug.1997 (DAY:219)

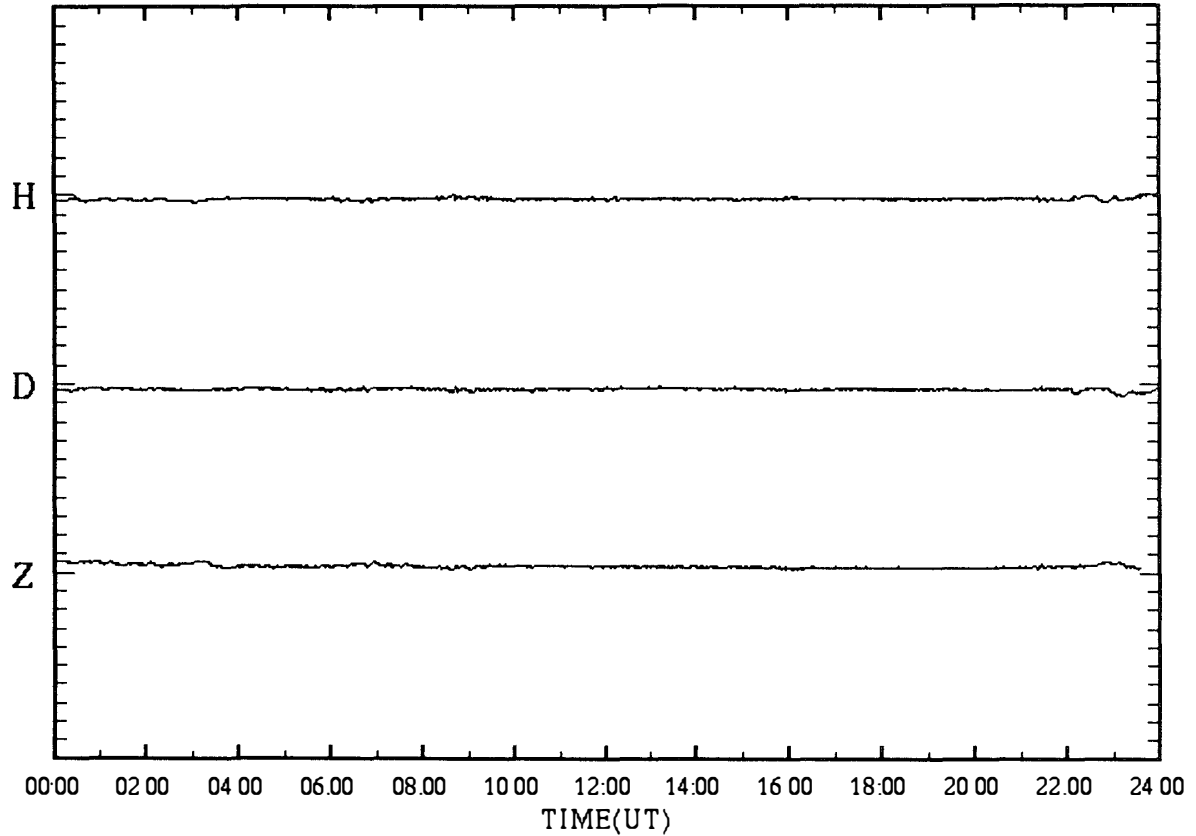

SYOWA magnetogram (100 nT/div)

08 Aug.1997 (DAY:220)

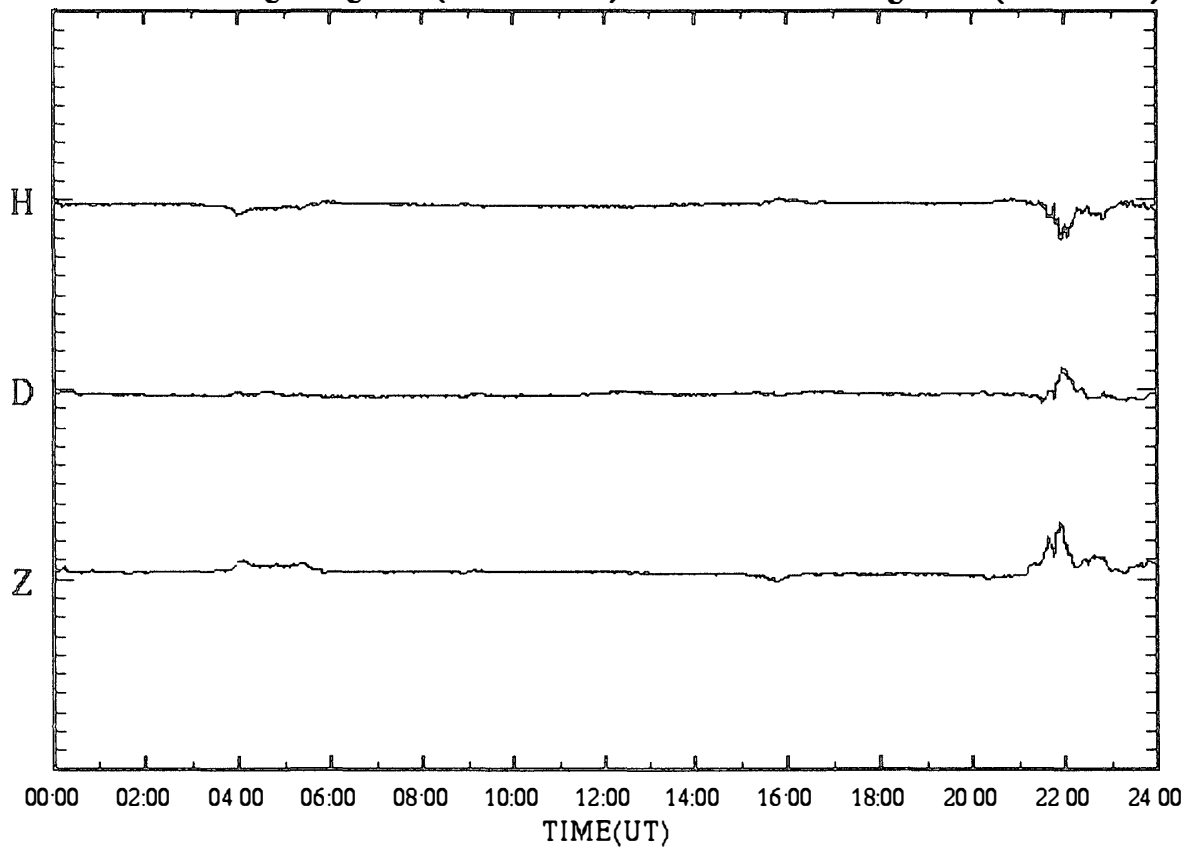

SYOWA magnetogram (100 nT/div)

09 Aug.1997 (DAY:221)

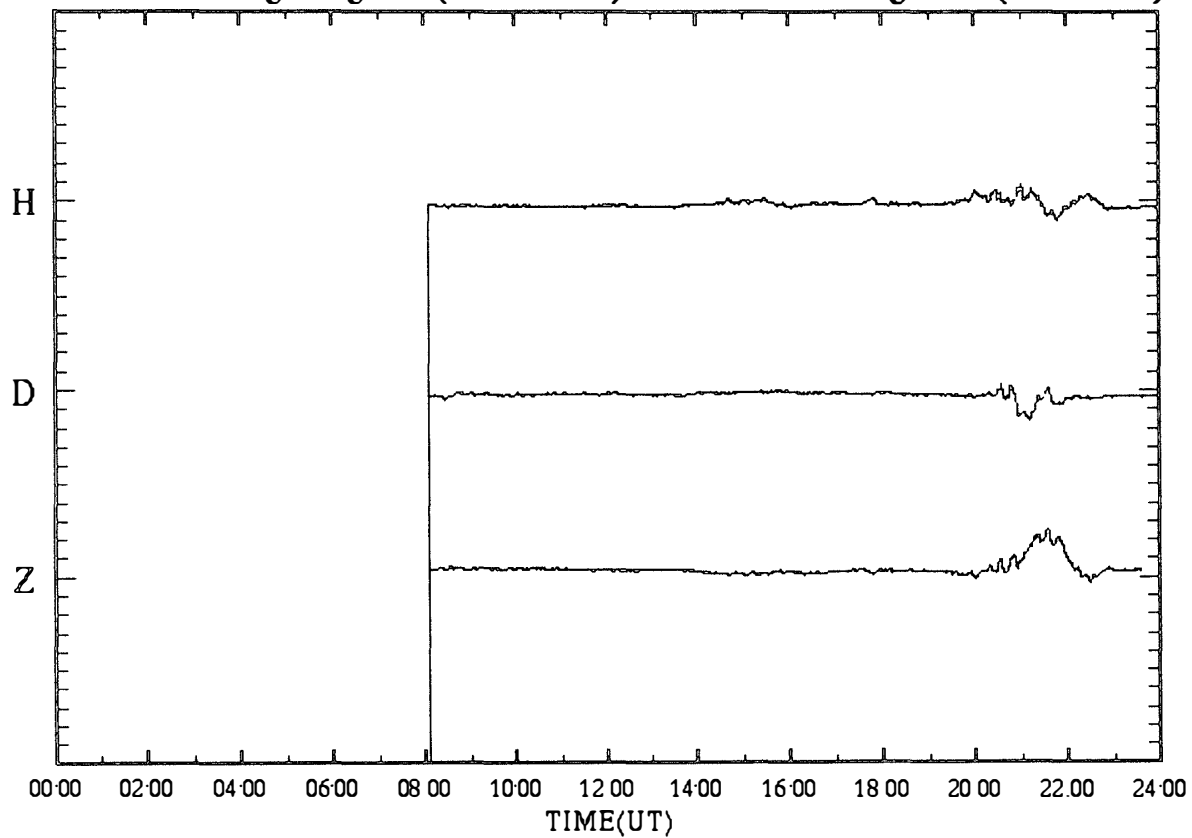

SYOWA magnetogram (100 nT/div)

10 Aug.1997 (DAY:222)

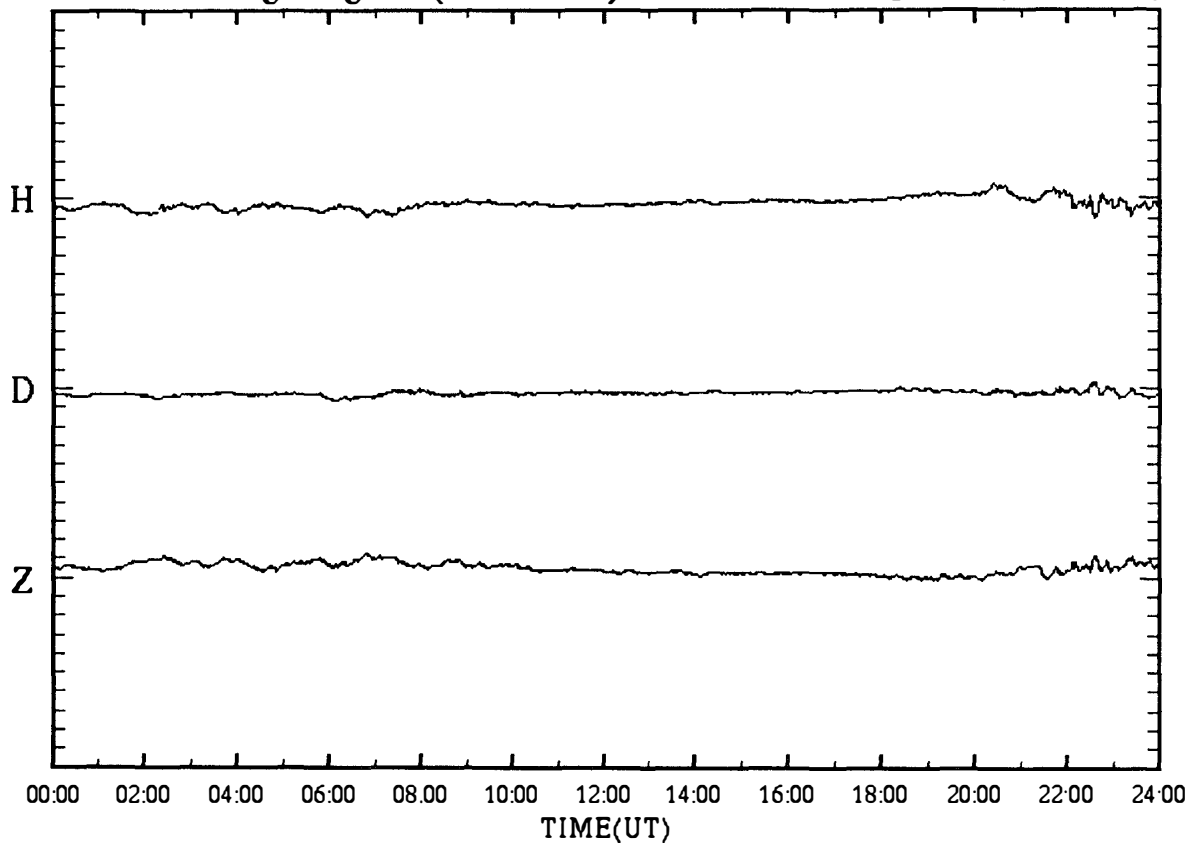

SYOWA magnetogram (100 nT/div)

11 Aug.1997 (DAY:223)

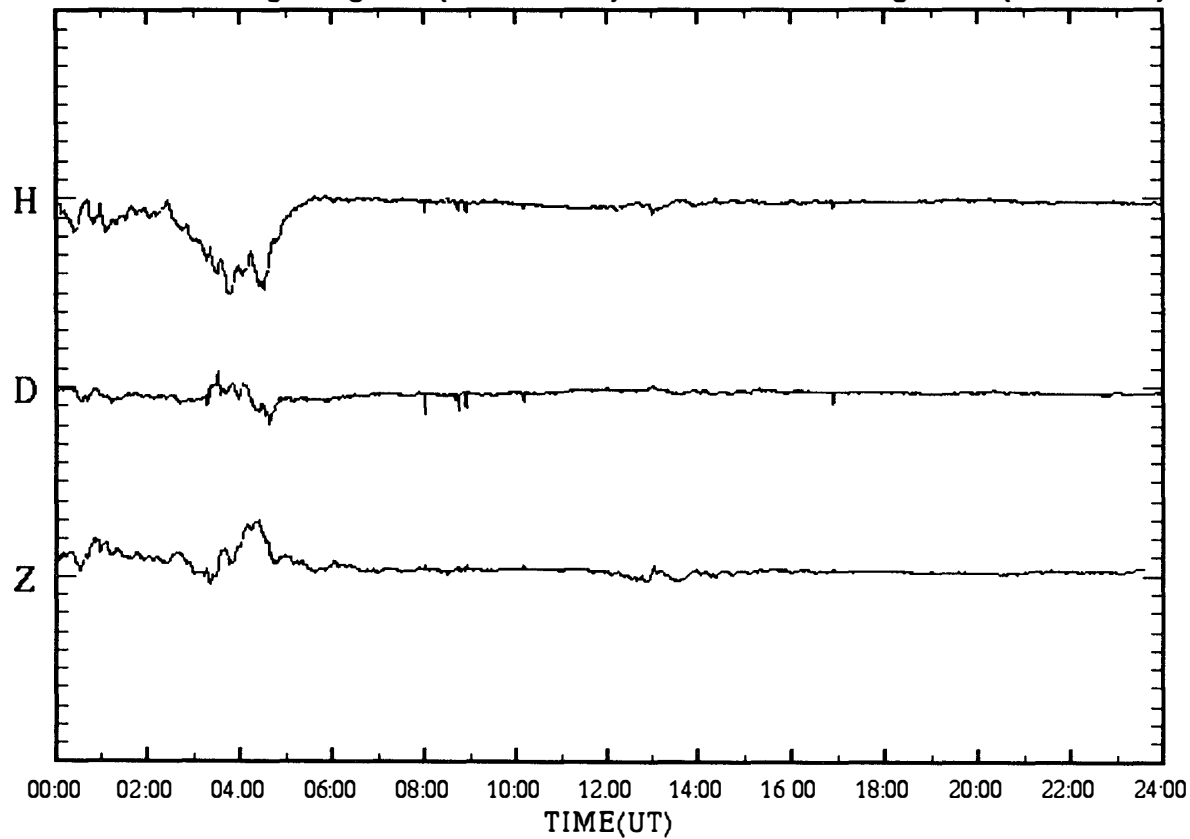

SYOWA magnetogram (100 nT/div)

12 Aug.1997 (DAY:224)

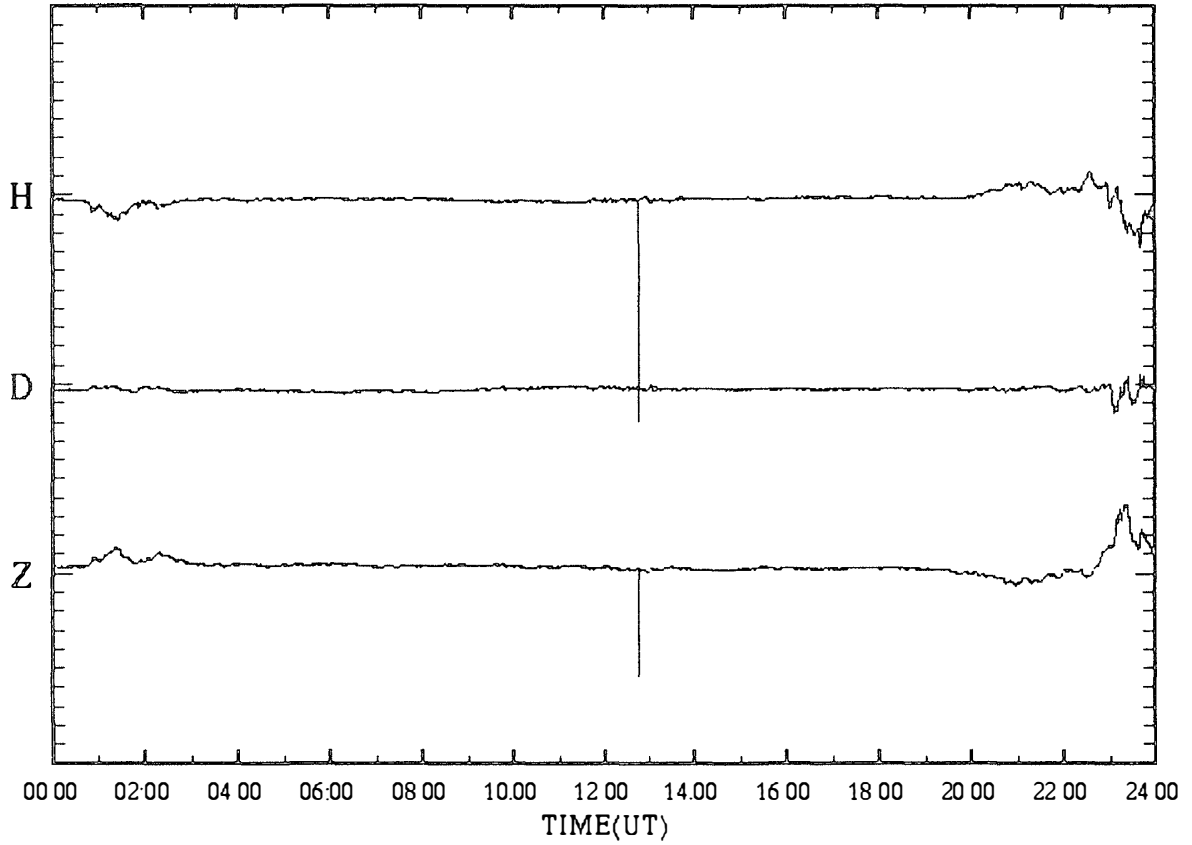

SYOWA magnetogram (100 nT/div)

13 Aug.1997 (DAY:225)

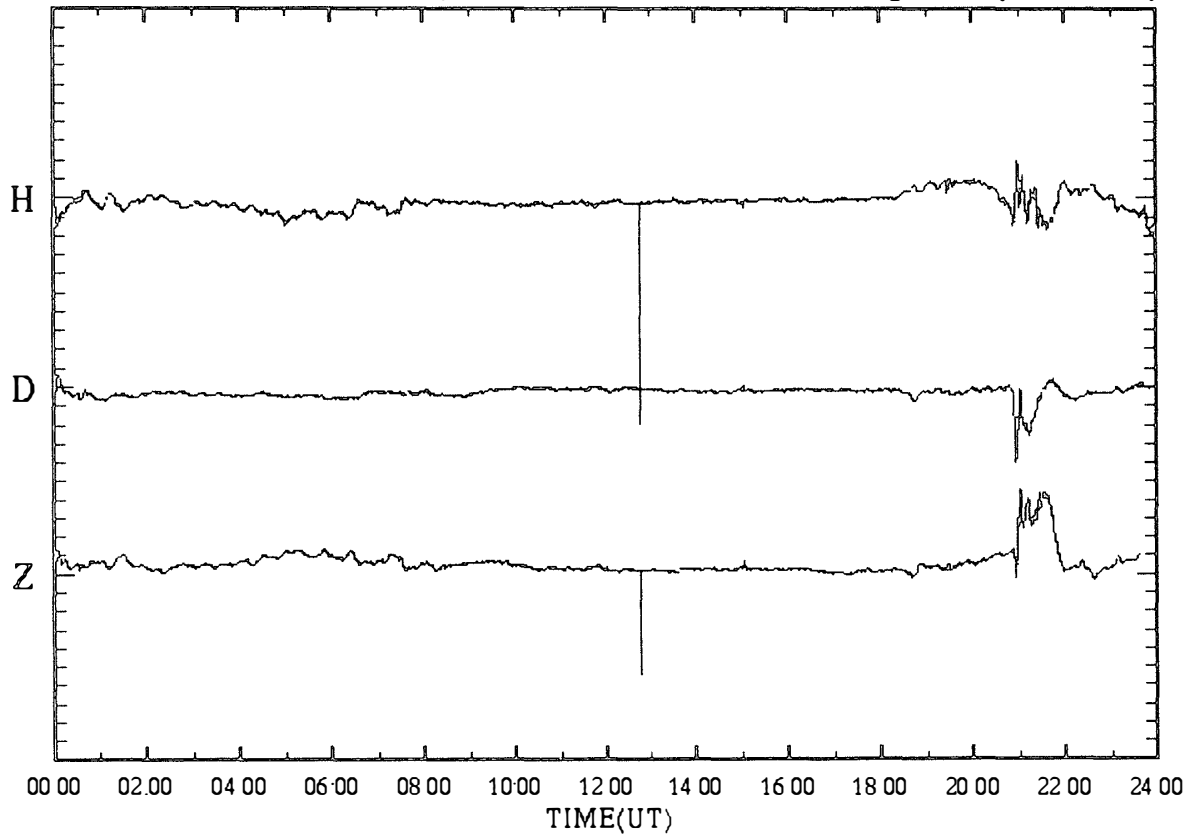

SYOWA magnetogram (100 nT/div)

14 Aug.1997 (DAY:226)

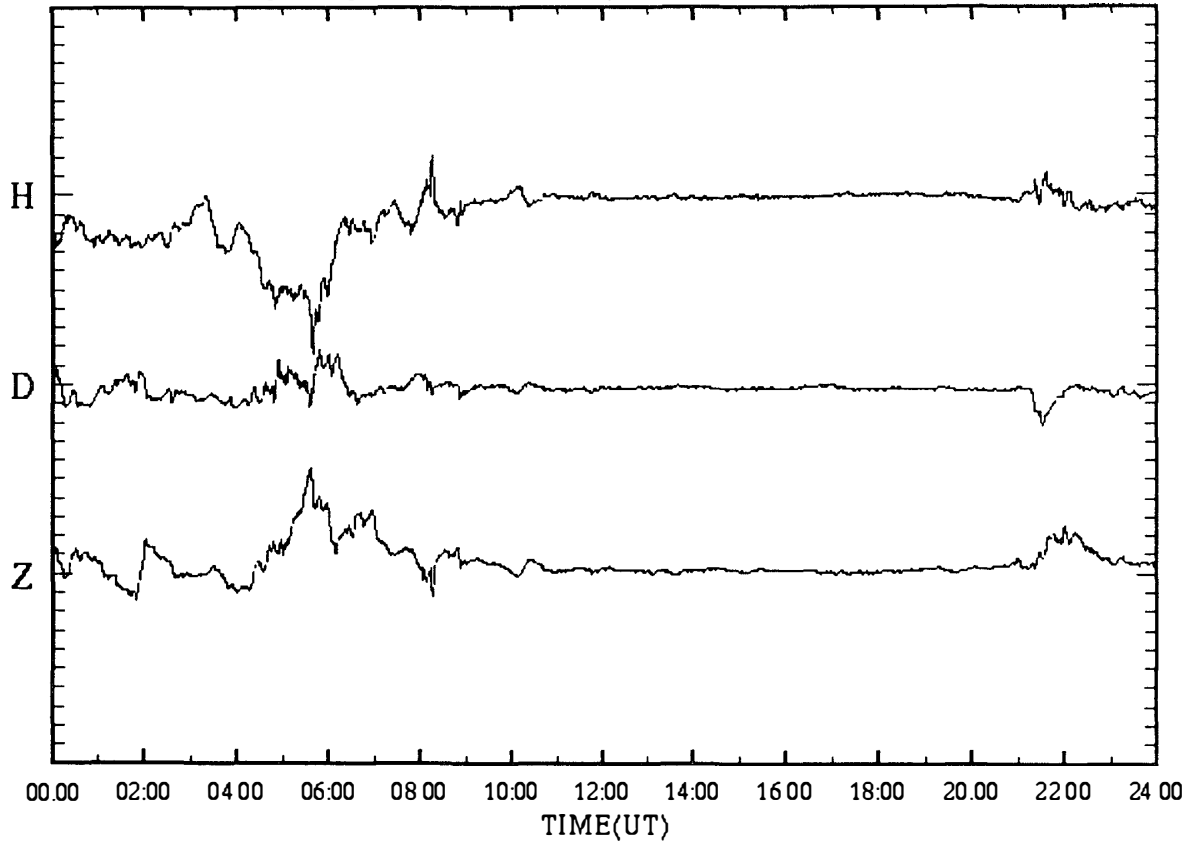

SYOWA magnetogram (100 nT/div)

15 Aug.1997 (DAY:227)

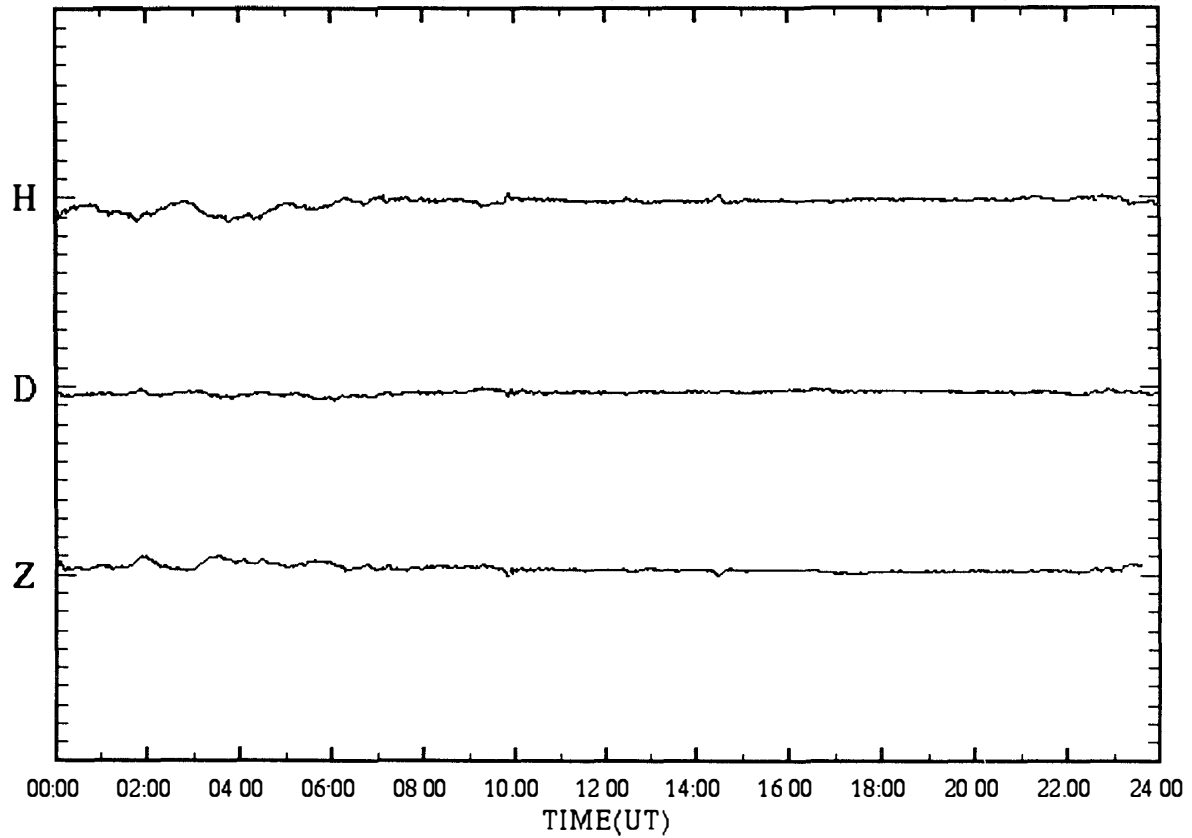

SYOWA magnetogram (100 nT/div)

16 Aug.1997 (DAY:228)

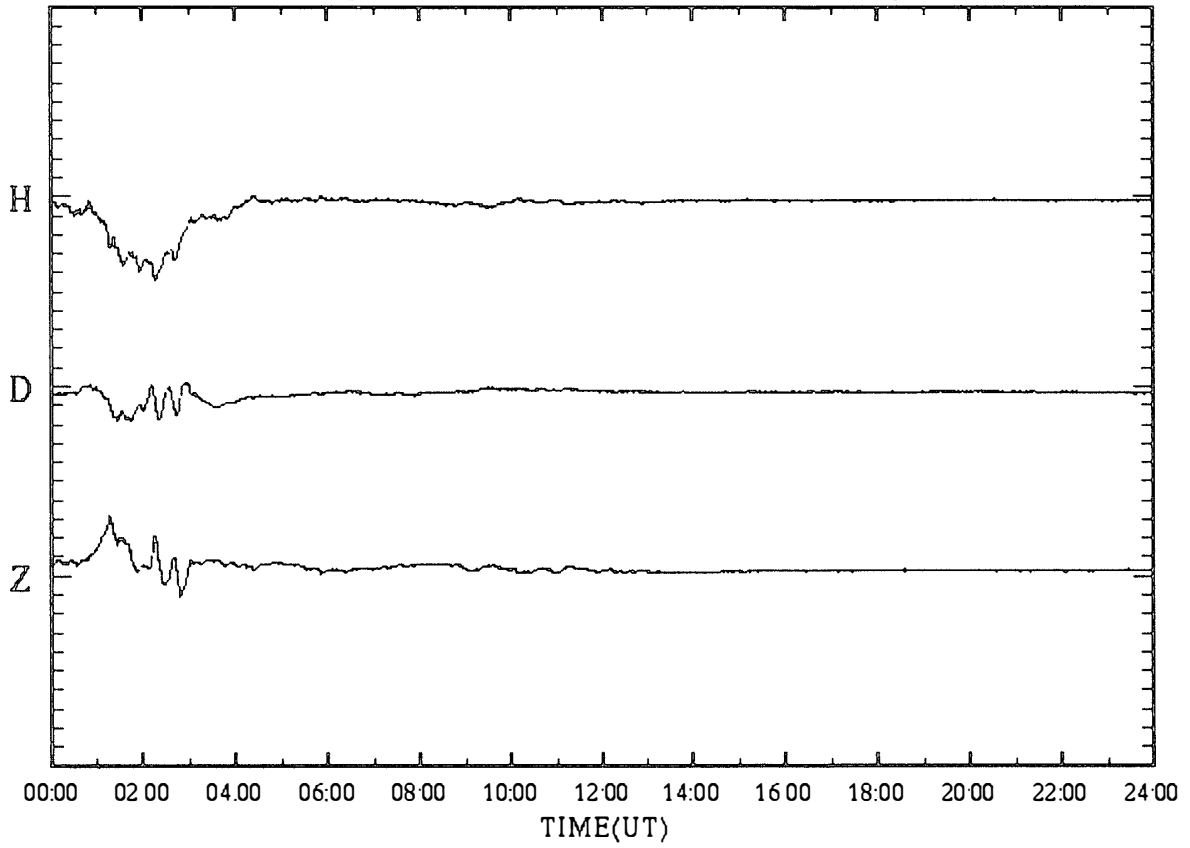

SYOWA magnetogram (100 nT/div)

17 Aug.1997 (DAY:229)

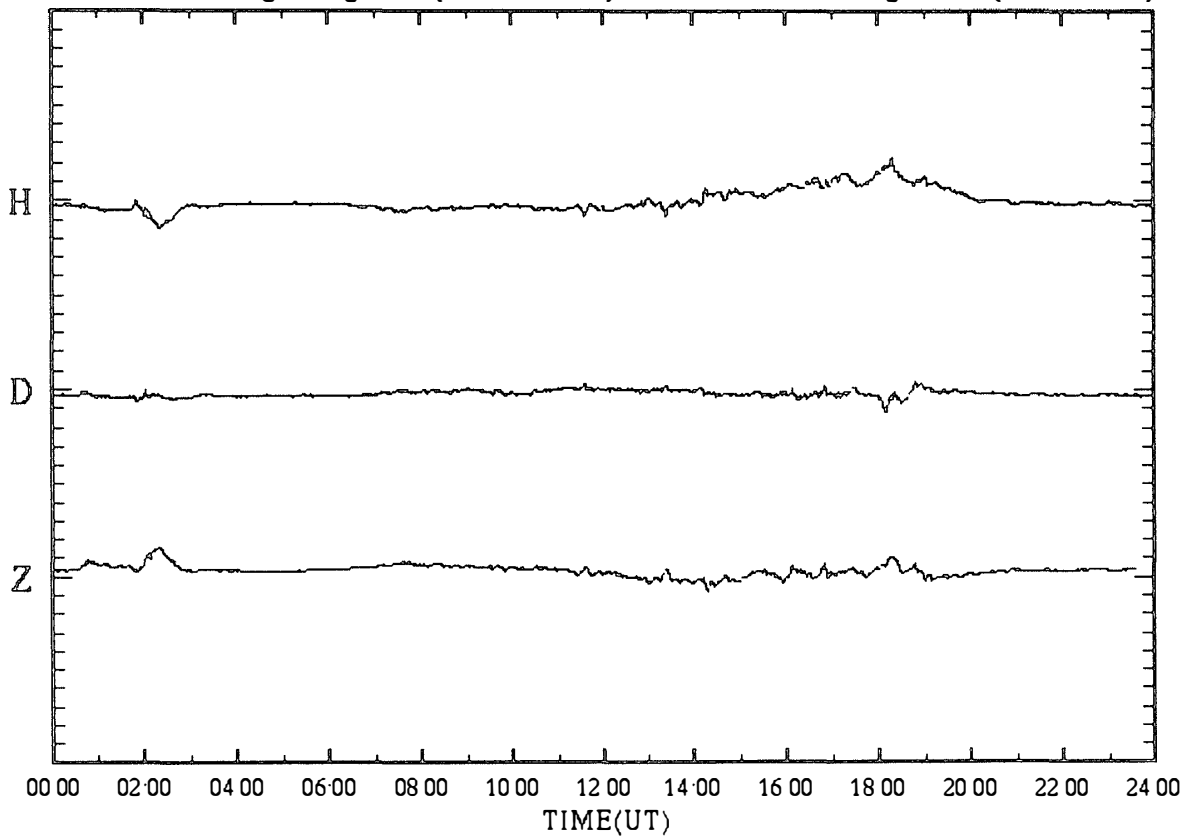



SYOWA magnetogram (100 nT/div)

18 Aug.1997 (DAY:230)

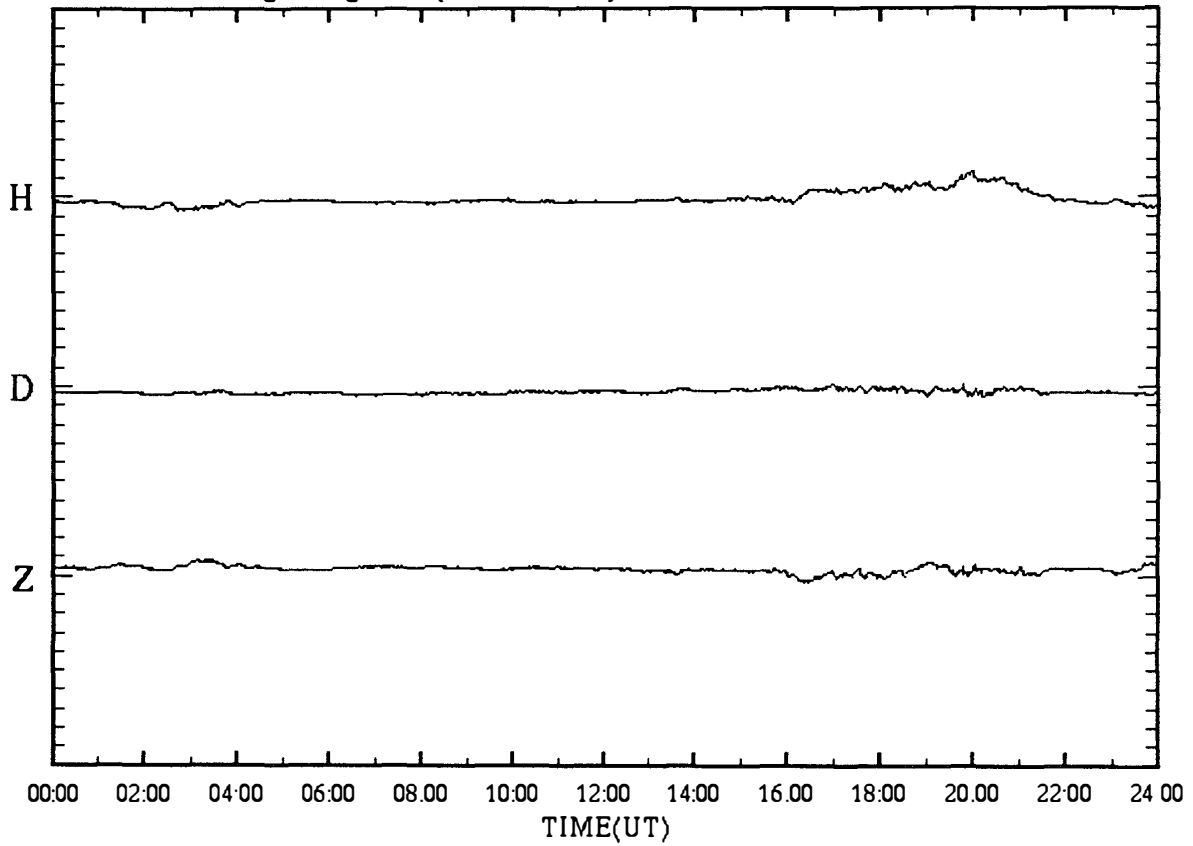

SYOWA magnetogram (100 nT/div)

19 Aug.1997 (DAY:231)

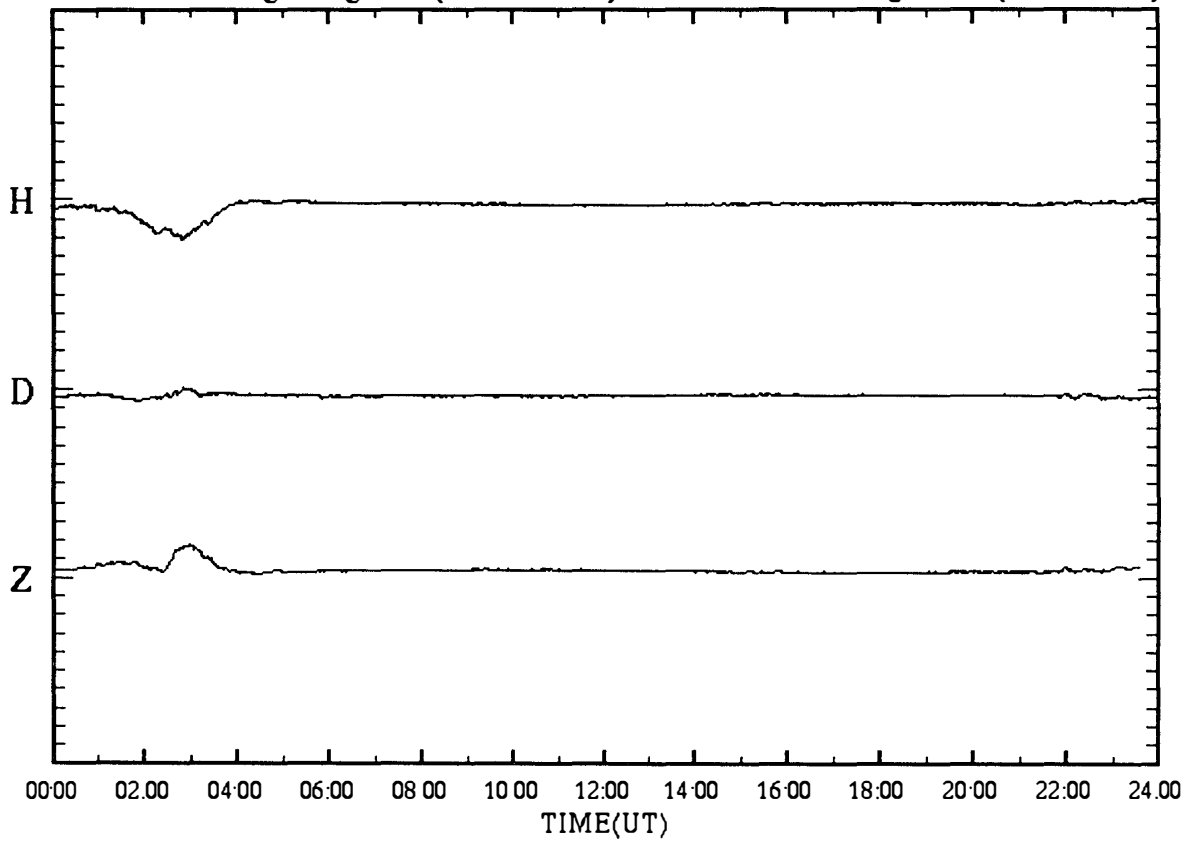

SYOWA magnetogram (100 nT/div)

20 Aug.1997 (DAY:232)

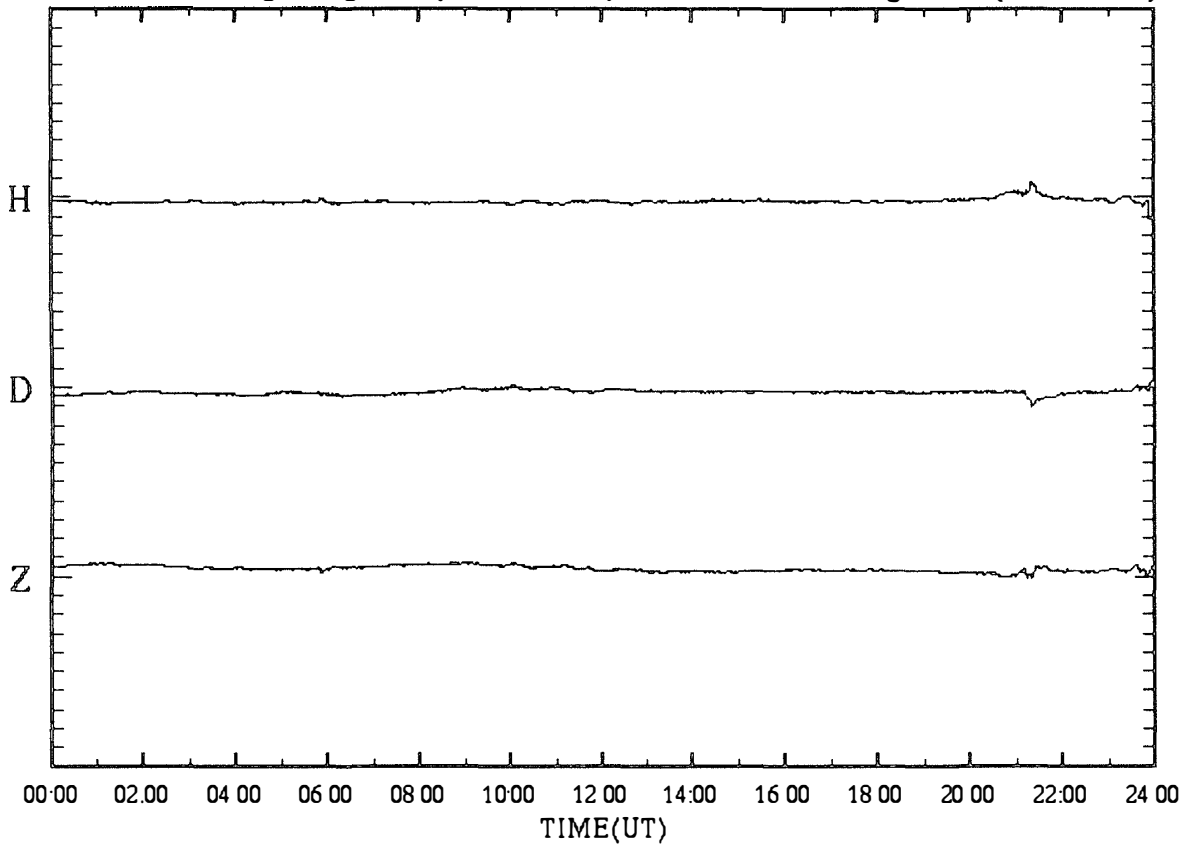

SYOWA magnetogram (100 nT/div)

21 Aug.1997 (DAY:233)

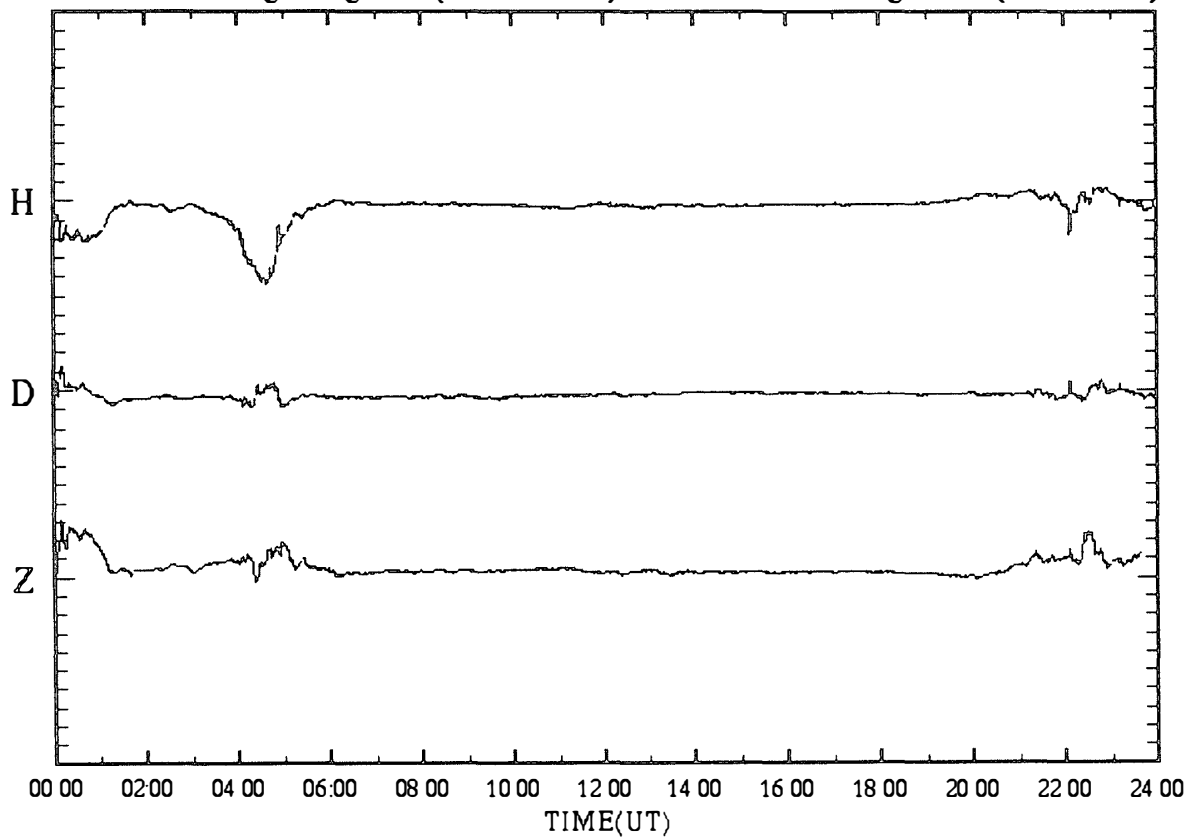

SYOWA magnetogram (100 nT/div)

22 Aug.1997 (DAY:234)

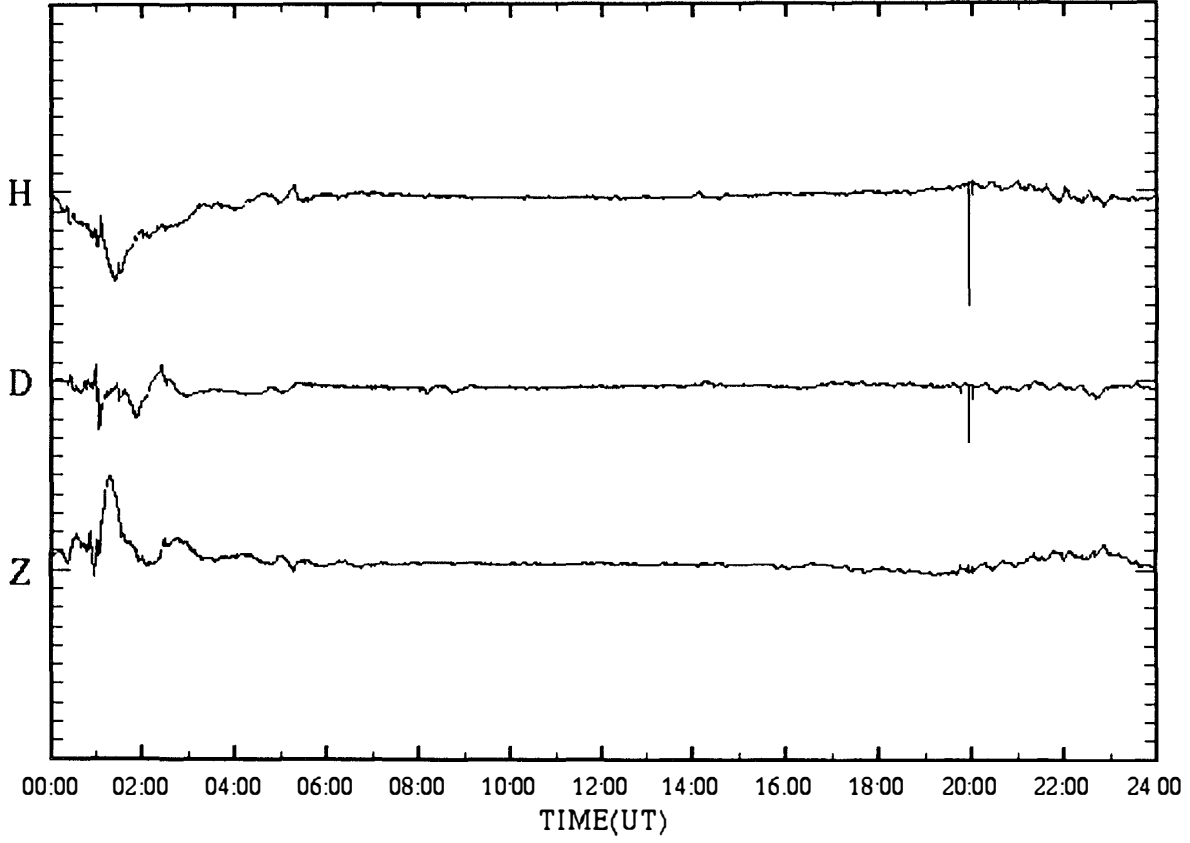

SYOWA magnetogram (100 nT/div)

23 Aug.1997 (DAY:235)

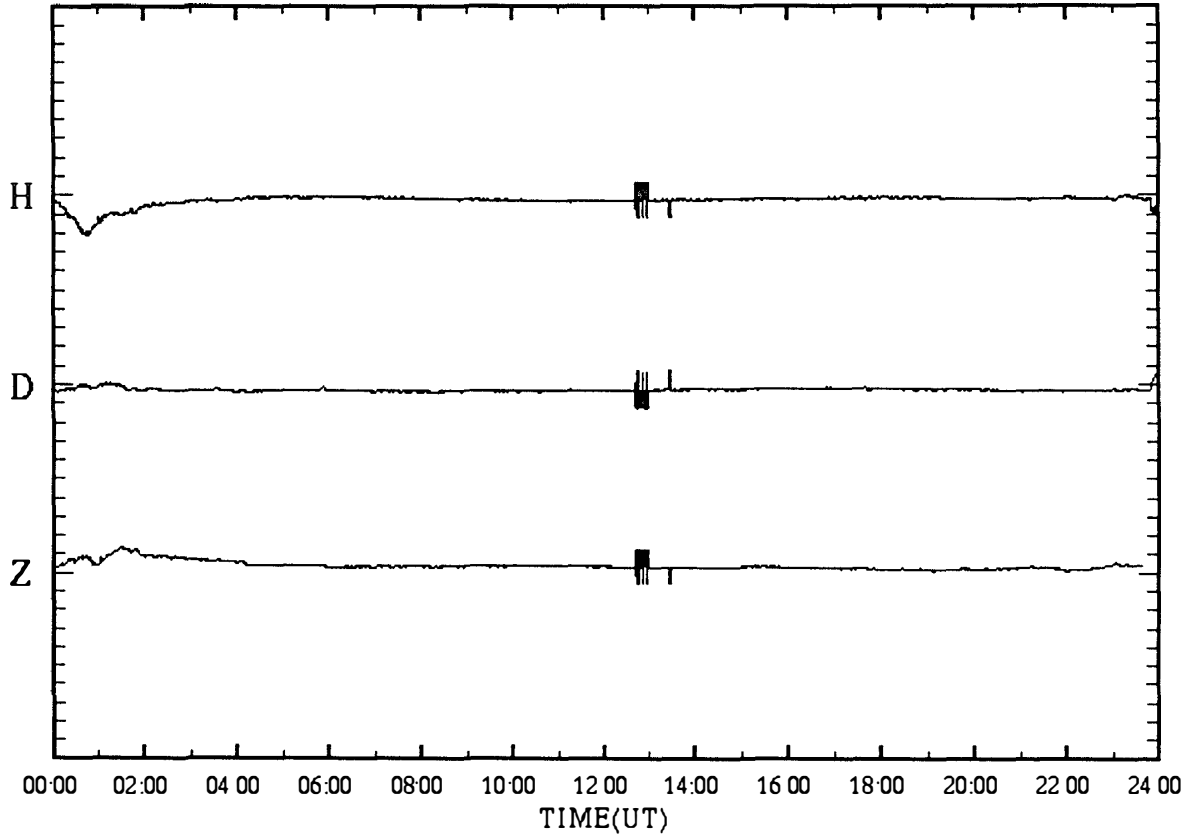

SYOWA magnetogram (100 nT/div)

24 Aug.1997 (DAY:236)

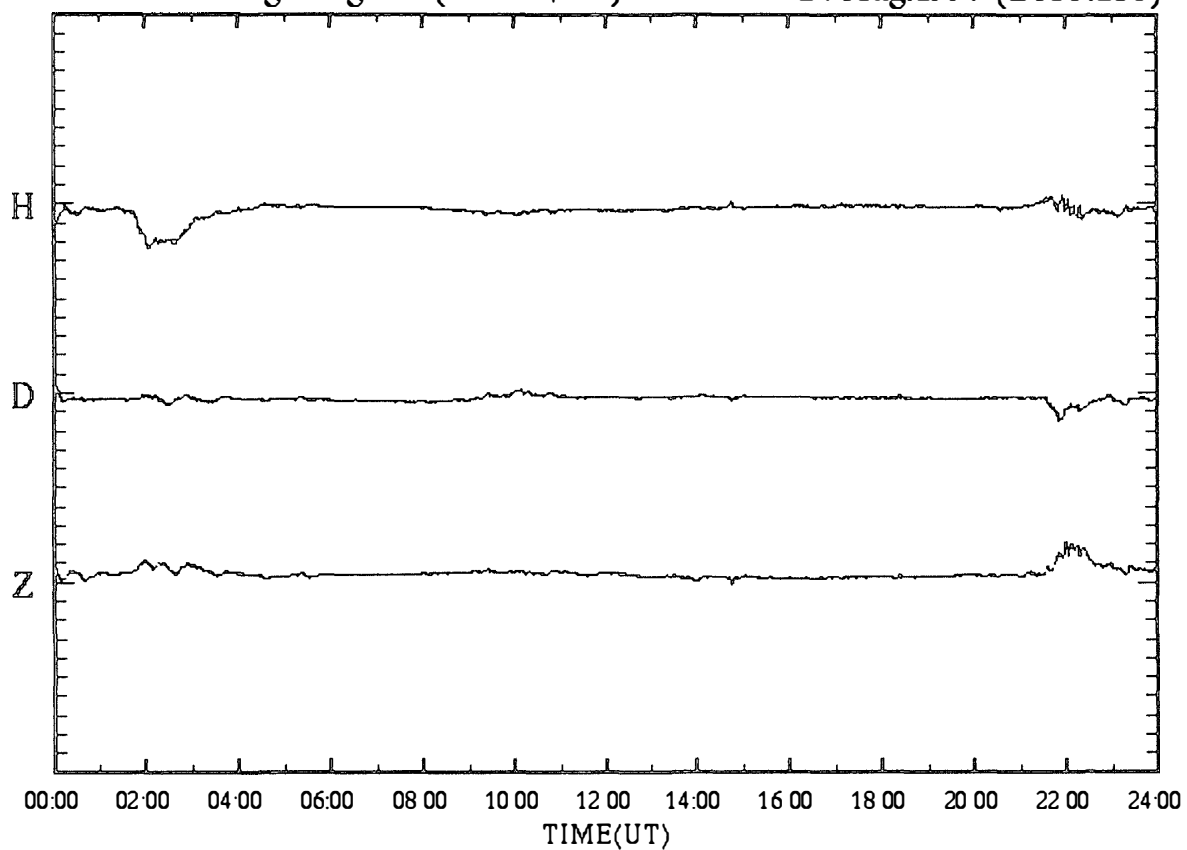

SYOWA magnetogram (100 nT/div)

25 Aug.1997 (DAY:237)

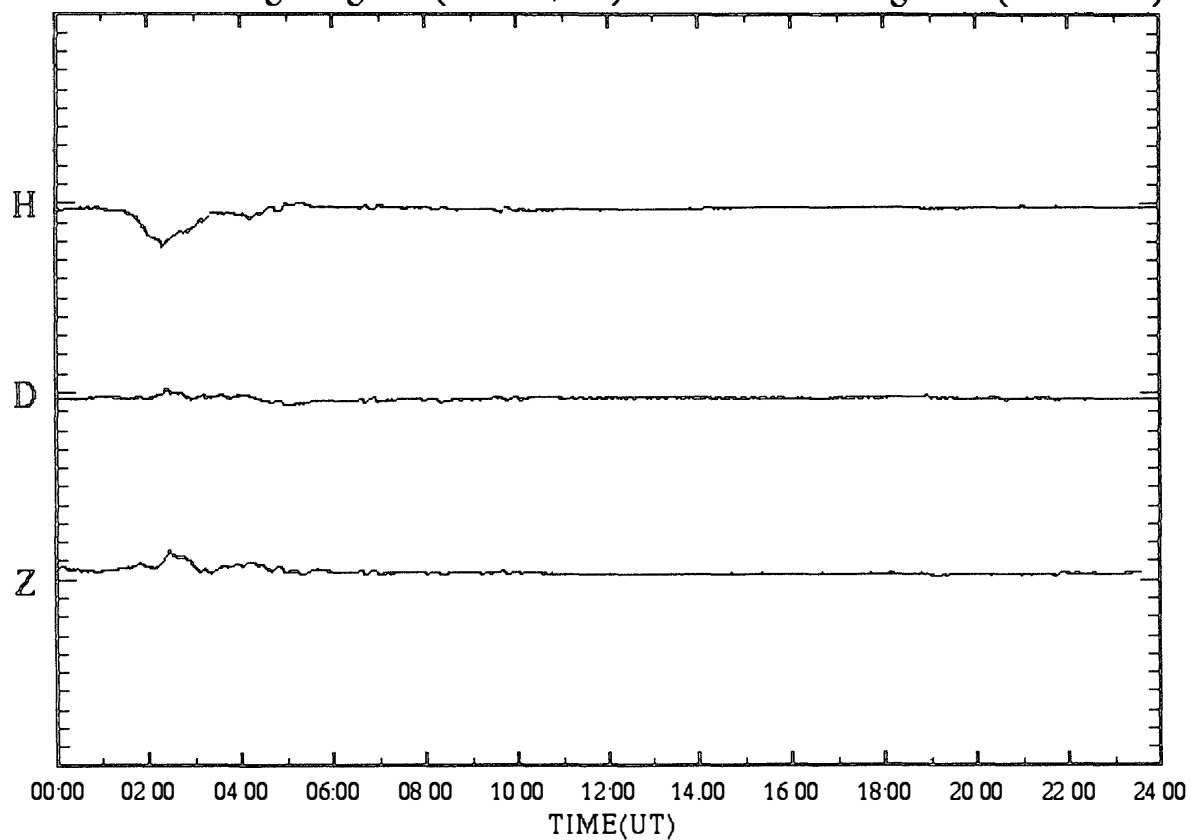

SYOWA magnetogram (100 nT/div)

26 Aug.1997 (DAY:238)

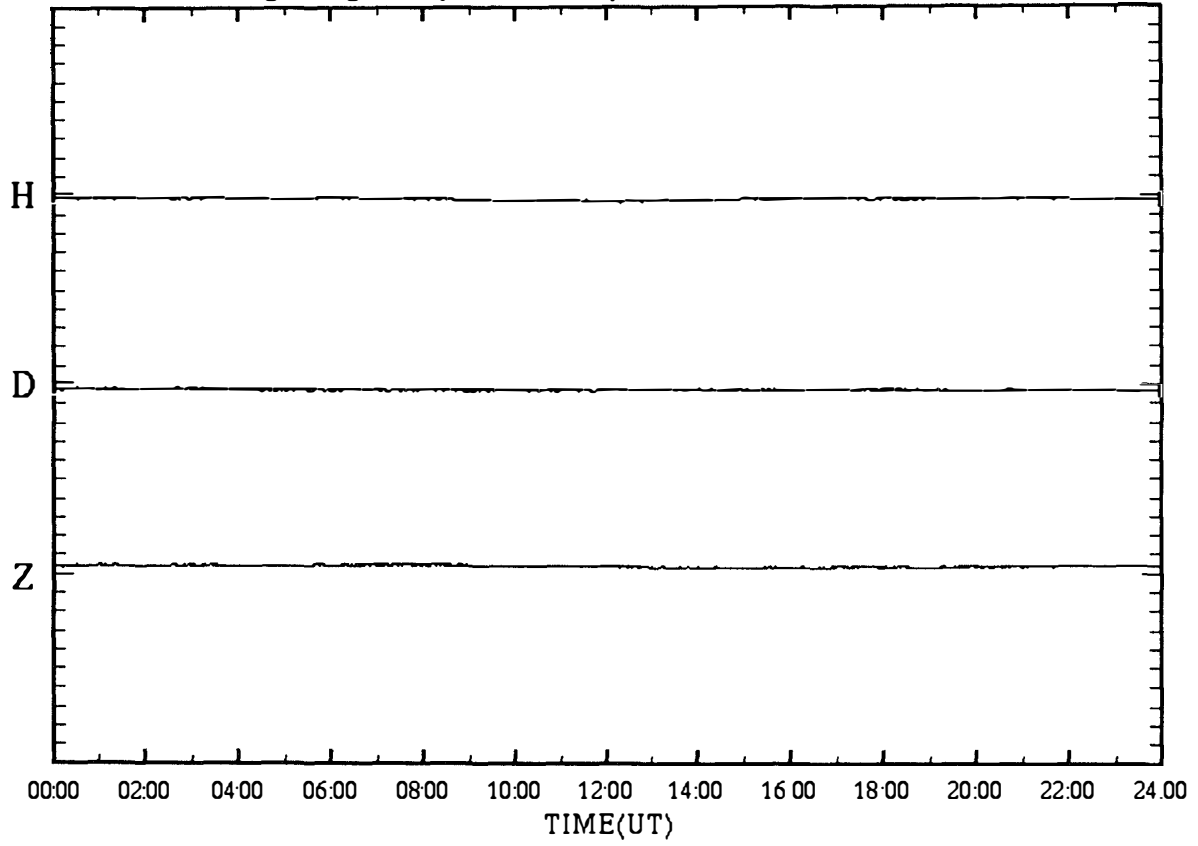

SYOWA magnetogram (100 nT/div)

27 Aug.1997 (DAY:239)

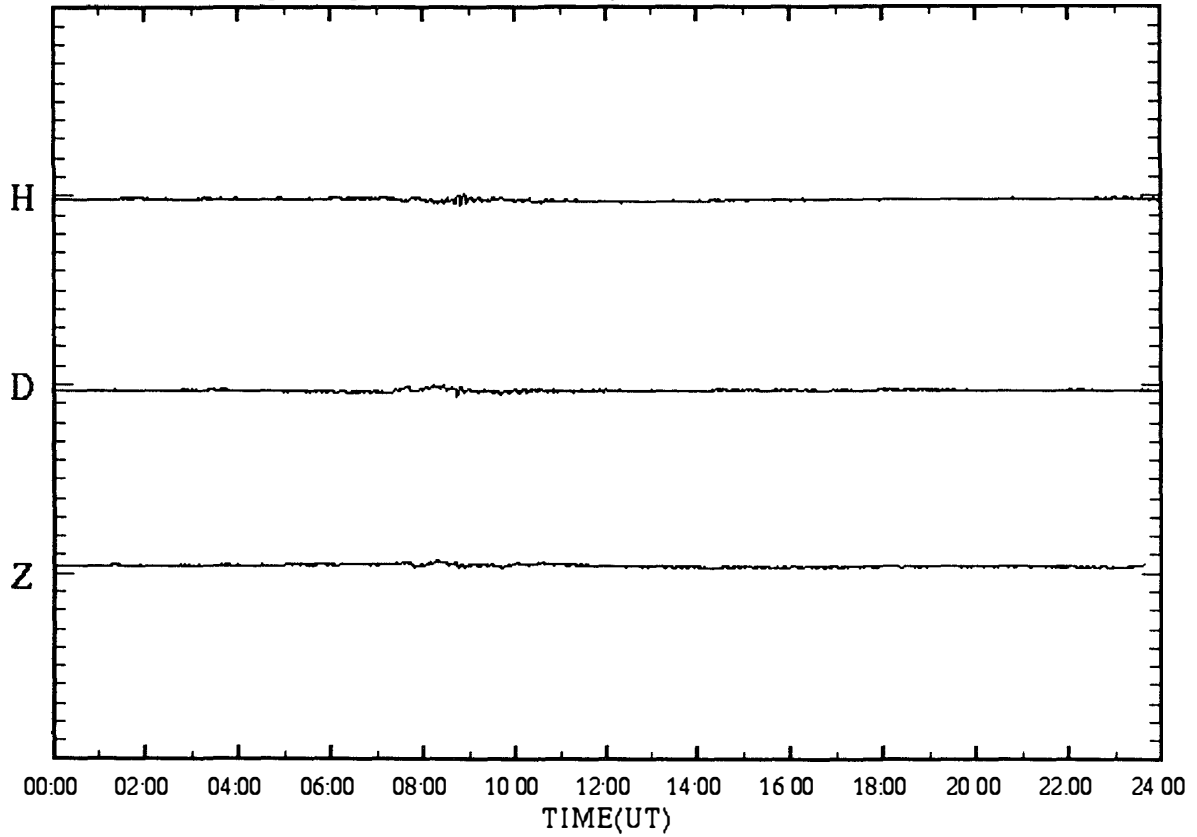

SYOWA magnetogram (100 nT/div)

28 Aug.1997 (DAY:240)

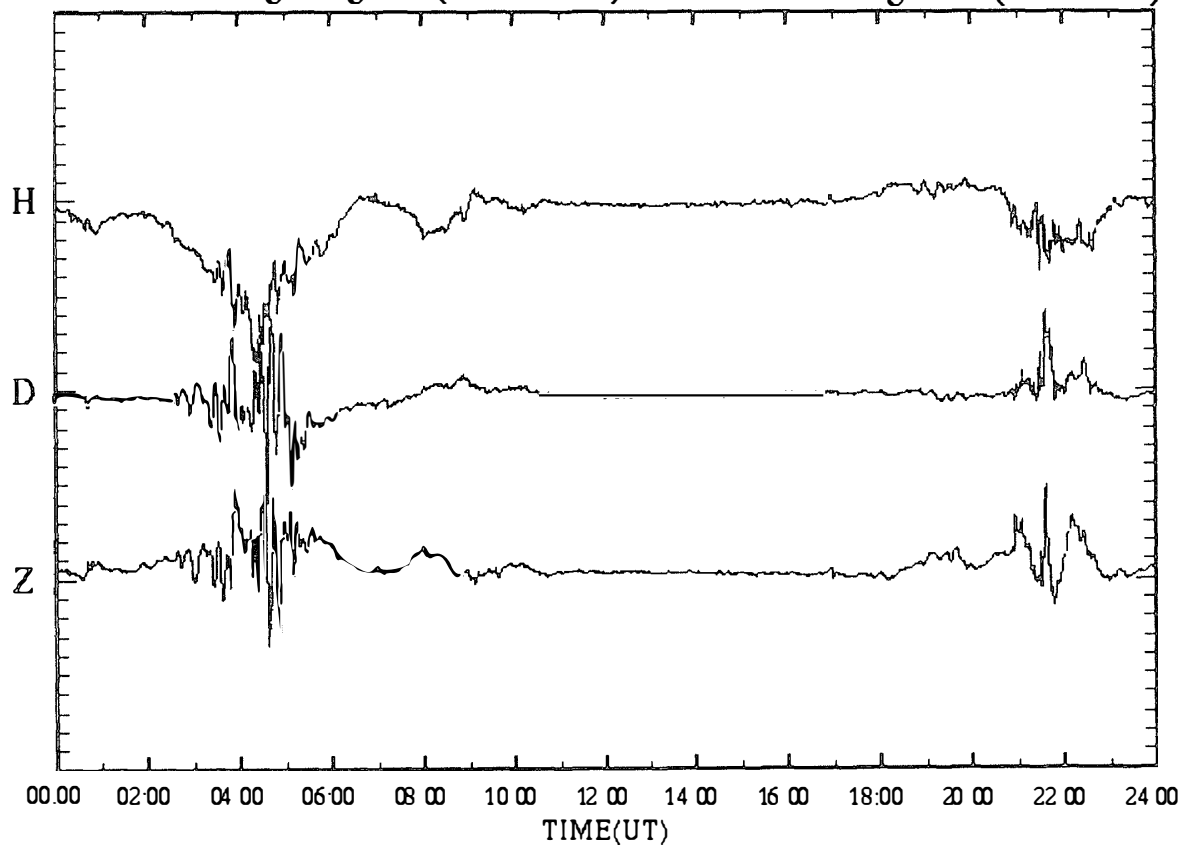

SYOWA magnetogram (100 nT/div)

29 Aug.1997 (DAY:241)

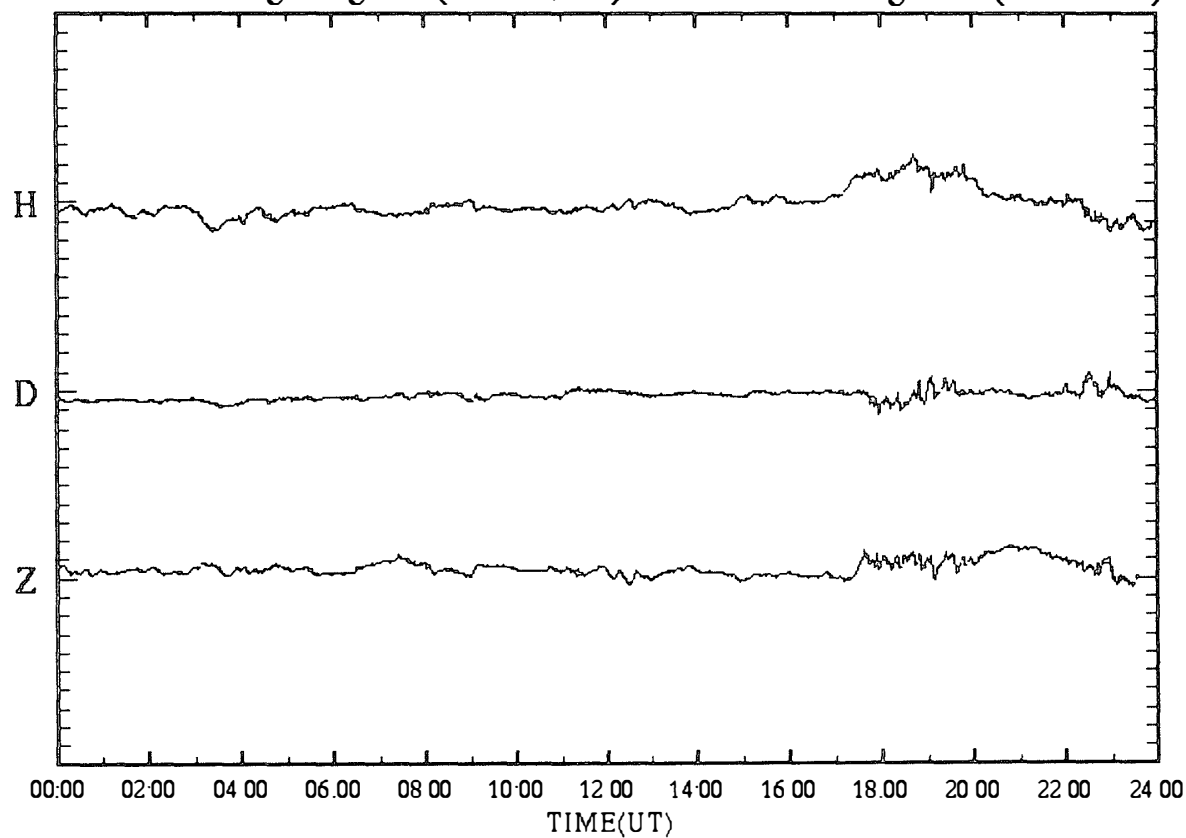

SYOWA magnetogram (100 nT/div)

30 Aug.1997 (DAY:242)

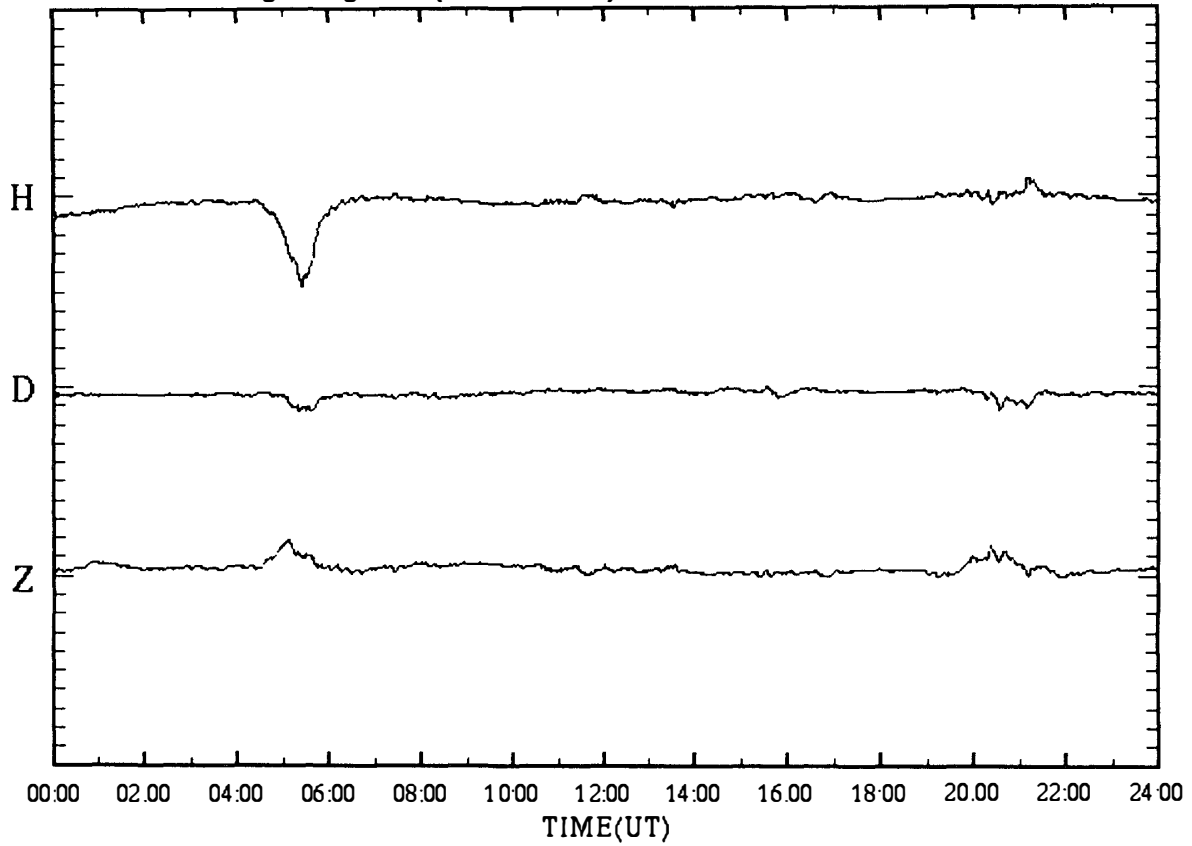

SYOWA magnetogram (100 nT/div)

31 Aug.1997 (DAY:243)

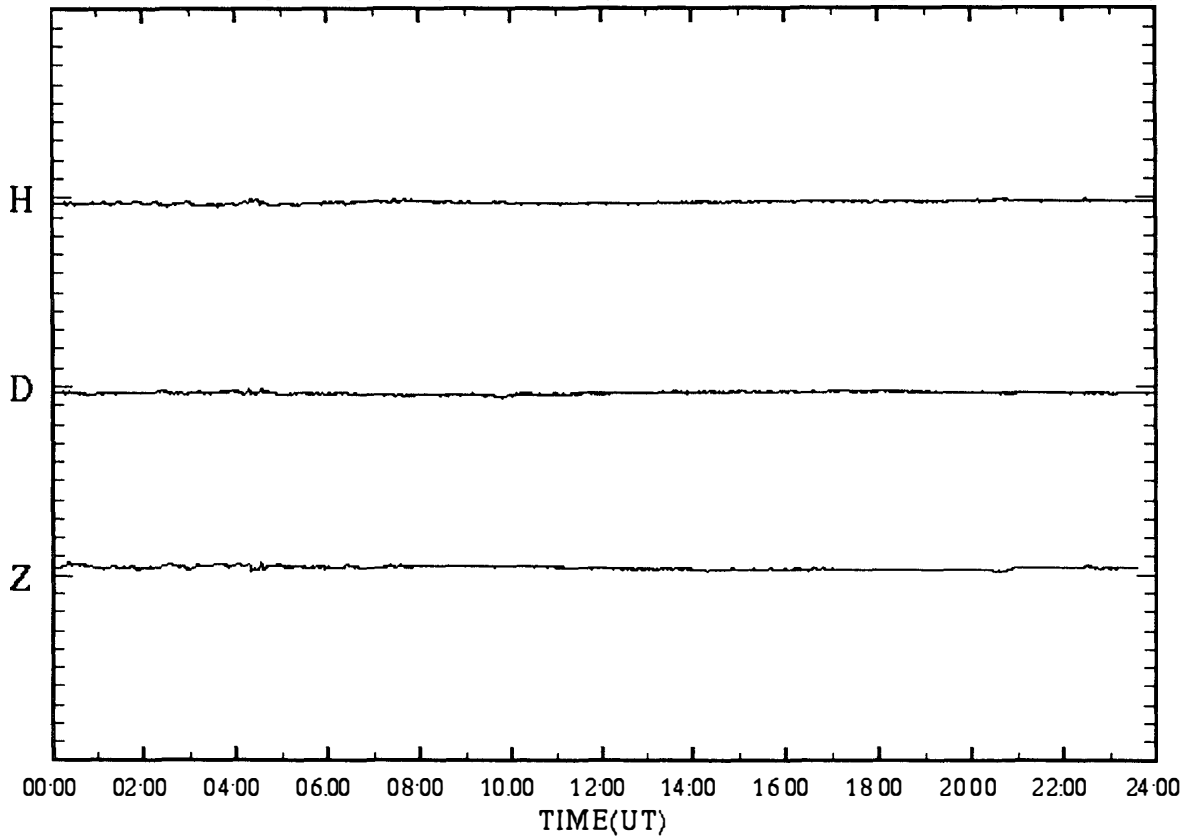

SYOWA magnetogram (100 nT/div)

01 Sep.1997 (DAY:244)

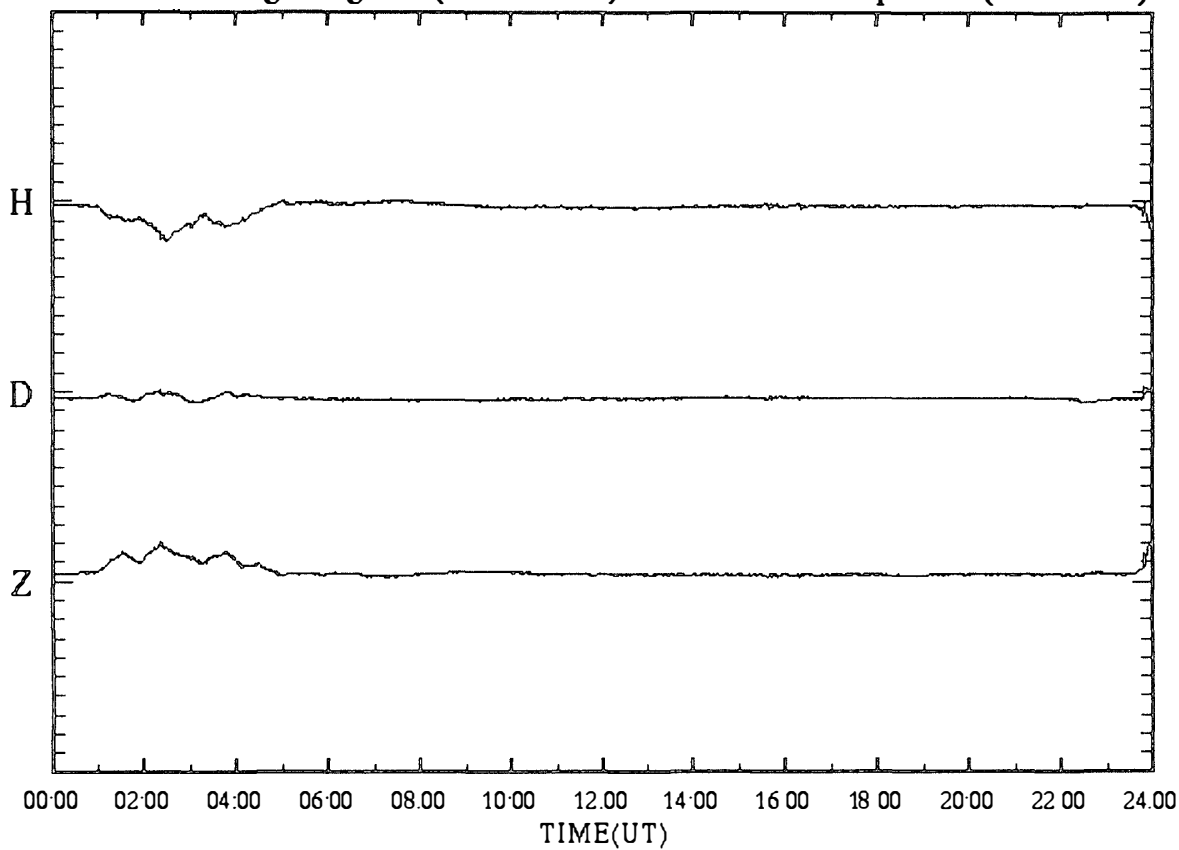

SYOWA magnetogram (100 nT/div)

02 Sep.1997 (DAY:245)

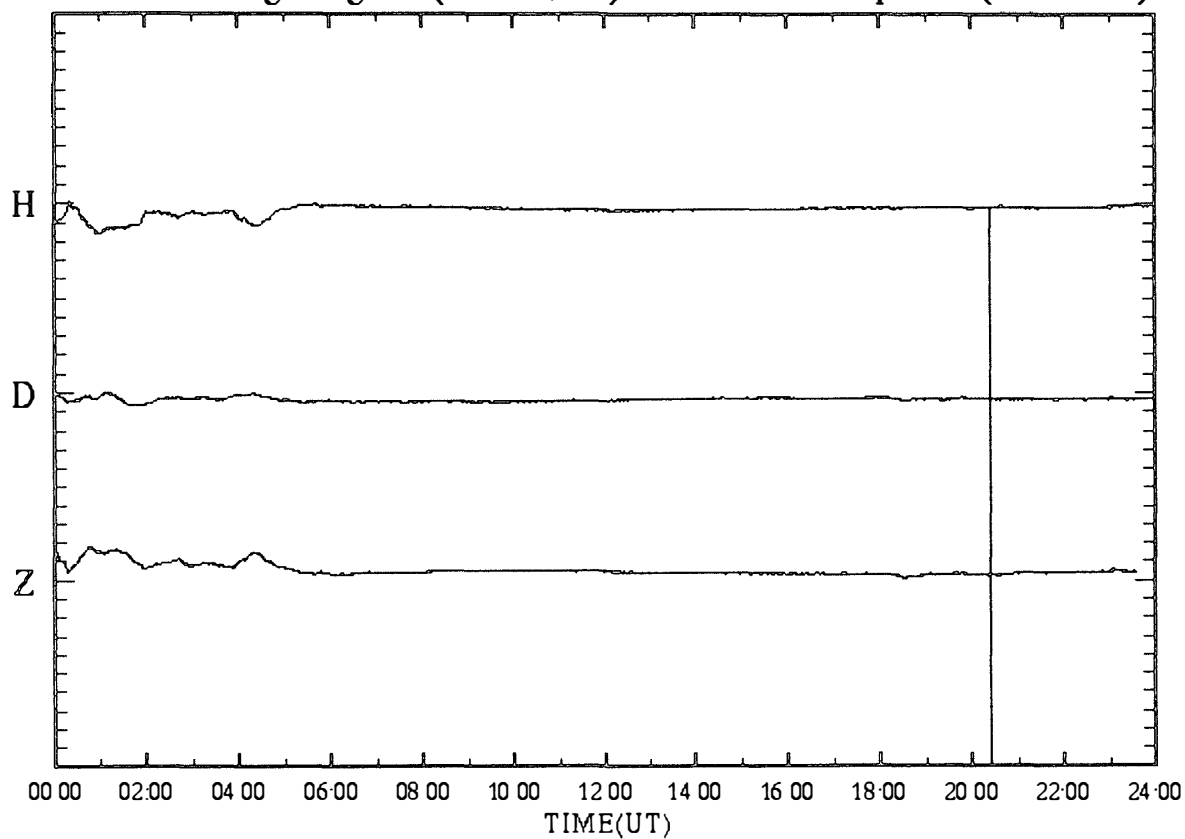



SYOWA magnetogram (100 nT/div)

03 Sep.1997 (DAY:246)

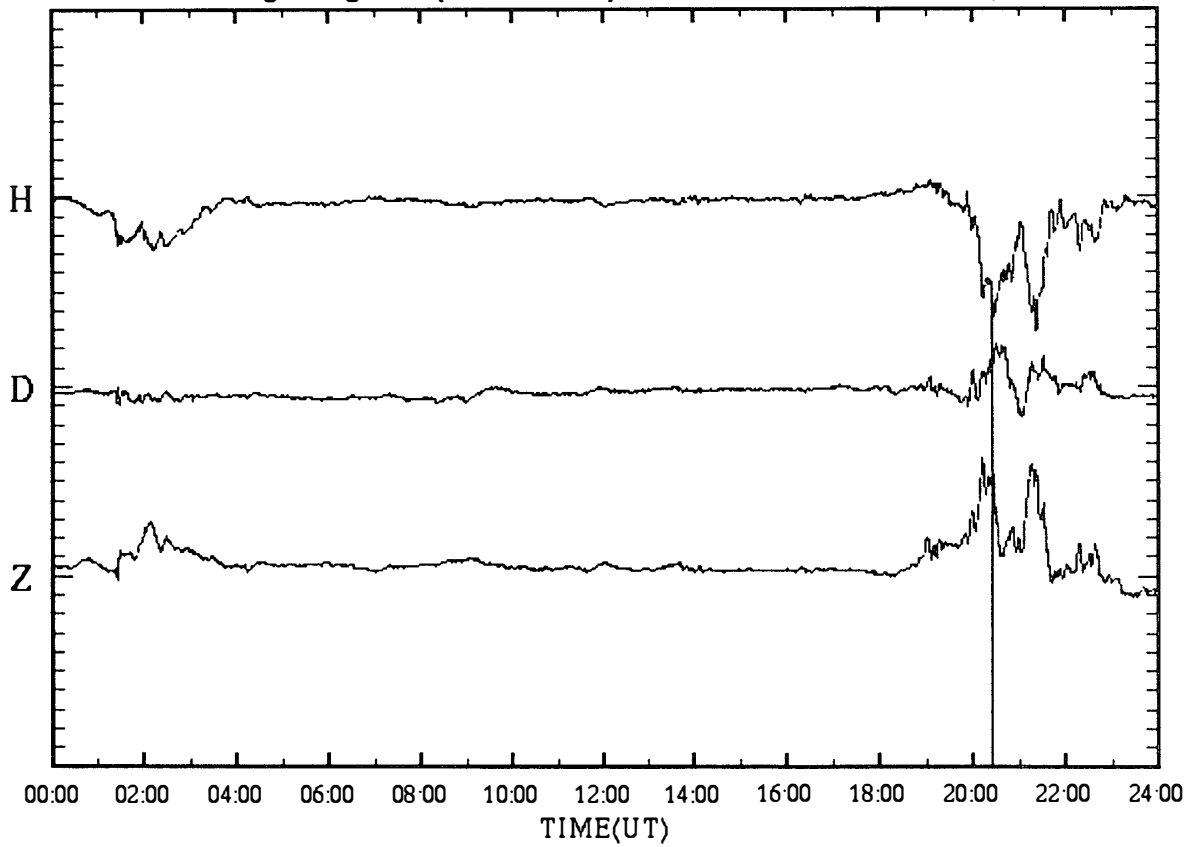

SYOWA magnetogram (100 nT/div)

04 Sep.1997 (DAY:247)

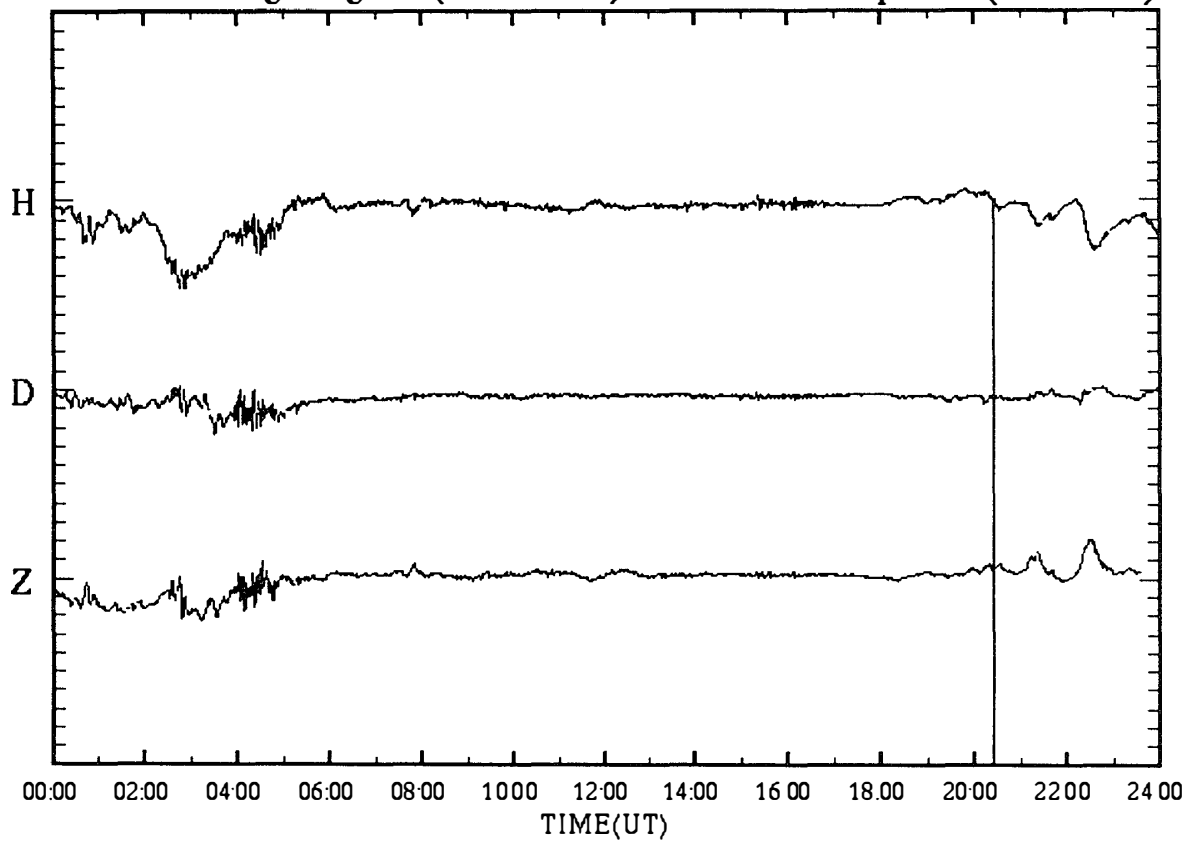

SYOWA magnetogram (100 nT/div)

05 Sep.1997 (DAY:248)

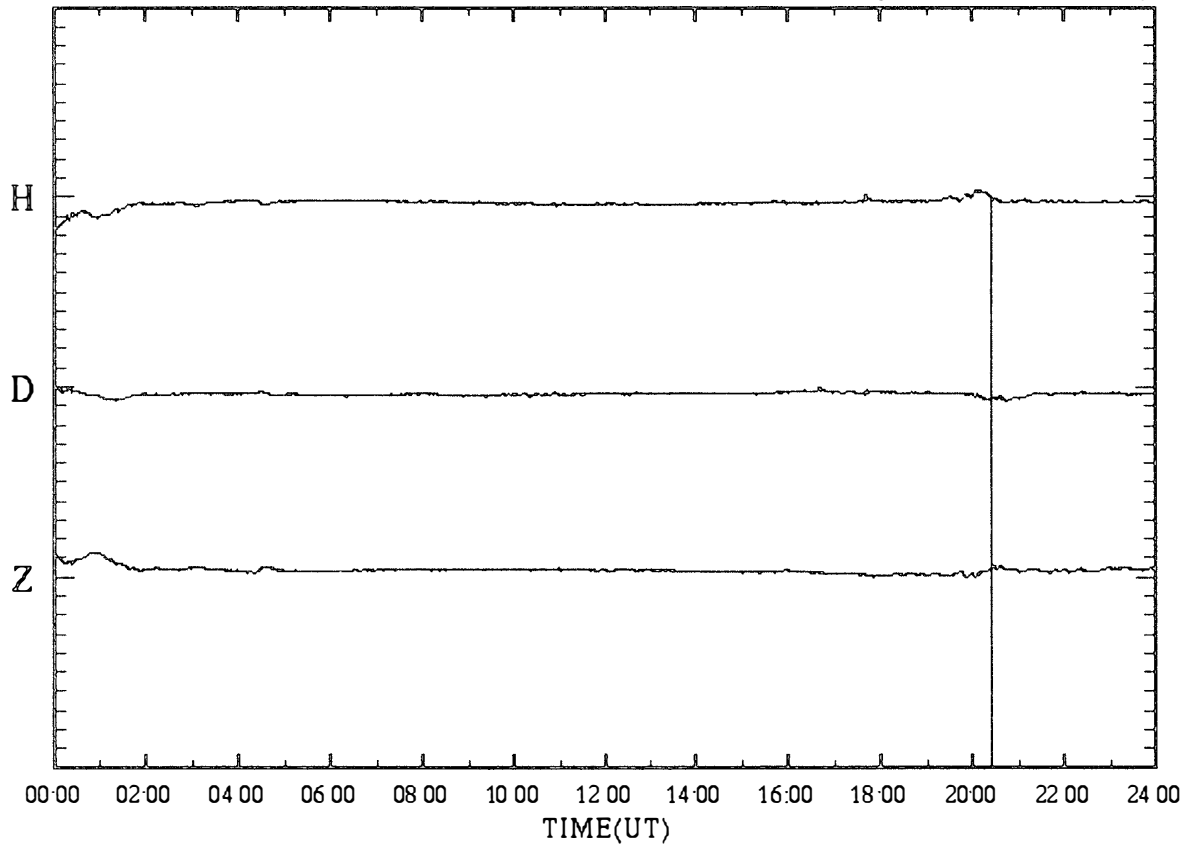

SYOWA magnetogram (100 nT/div)

06 Sep.1997 (DAY:249)

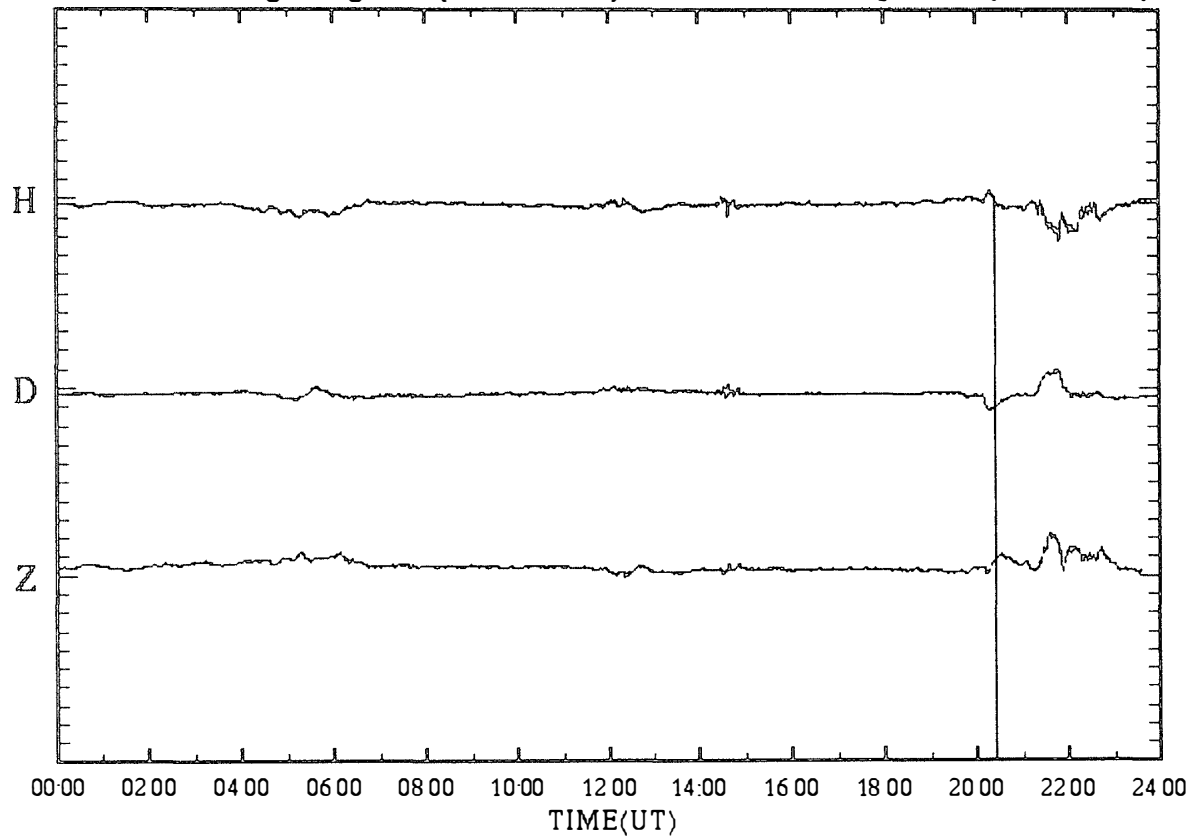

SYOWA magnetogram (100 nT/div)

07 Sep.1997 (DAY:250)

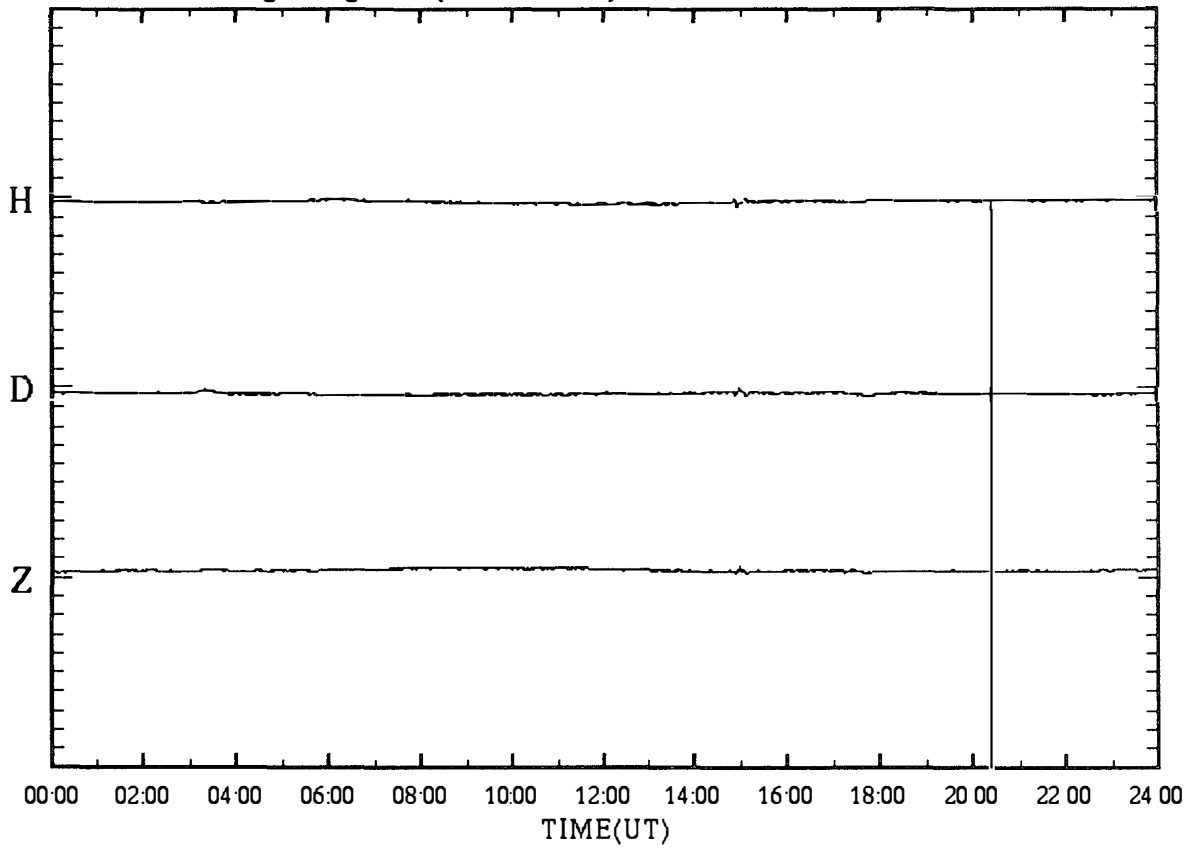

SYOWA magnetogram (100 nT/div)

08 Sep.1997 (DAY:251)

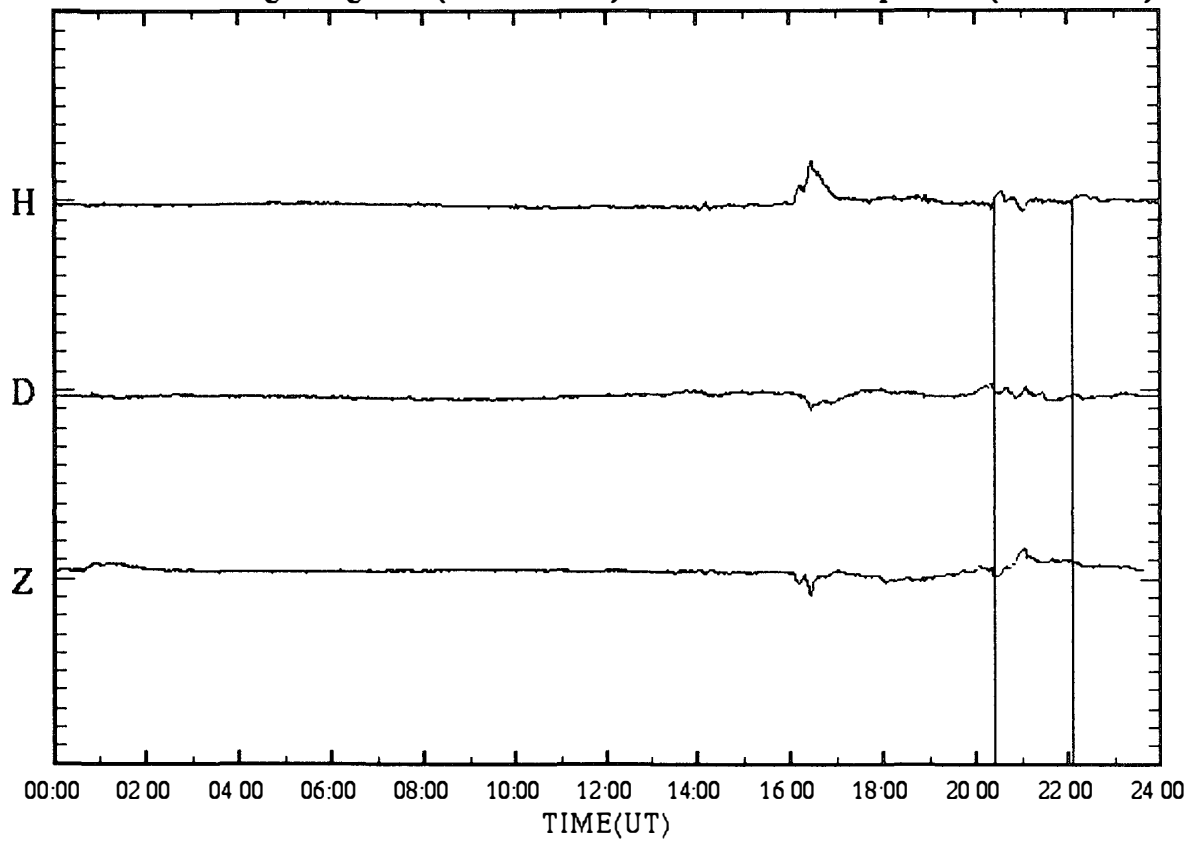

SYOWA magnetogram (100 nT/div)

09 Sep.1997 (DAY:252)

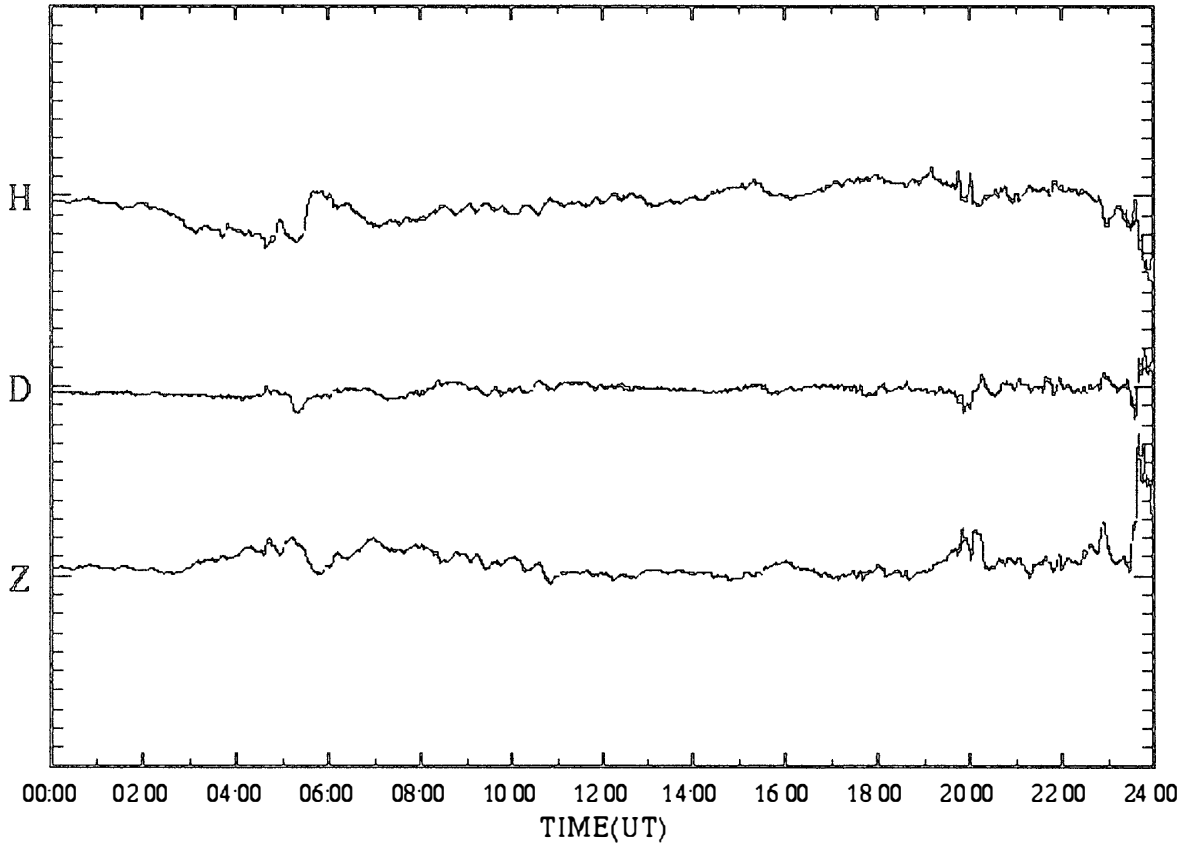

SYOWA magnetogram (100 nT/div)

10 Sep.1997 (DAY:253)

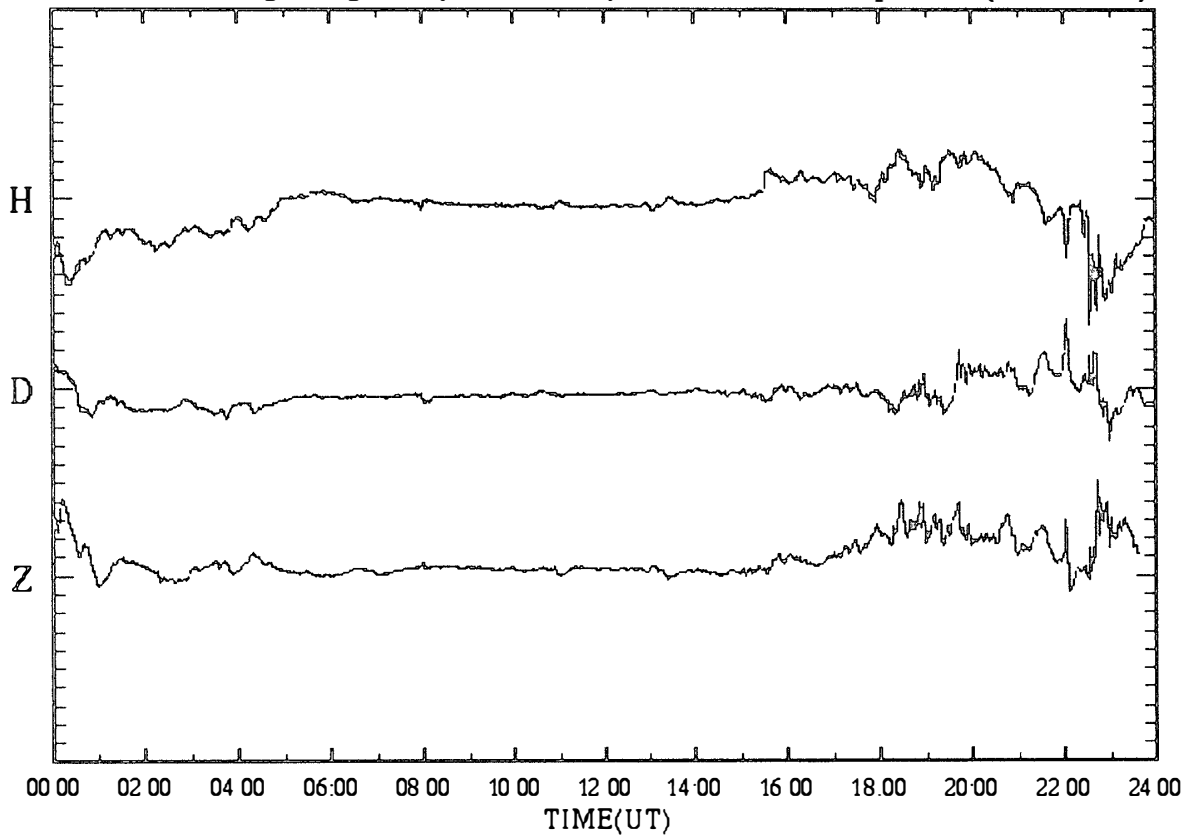

SYOWA magnetogram (100 nT/div)

11 Sep.1997 (DAY:254)

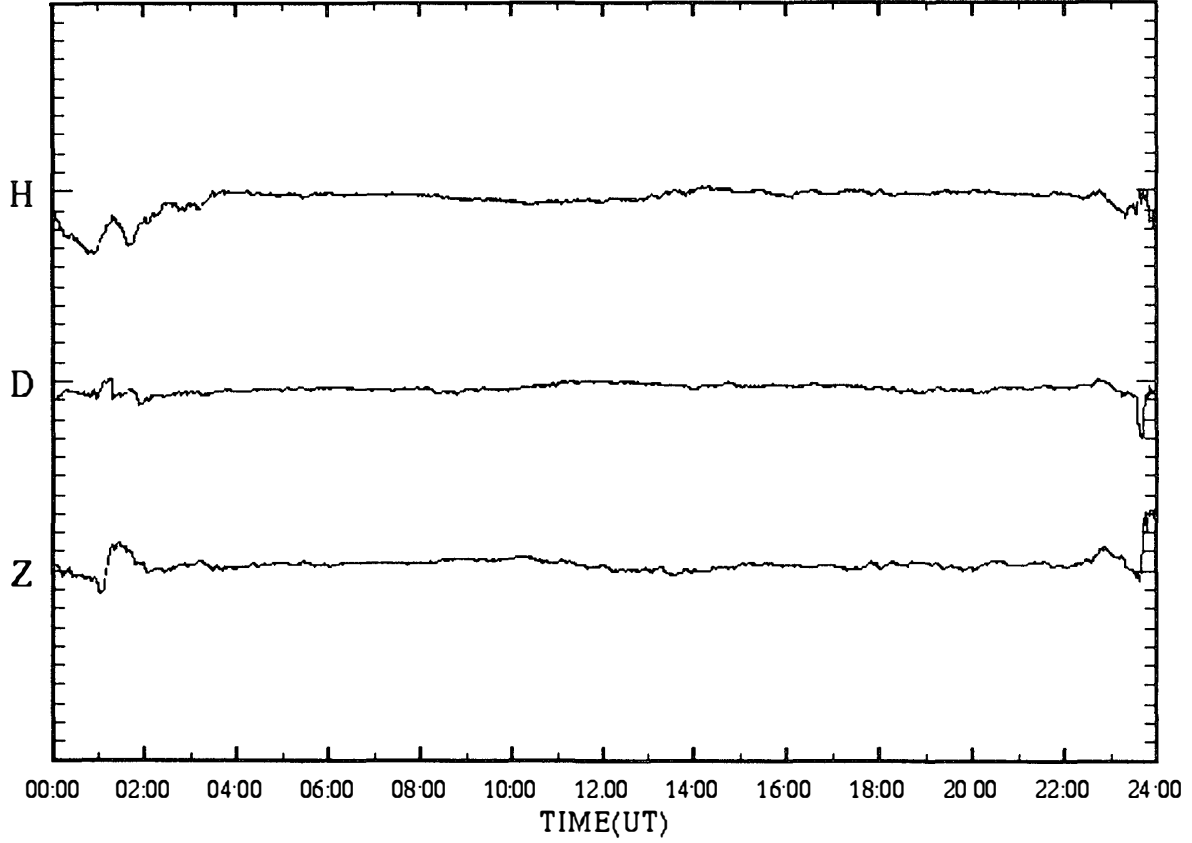

SYOWA magnetogram (100 nT/div)

12 Sep.1997 (DAY:255)

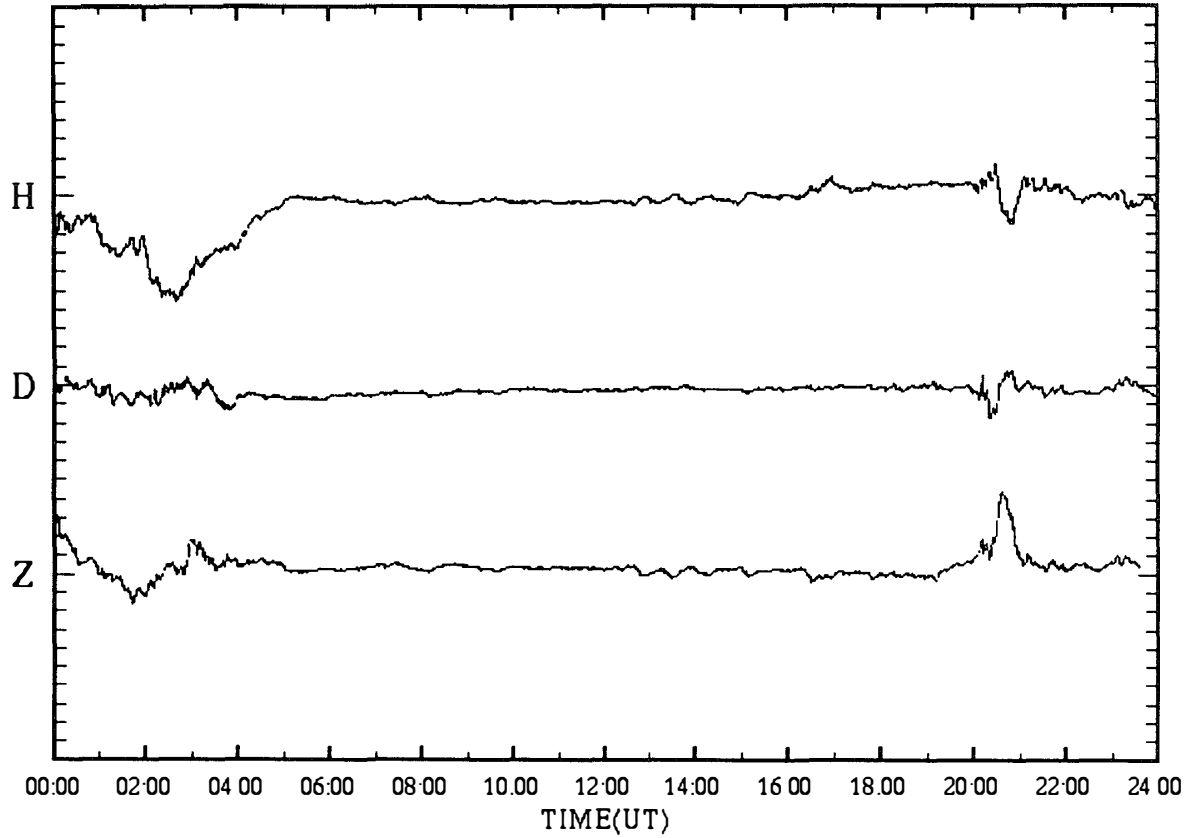

SYOWA magnetogram (100 nT/div)

13 Sep.1997 (DAY:256)

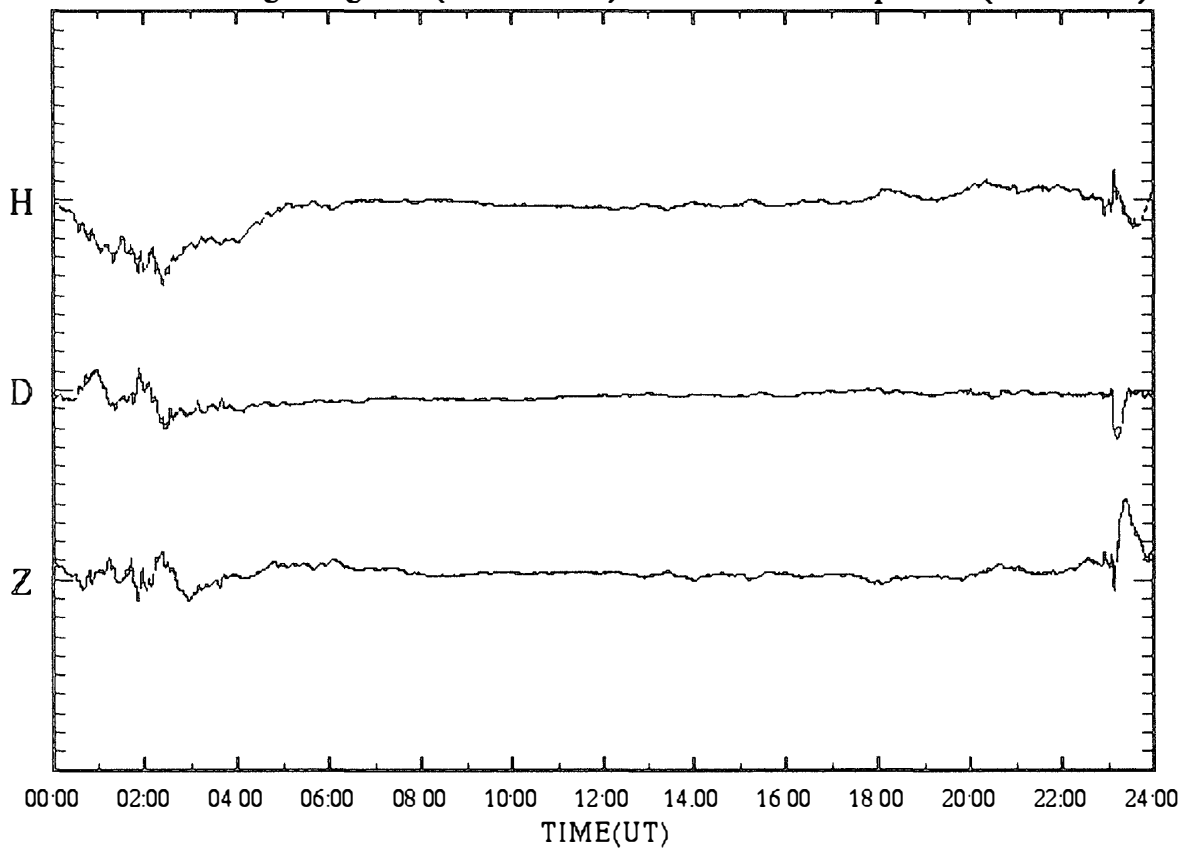

SYOWA magnetogram (100 nT/div)

14 Sep.1997 (DAY:257)

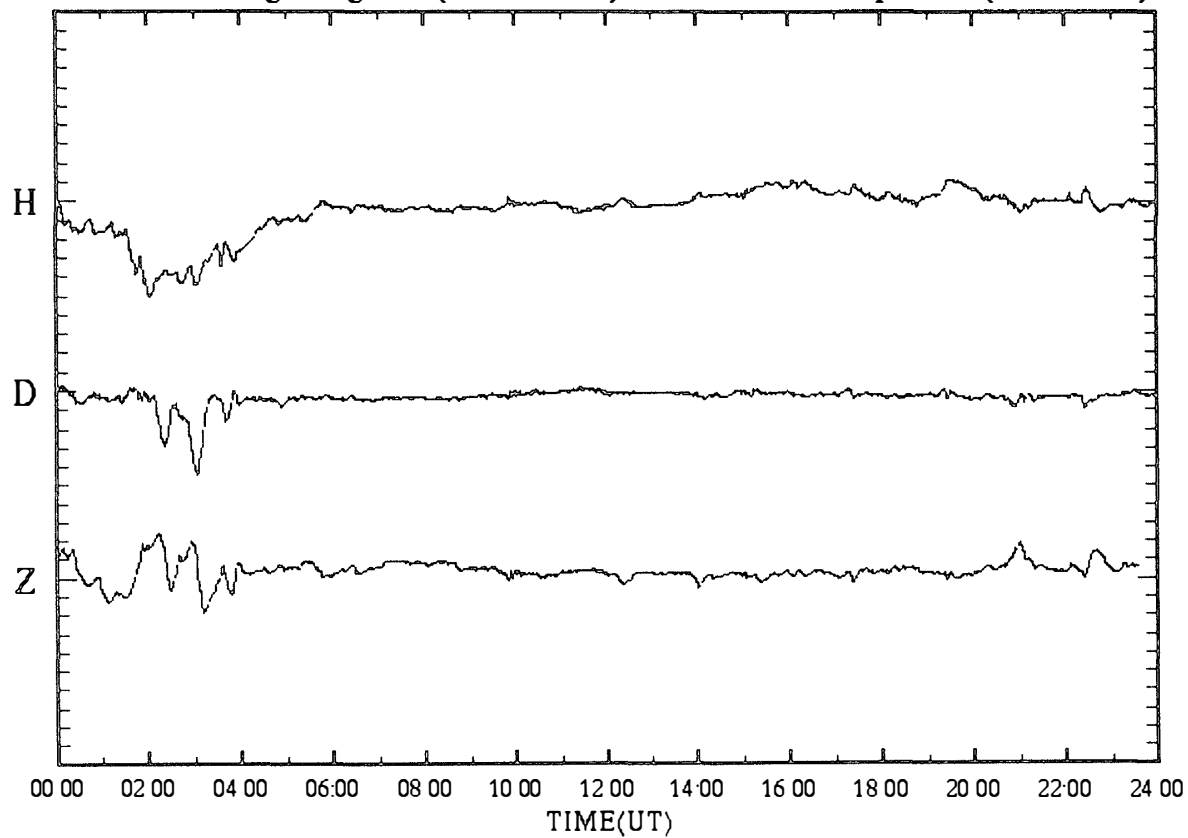

SYOWA magnetogram (100 nT/div)

15 Sep.1997 (DAY:258)

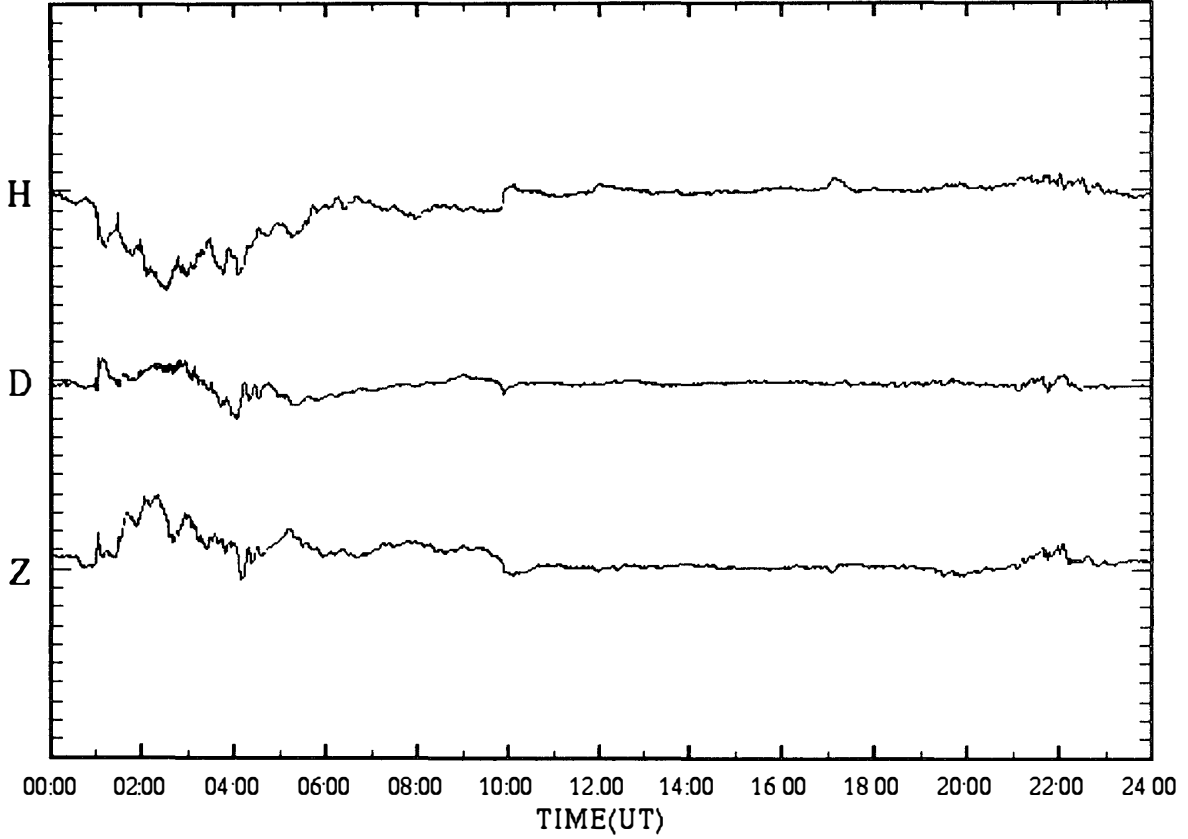

SYOWA magnetogram (100 nT/div)

16 Sep.1997 (DAY:259)

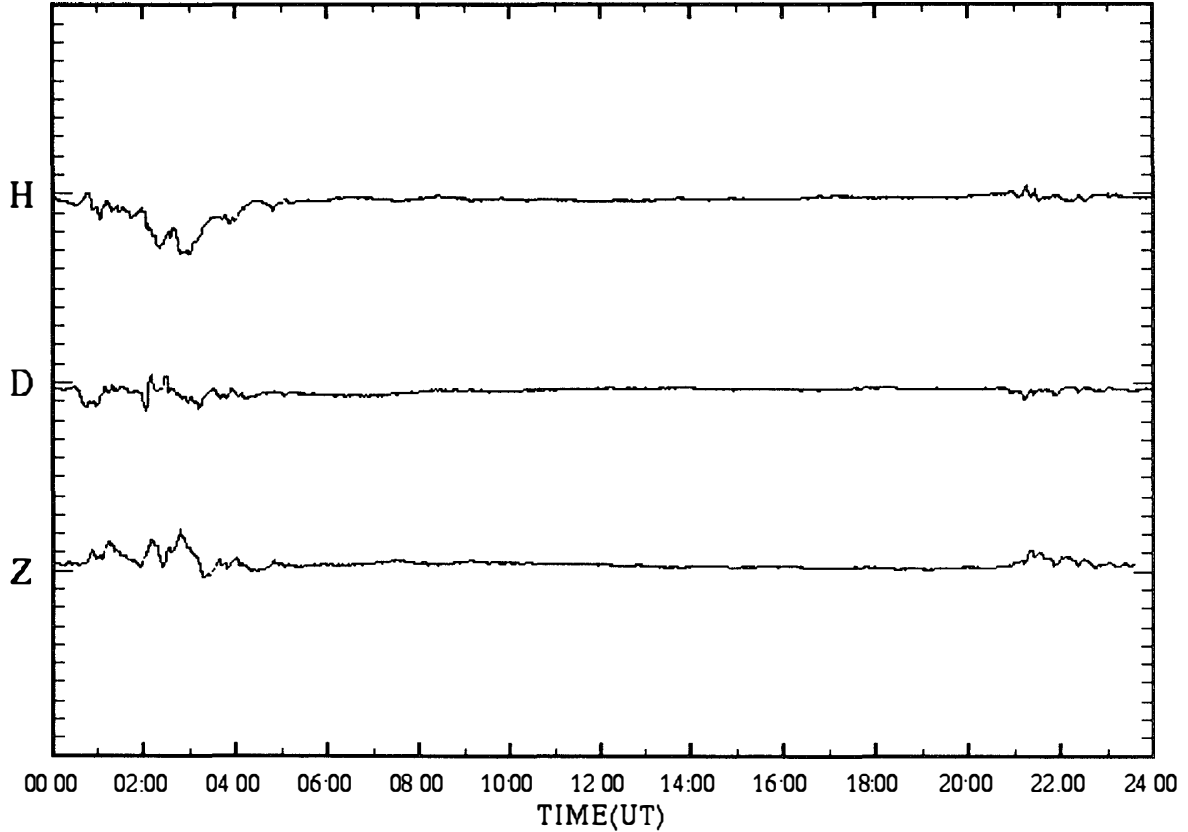

SYOWA magnetogram (100 nT/div)

17 Sep.1997 (DAY:260)

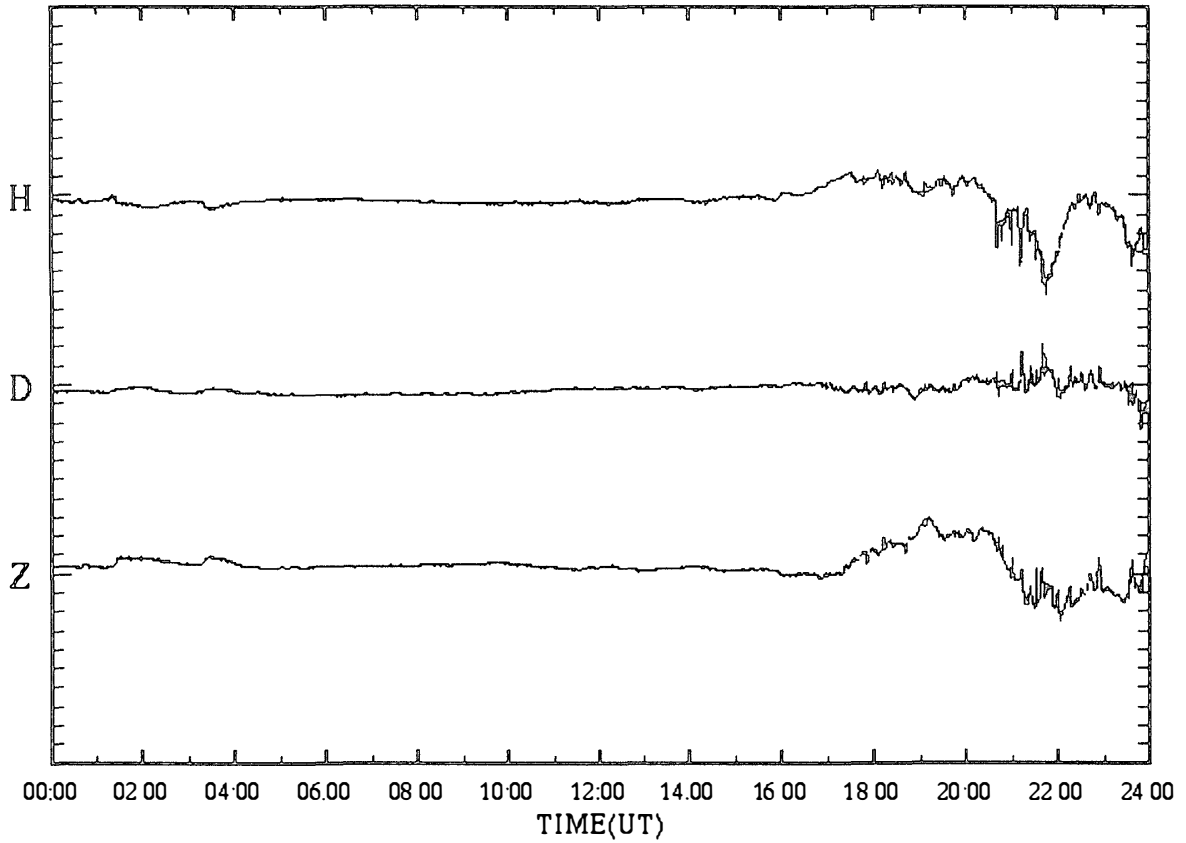

SYOWA magnetogram (100 nT/div)

18 Sep.1997 (DAY:261)

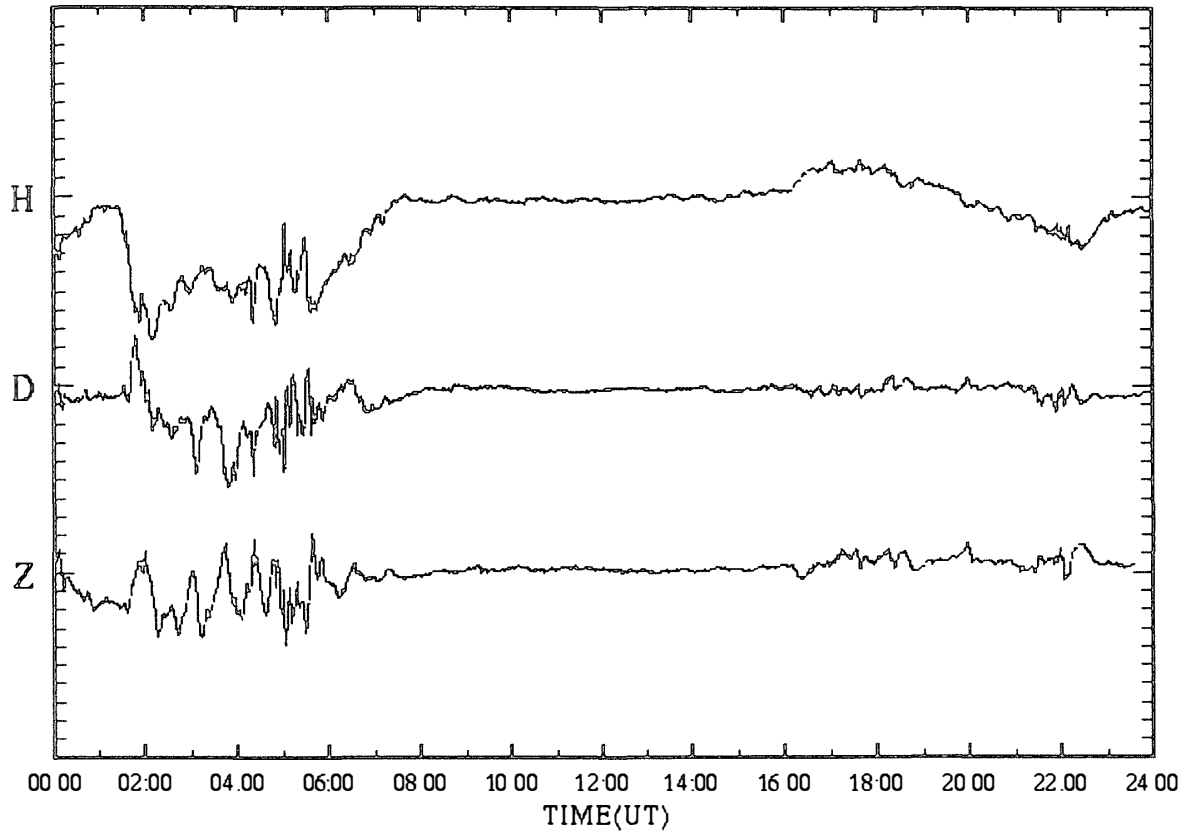



SYOWA magnetogram (100 nT/div)

19 Sep.1997 (DAY:262)

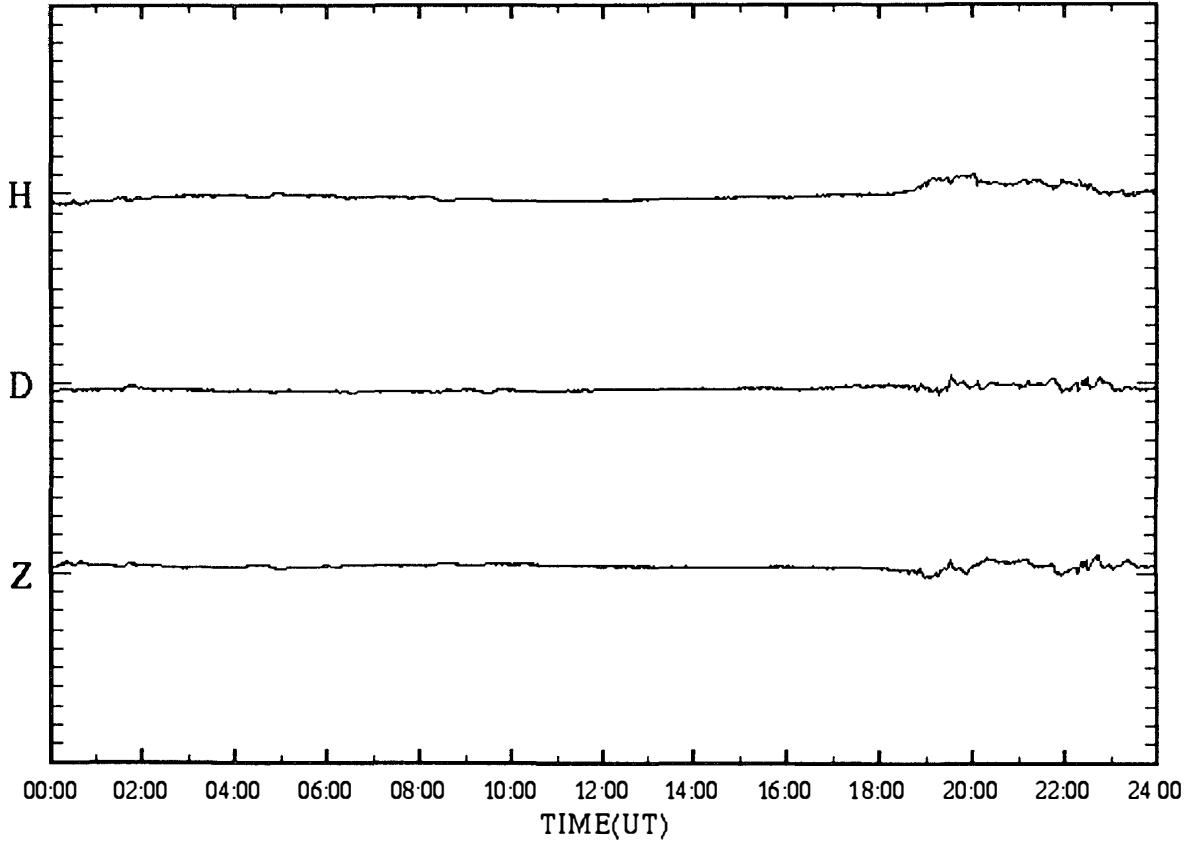

SYOWA magnetogram (100 nT/div)

20 Sep.1997 (DAY:263)

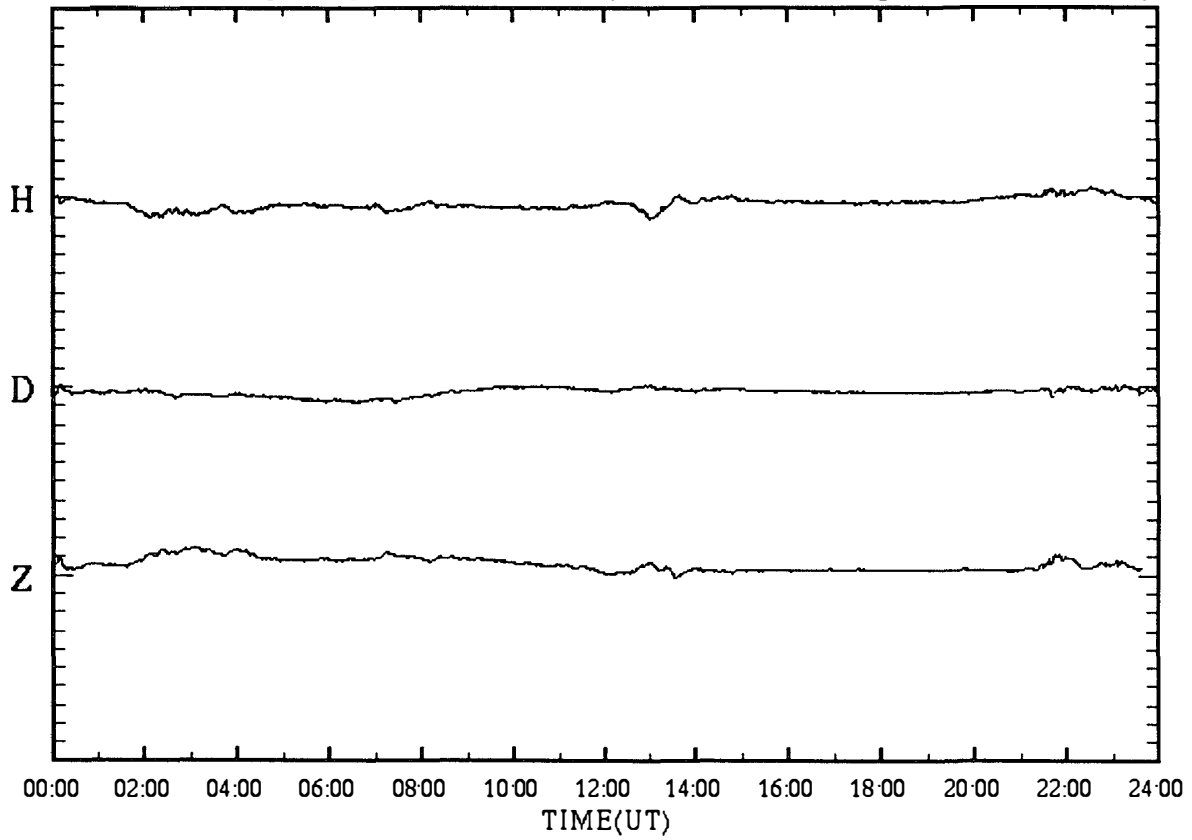

SYOWA magnetogram (100 nT/div)

21 Sep.1997 (DAY:264)

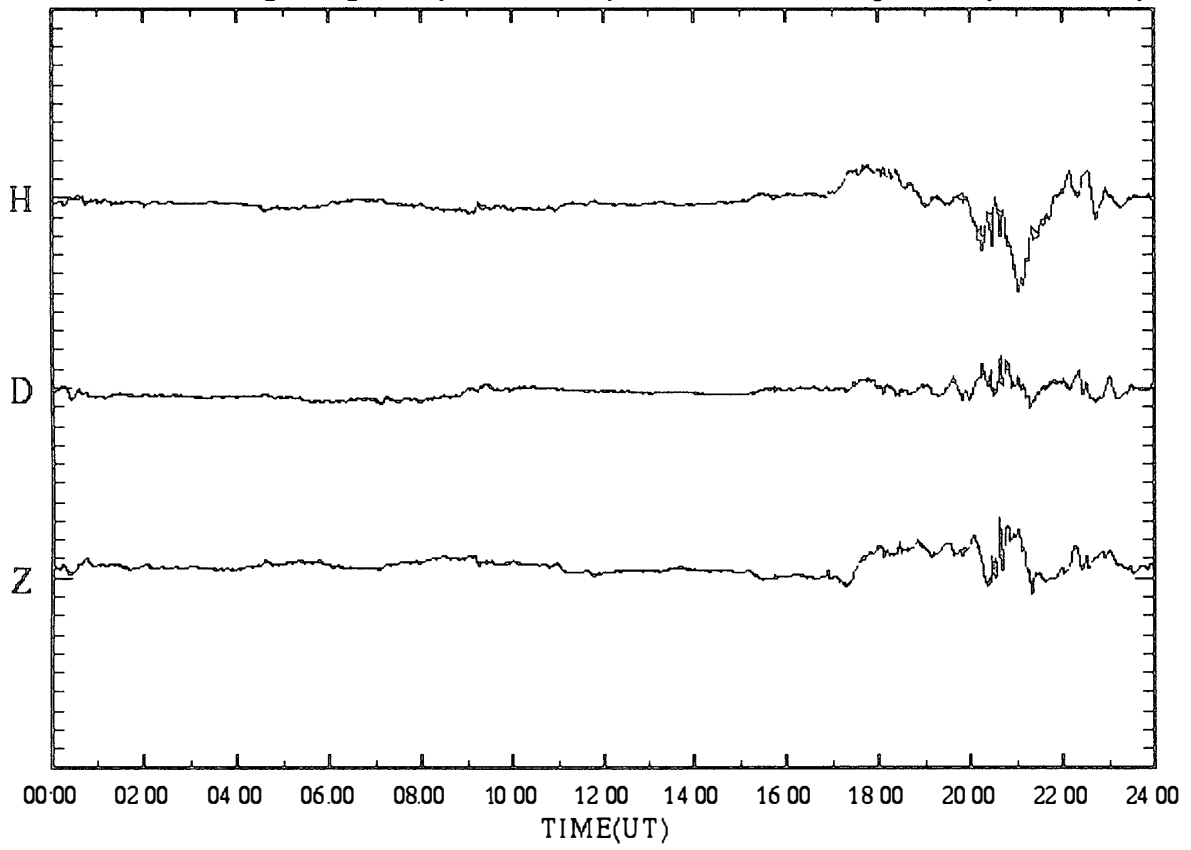

SYOWA magnetogram (100 nT/div)

22 Sep.1997 (DAY:265)

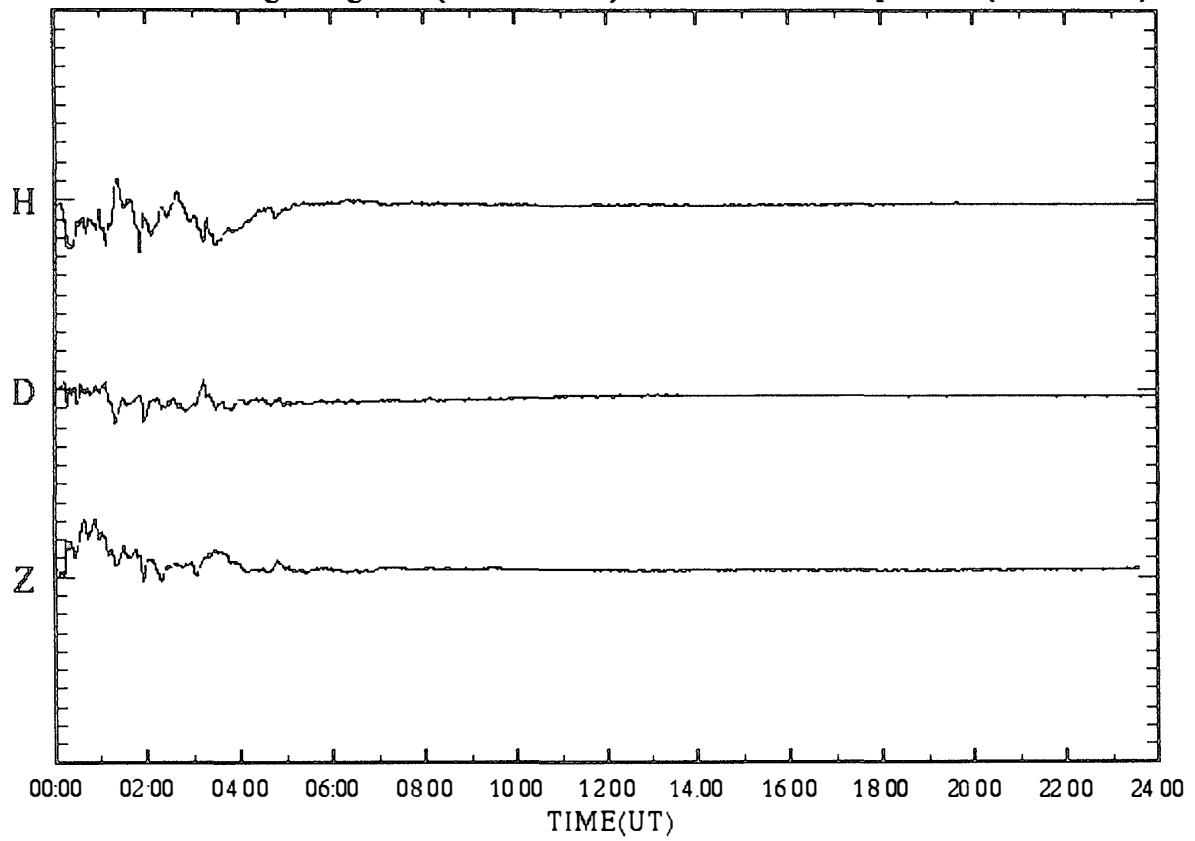

SYOWA magnetogram (100 nT/div)

23 Sep.1997 (DAY:266)

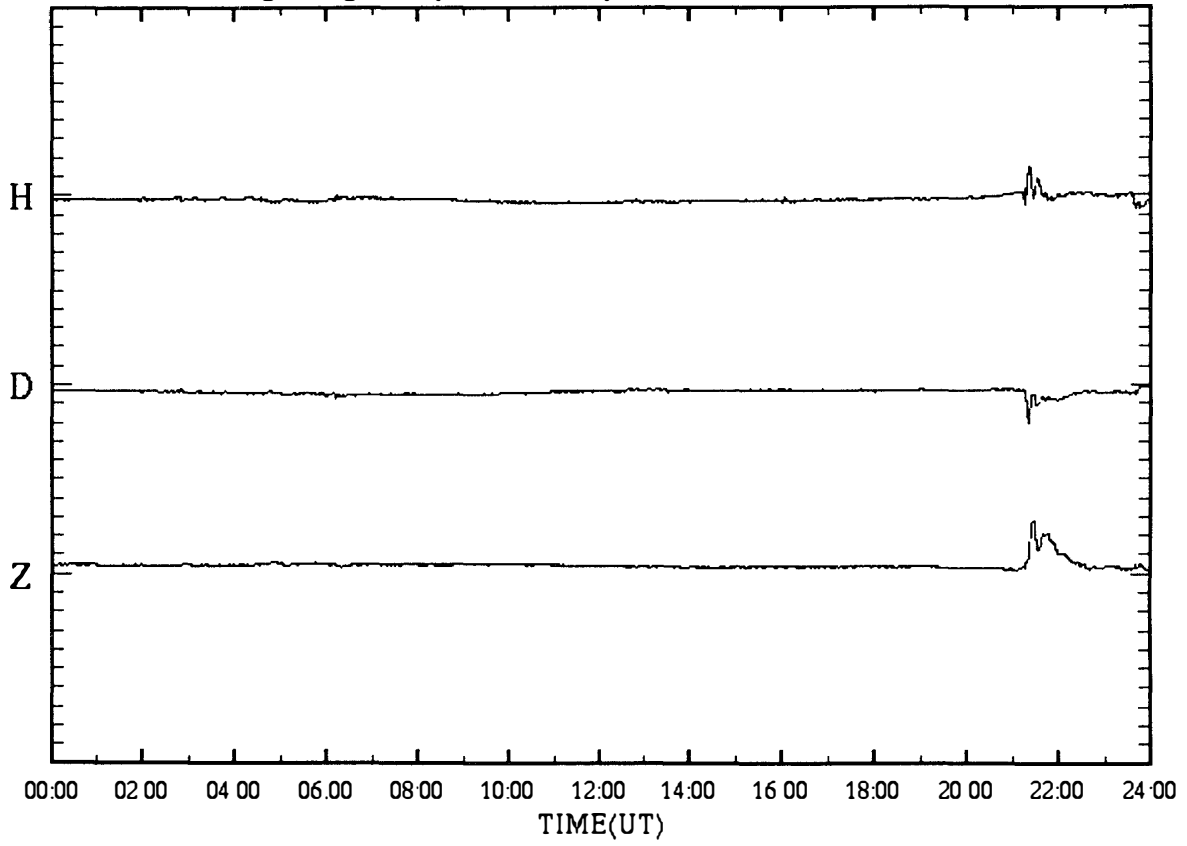

SYOWA magnetogram (100 nT/div)

24 Sep.1997 (DAY:267)

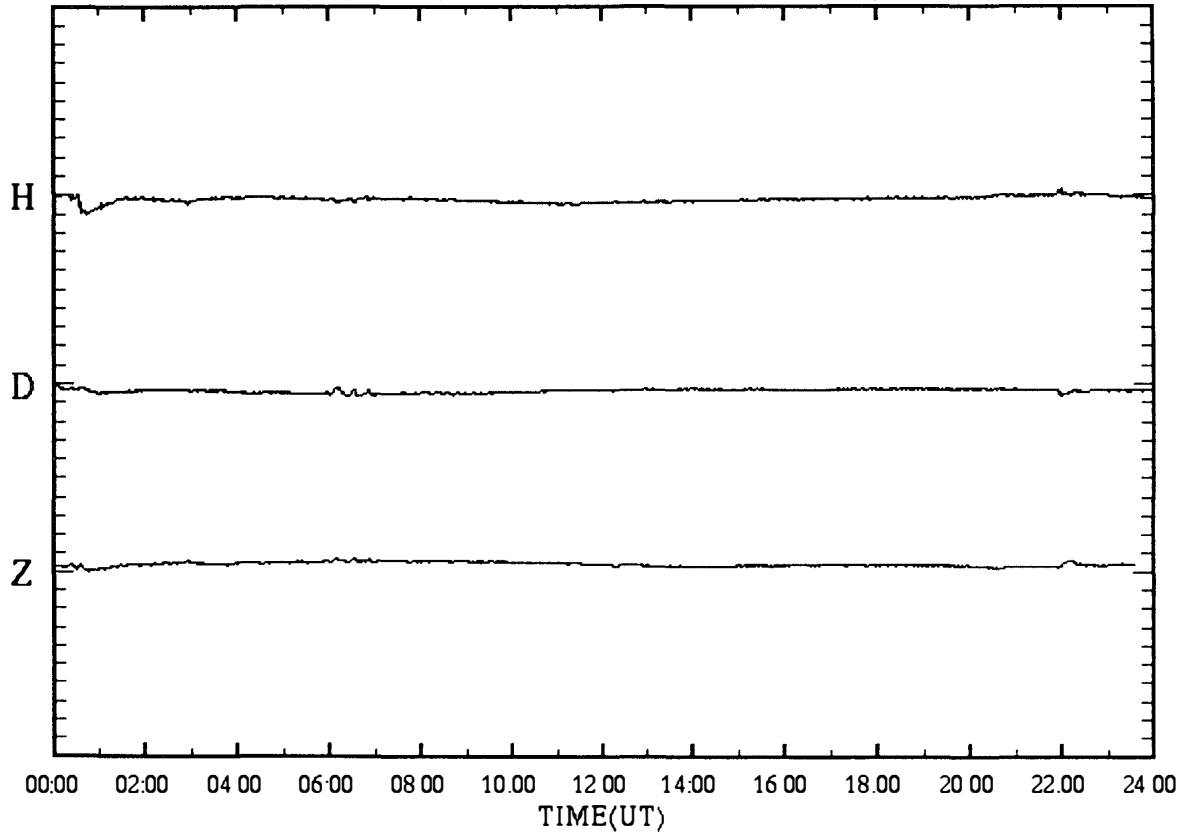

SYOWA magnetogram (100 nT/div)

25 Sep.1997 (DAY:268)

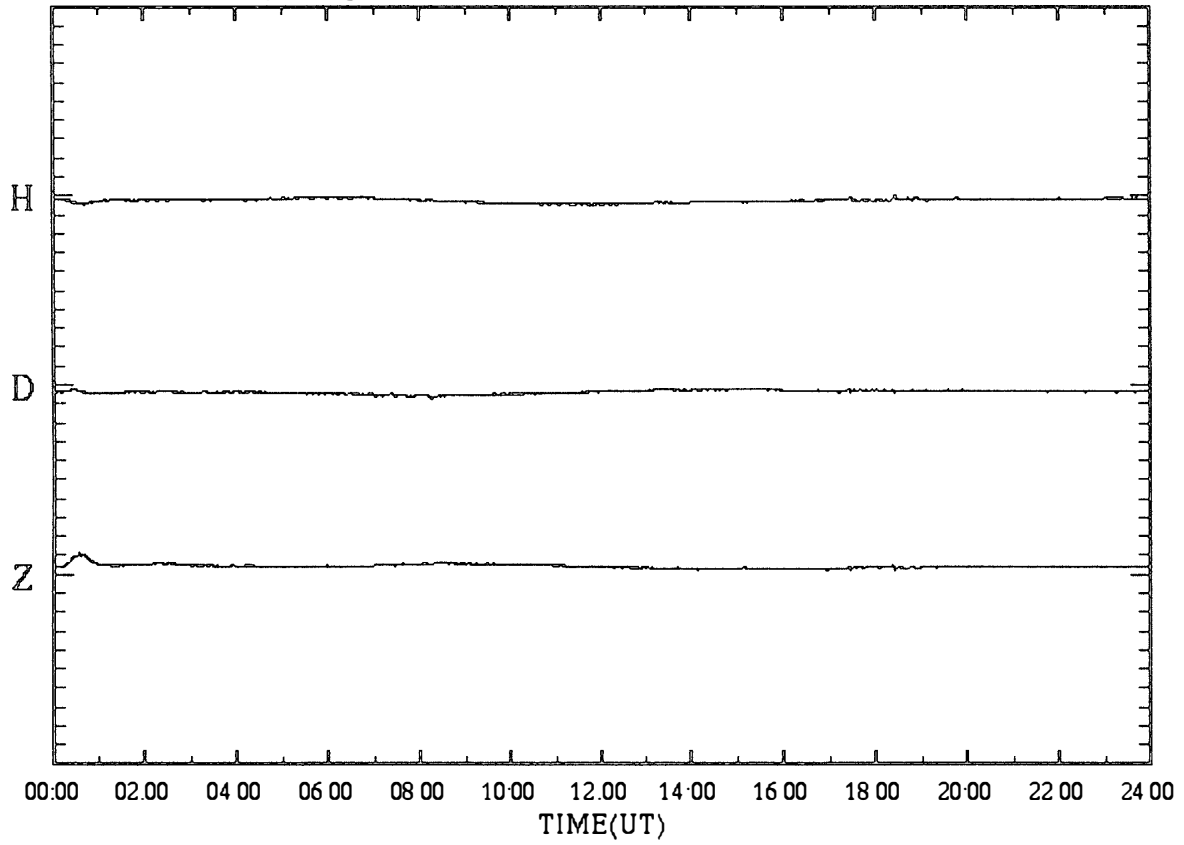

SYOWA magnetogram (100 nT/div)

26 Sep.1997 (DAY:269)

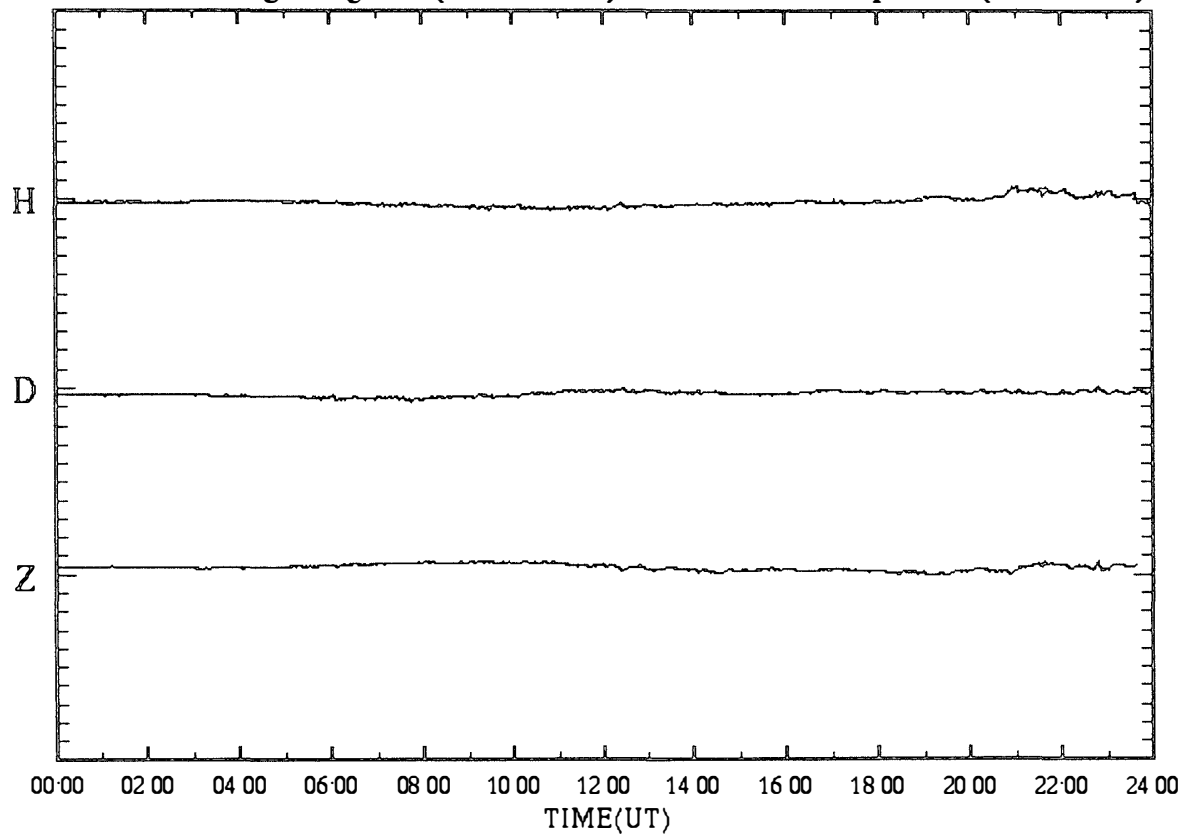

SYOWA magnetogram (100 nT/div)

27 Sep.1997 (DAY:270)

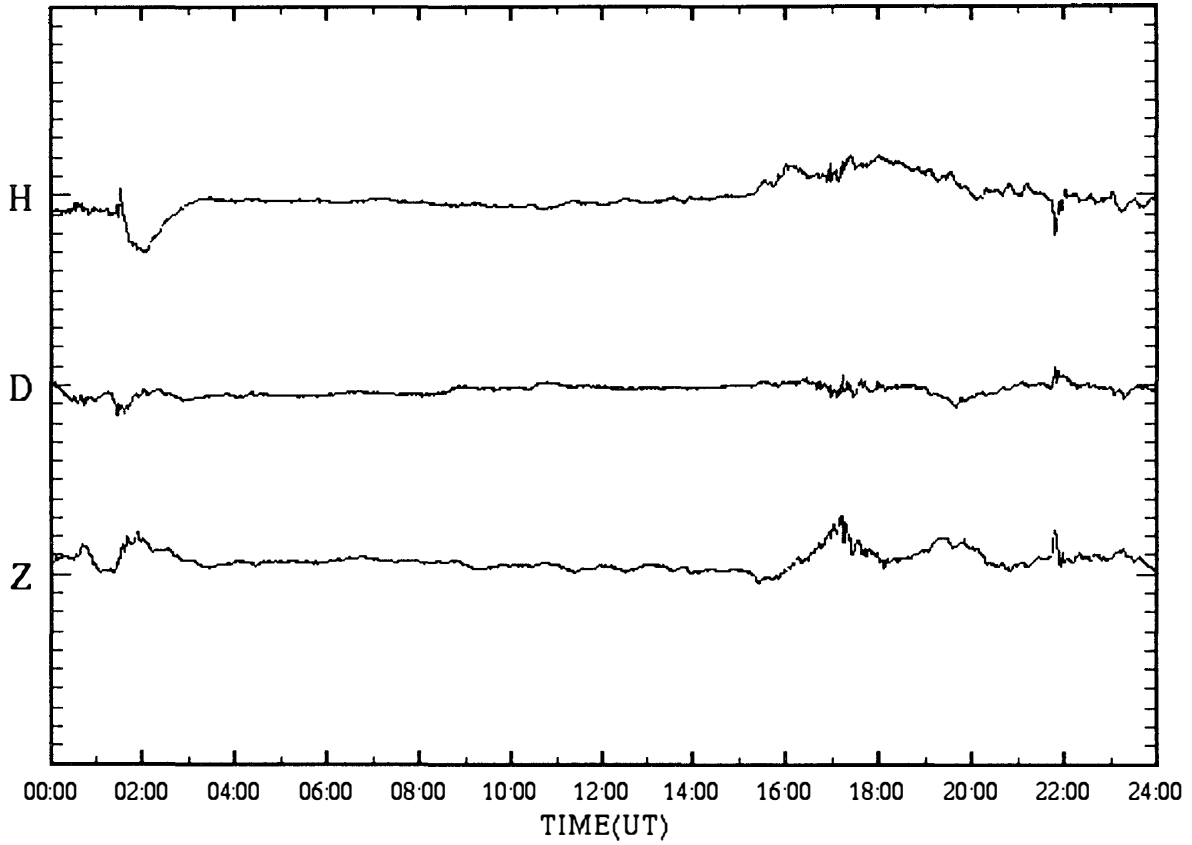

SYOWA magnetogram (100 nT/div)

28 Sep.1997 (DAY:271)

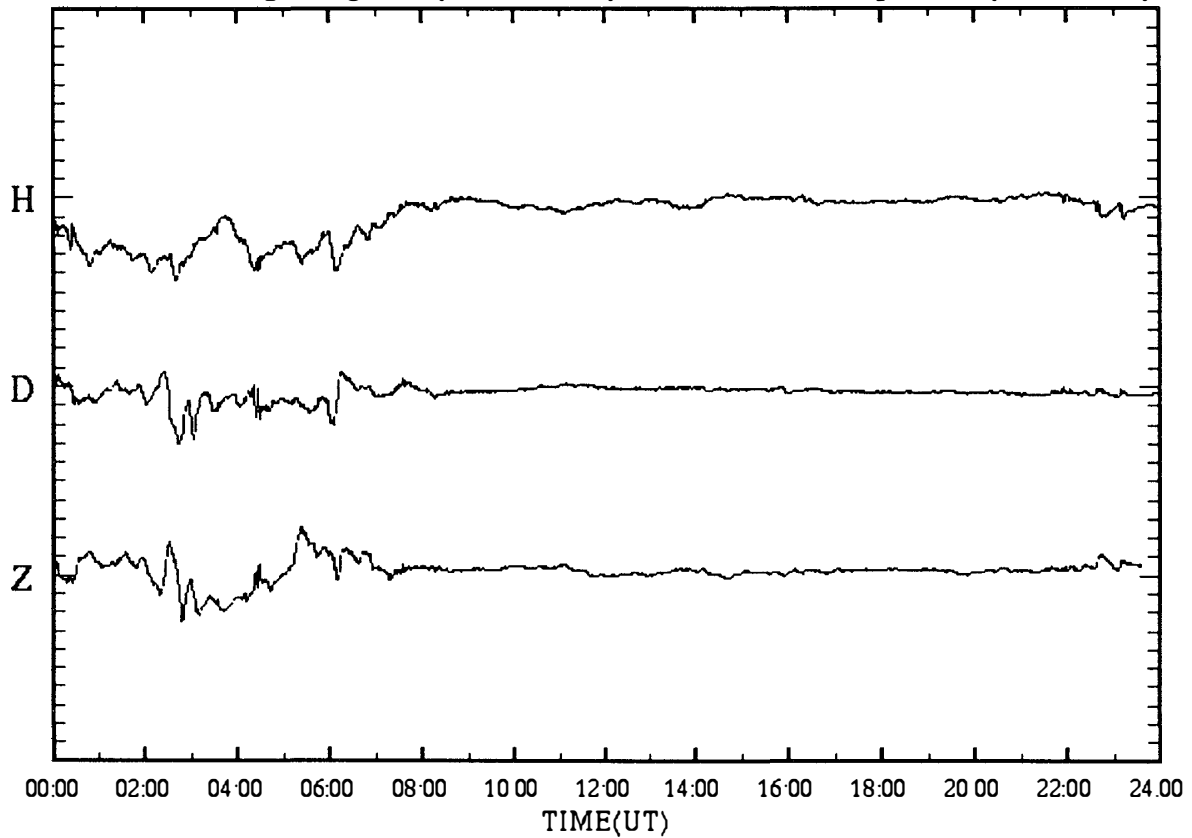

SYOWA magnetogram (100 nT/div)

29 Sep.1997 (DAY:272)

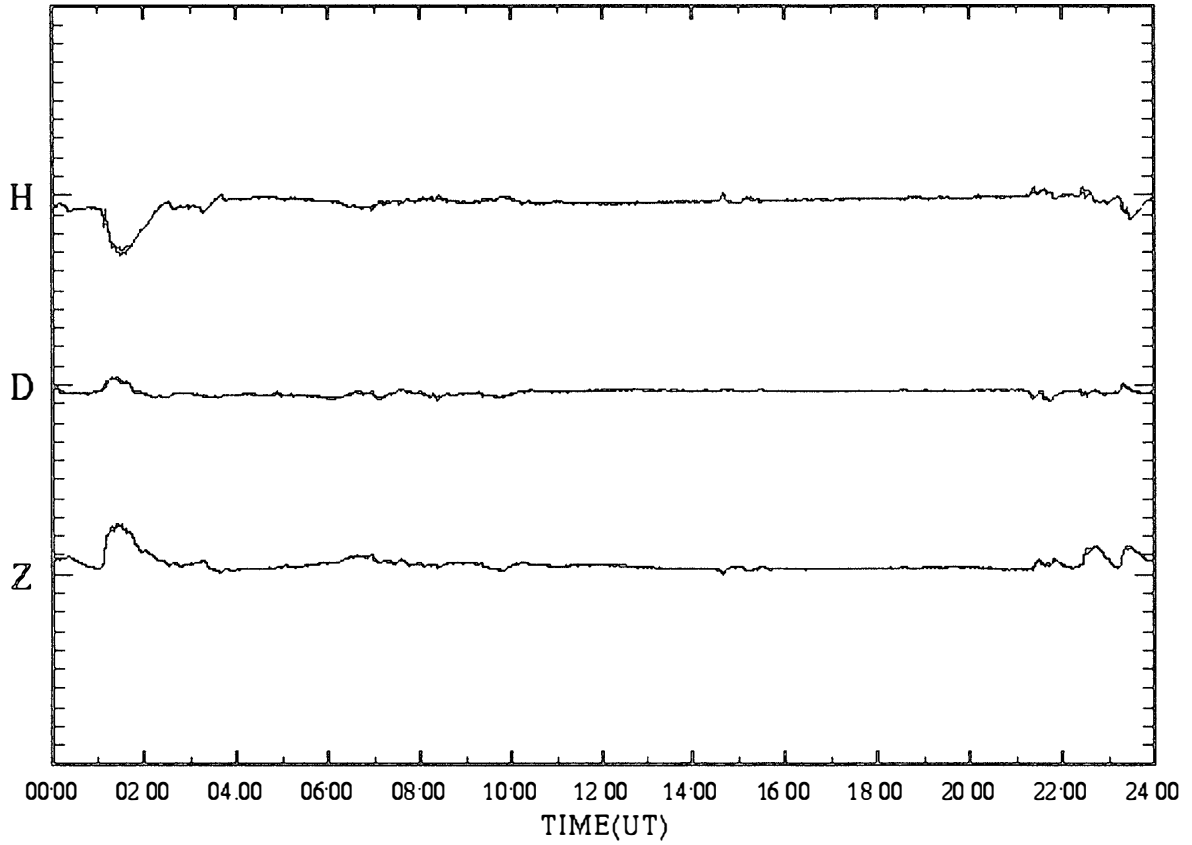

SYOWA magnetogram (100 nT/div)

30 Sep.1997 (DAY:273)

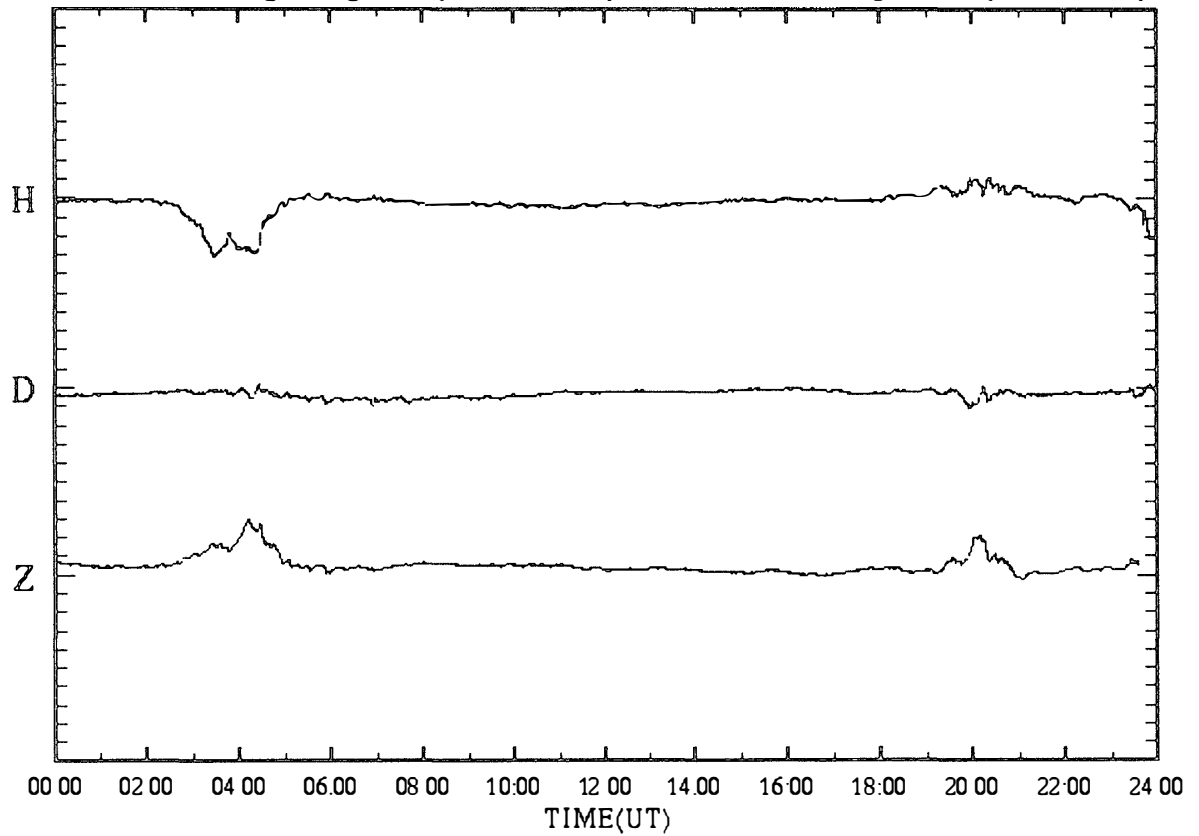

SYOWA magnetogram (100 nT/div)

01 Oct.1997 (DAY:274)

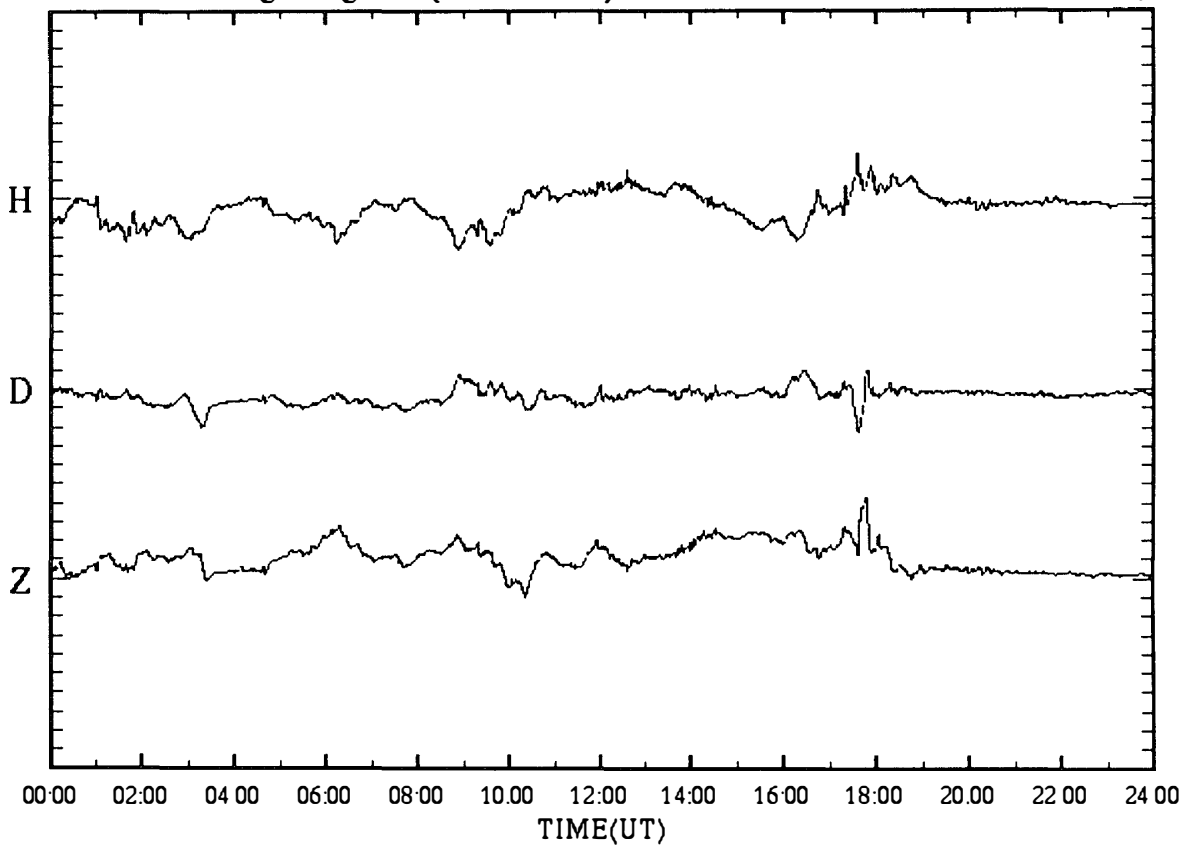

SYOWA magnetogram (100 nT/div)

02 Oct.1997 (DAY:275)

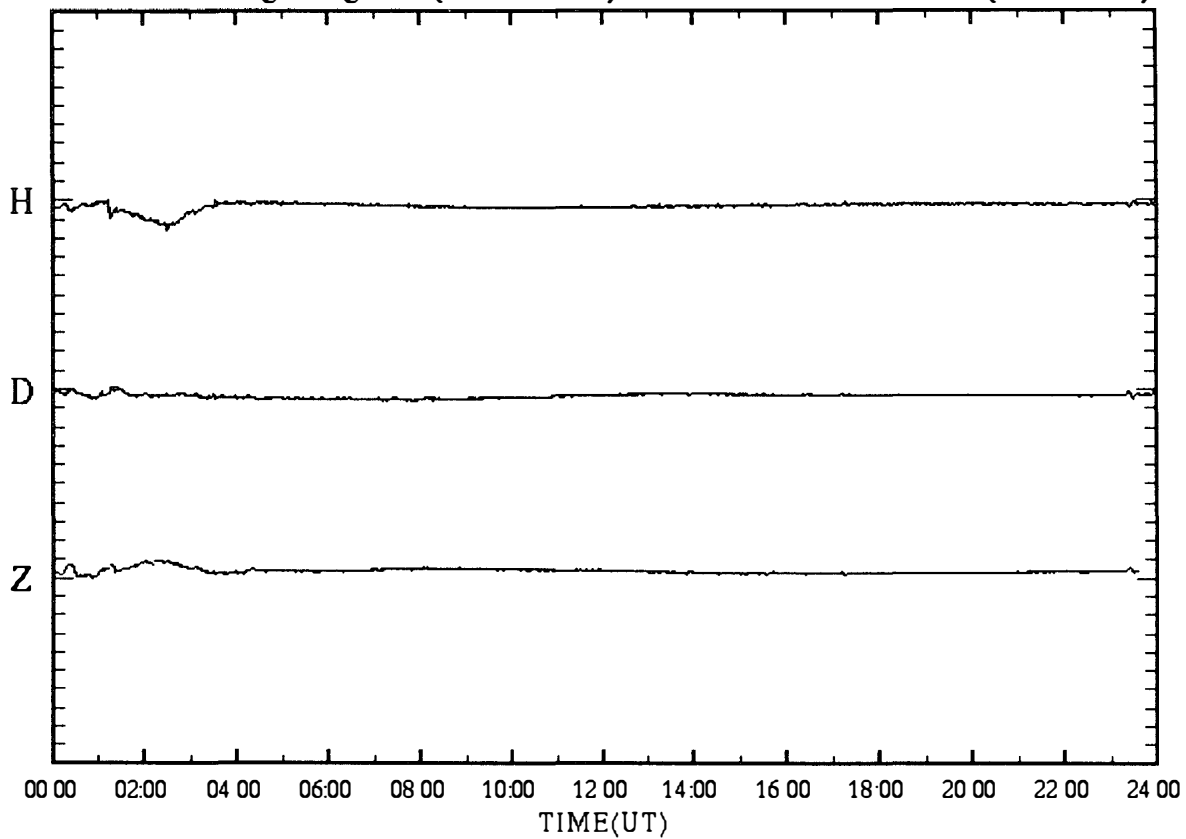

SYOWA magnetogram (100 nT/div)

03 Oct.1997 (DAY:276)

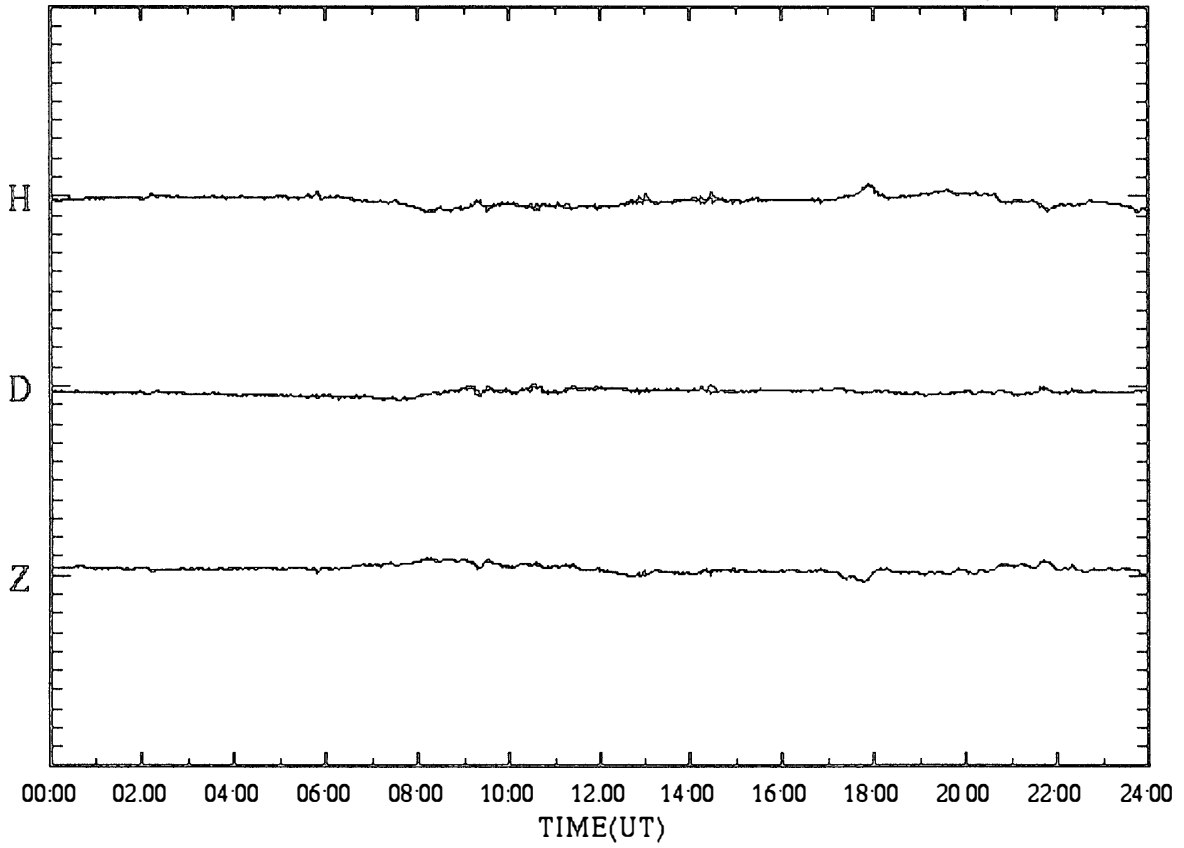

SYOWA magnetogram (100 nT/div)

04 Oct.1997 (DAY:277)

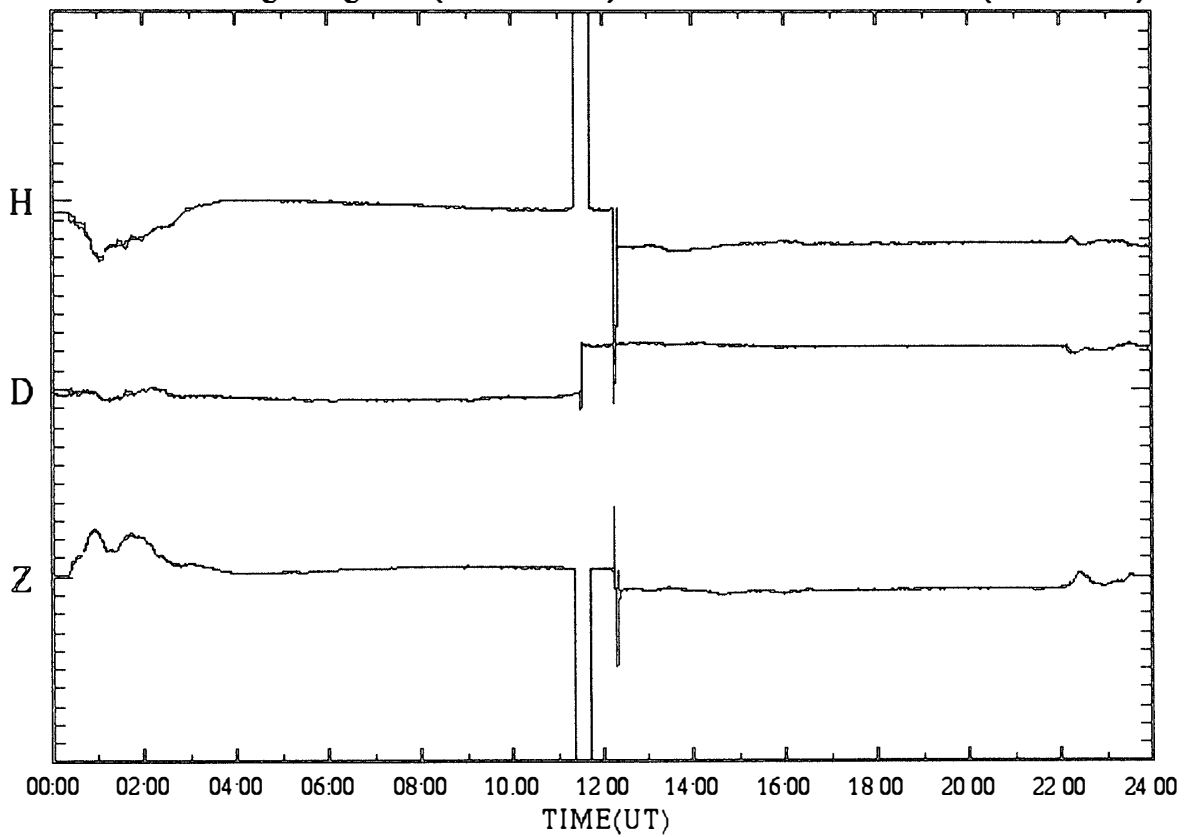



SYOWA magnetogram (100 nT/div)

05 Oct.1997 (DAY:278)

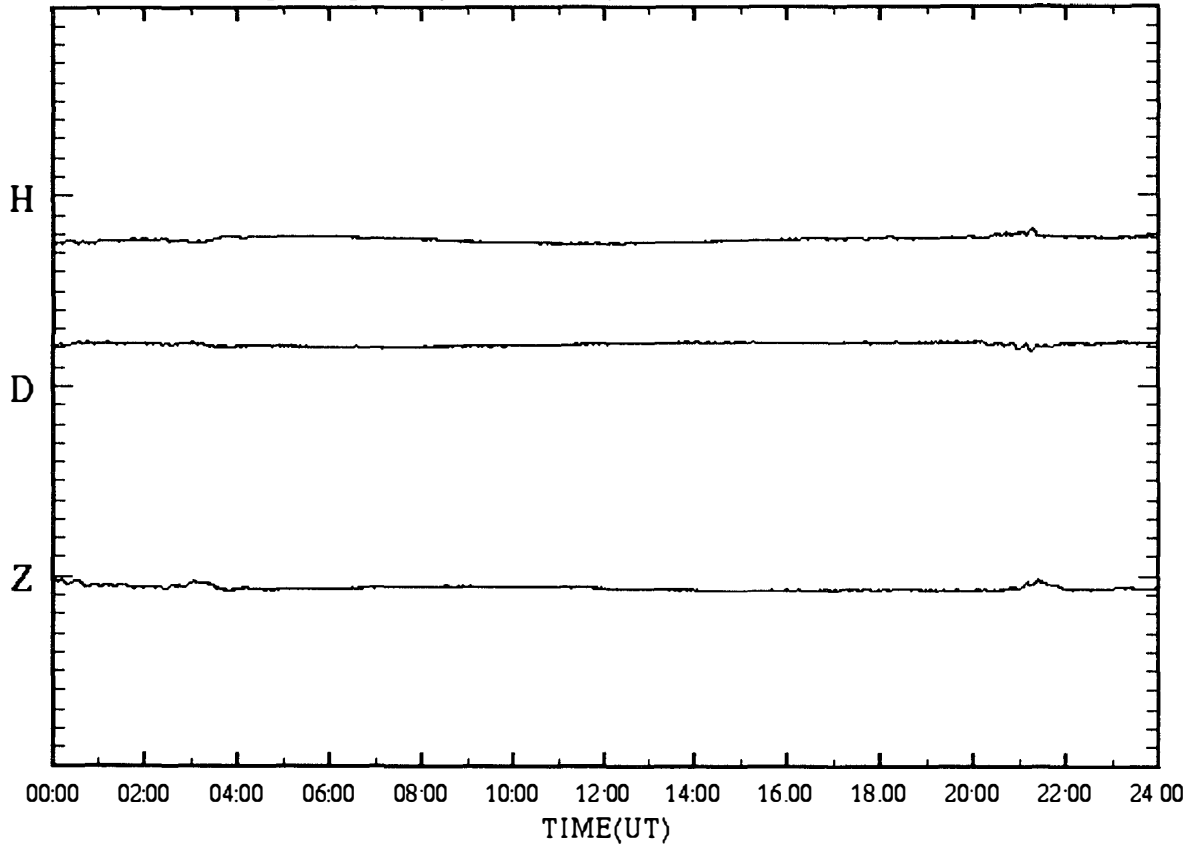

SYOWA magnetogram (100 nT/div)

06 Oct.1997 (DAY:279)

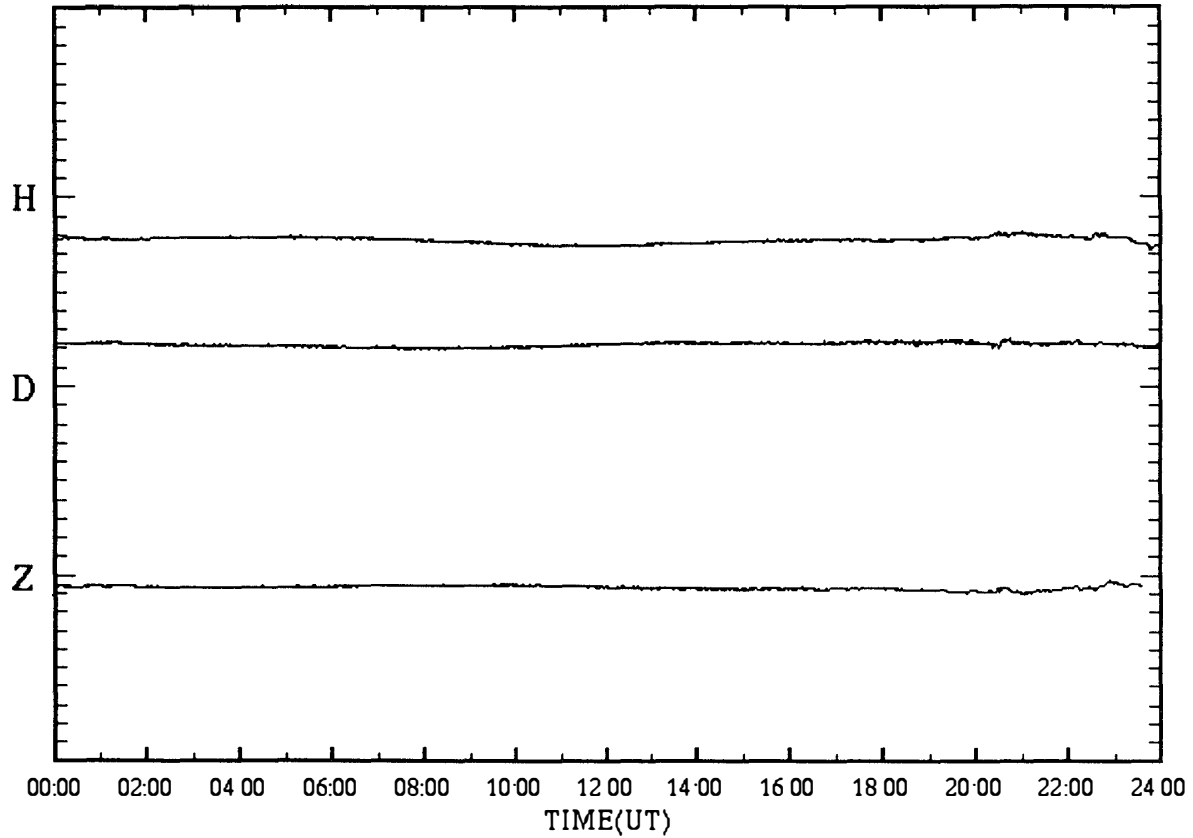

SYOWA magnetogram (100 nT/div)

07 Oct.1997 (DAY:280)

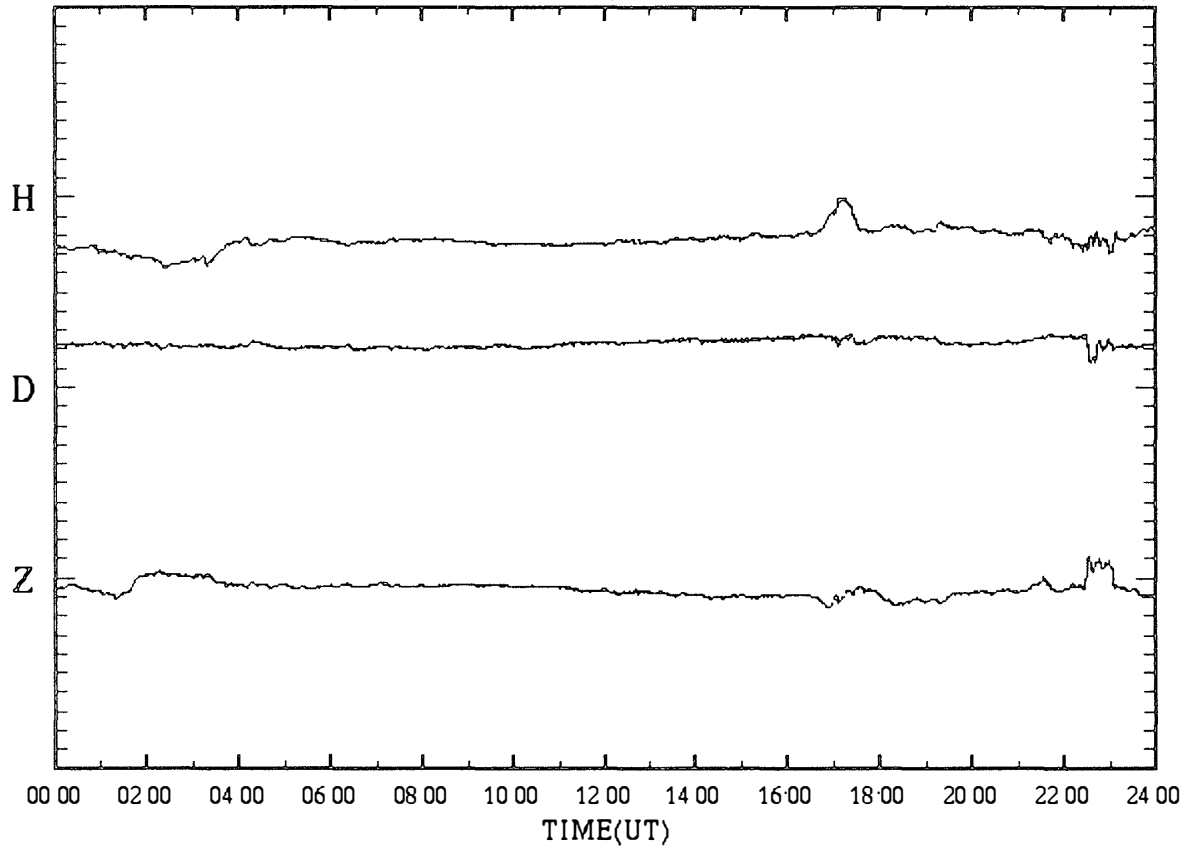

SYOWA magnetogram (100 nT/div)

08 Oct.1997 (DAY:281)

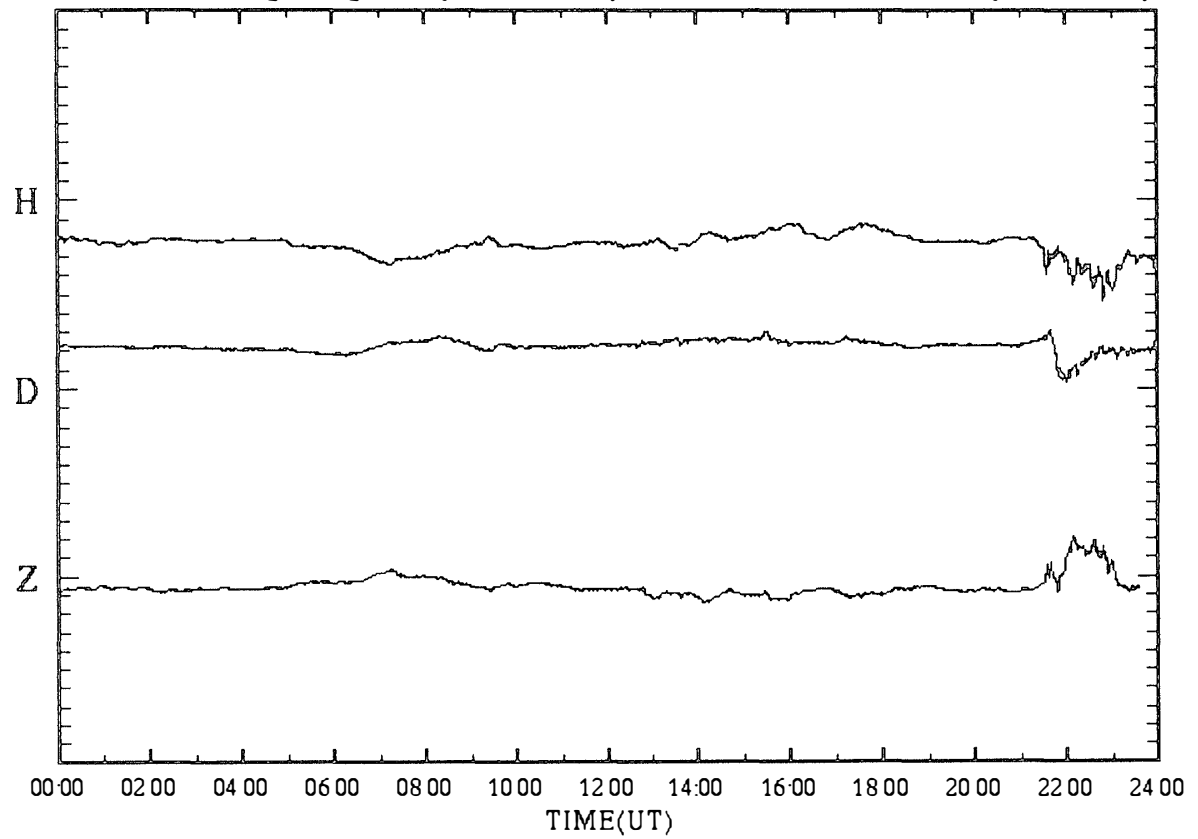

SYOWA magnetogram (100 nT/div)

09 Oct.1997 (DAY:282)

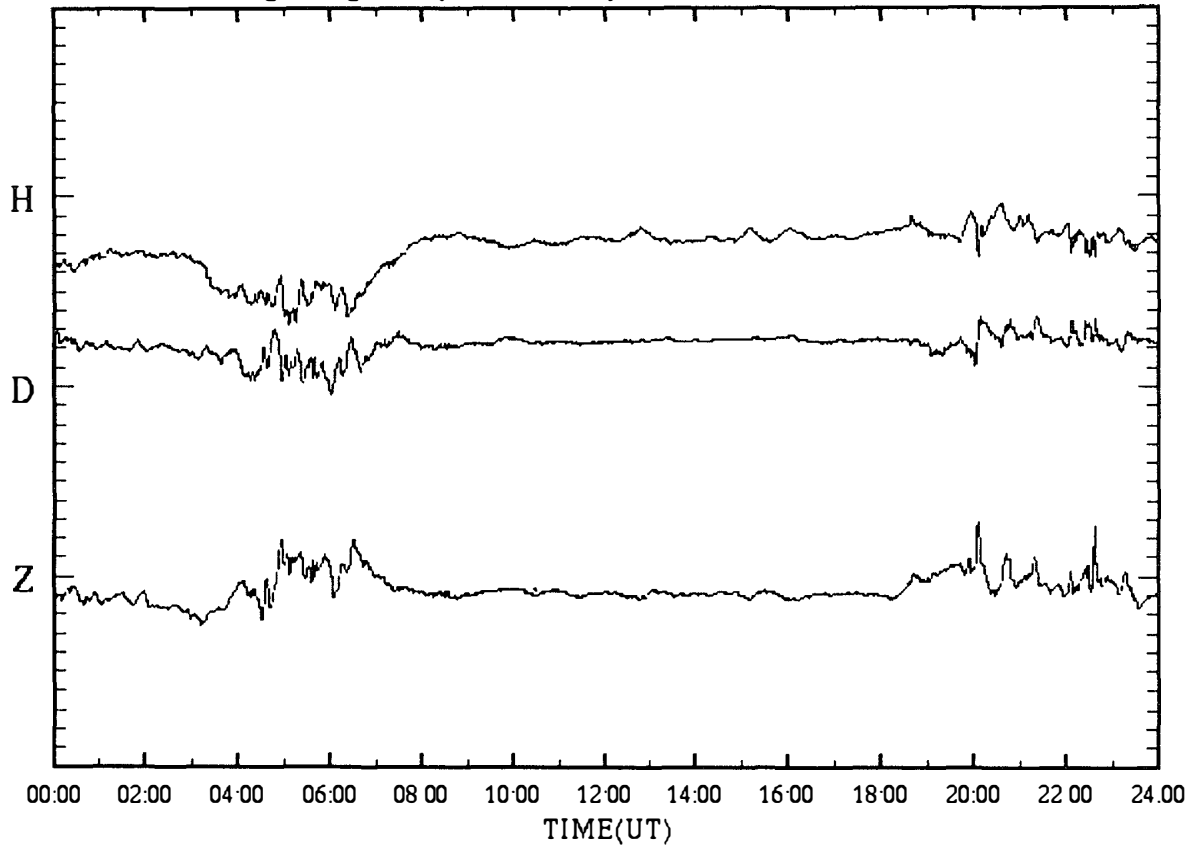

SYOWA magnetogram (100 nT/div)

10 Oct.1997 (DAY:283)

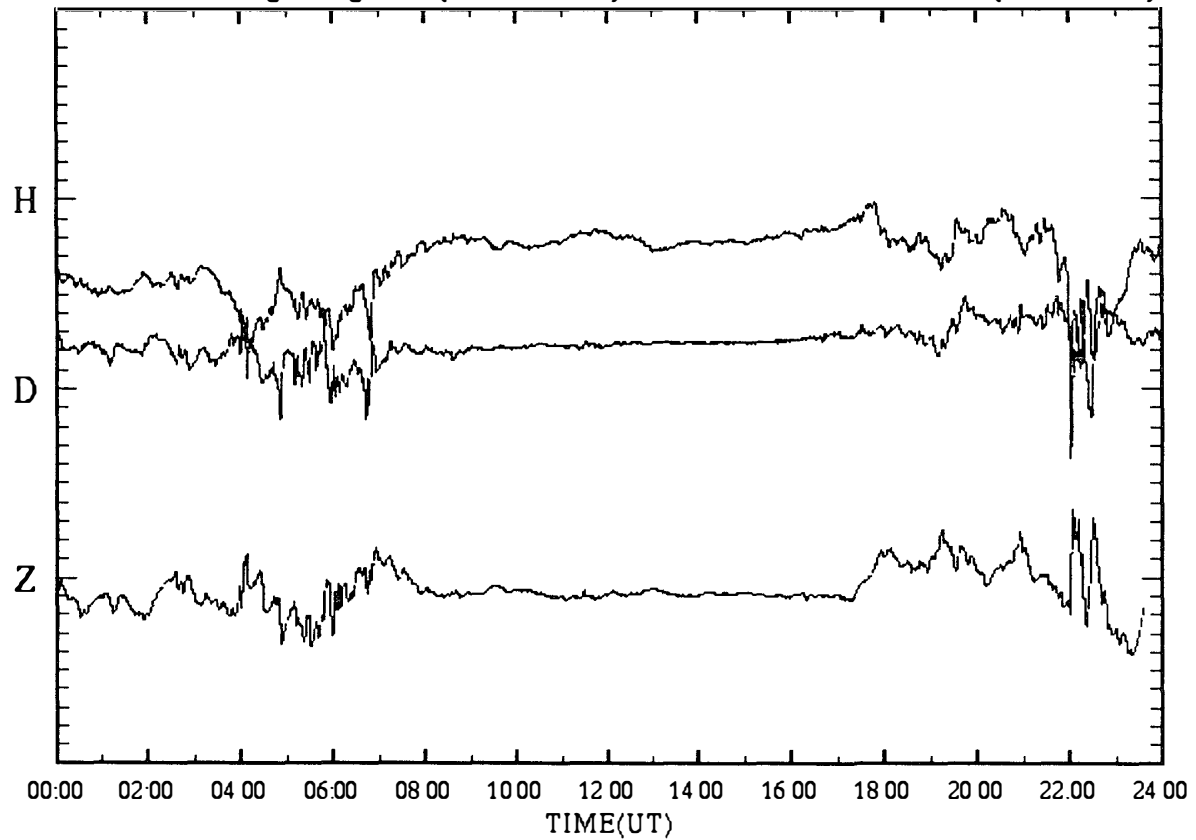

SYOWA magnetogram (100 nT/div)

11 Oct.1997 (DAY:284)

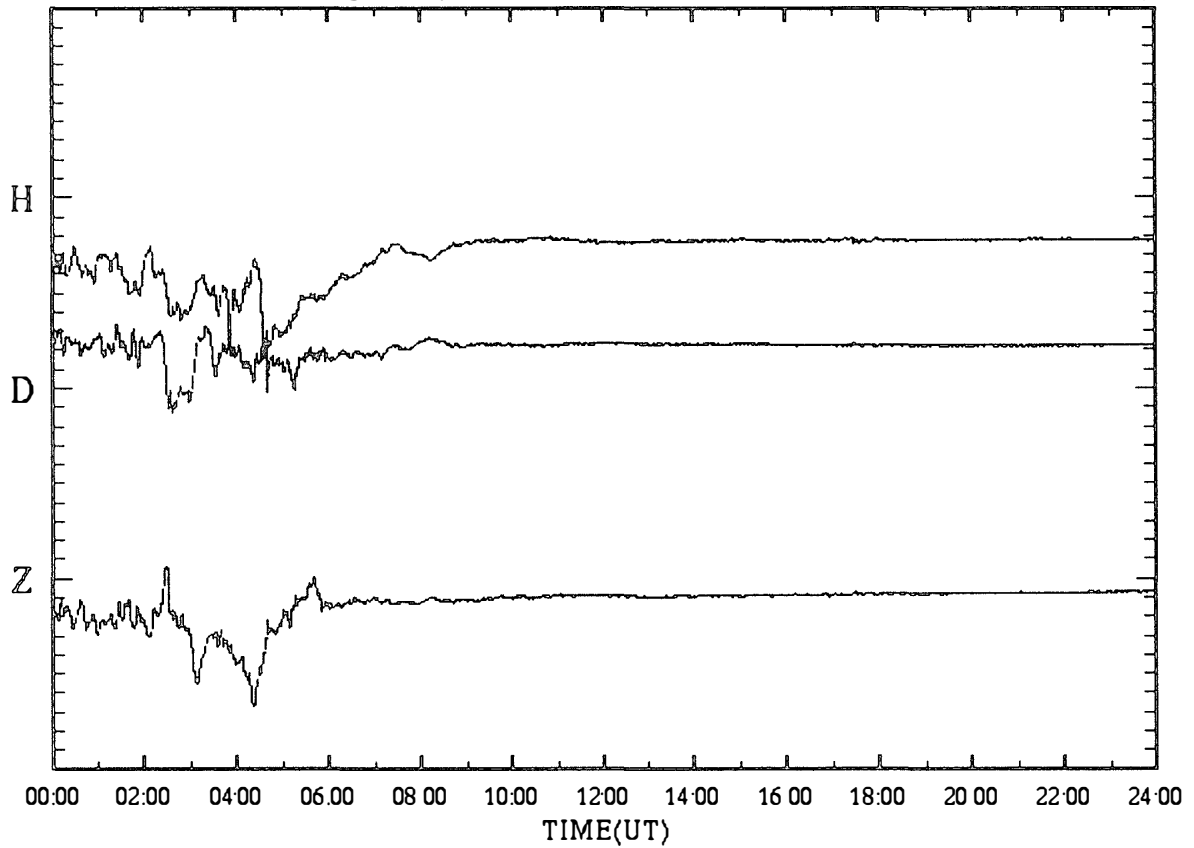

SYOWA magnetogram (100 nT/div)

12 Oct.1997 (DAY:285)

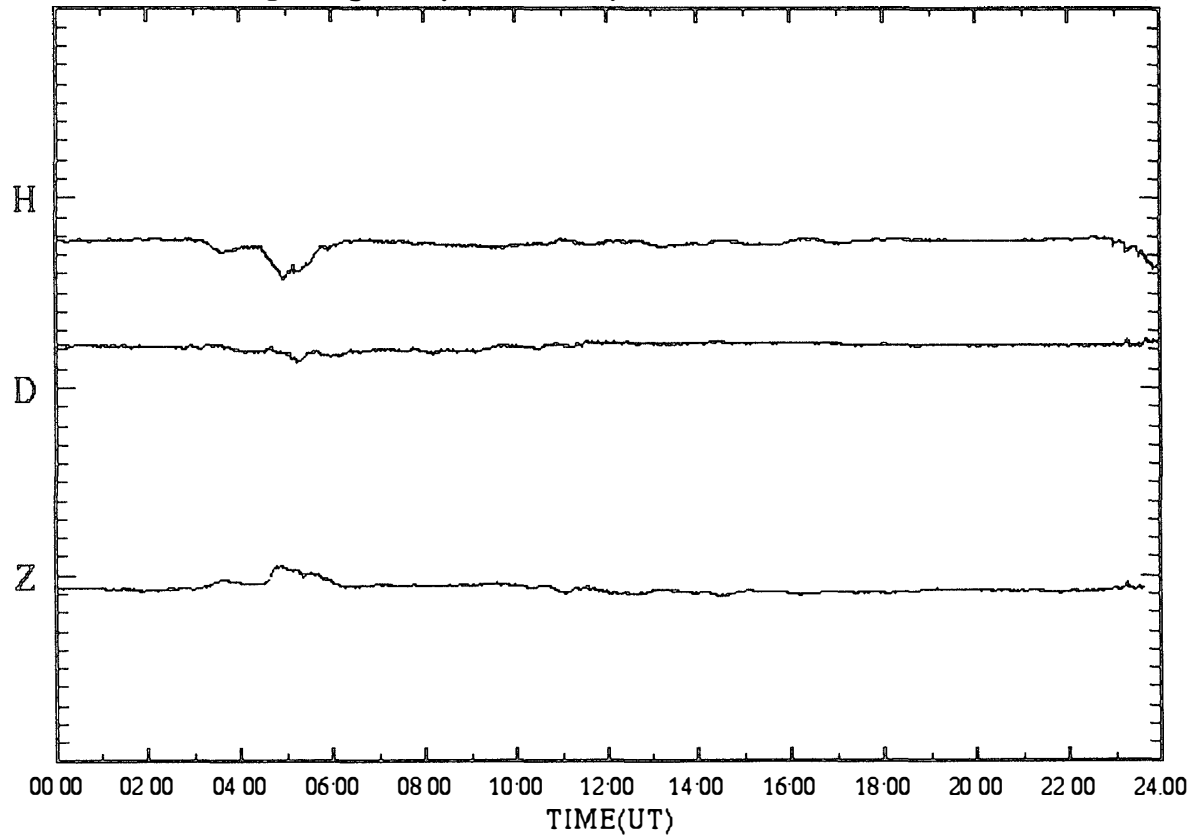

SYOWA magnetogram (100 nT/div)

13 Oct.1997 (DAY:286)

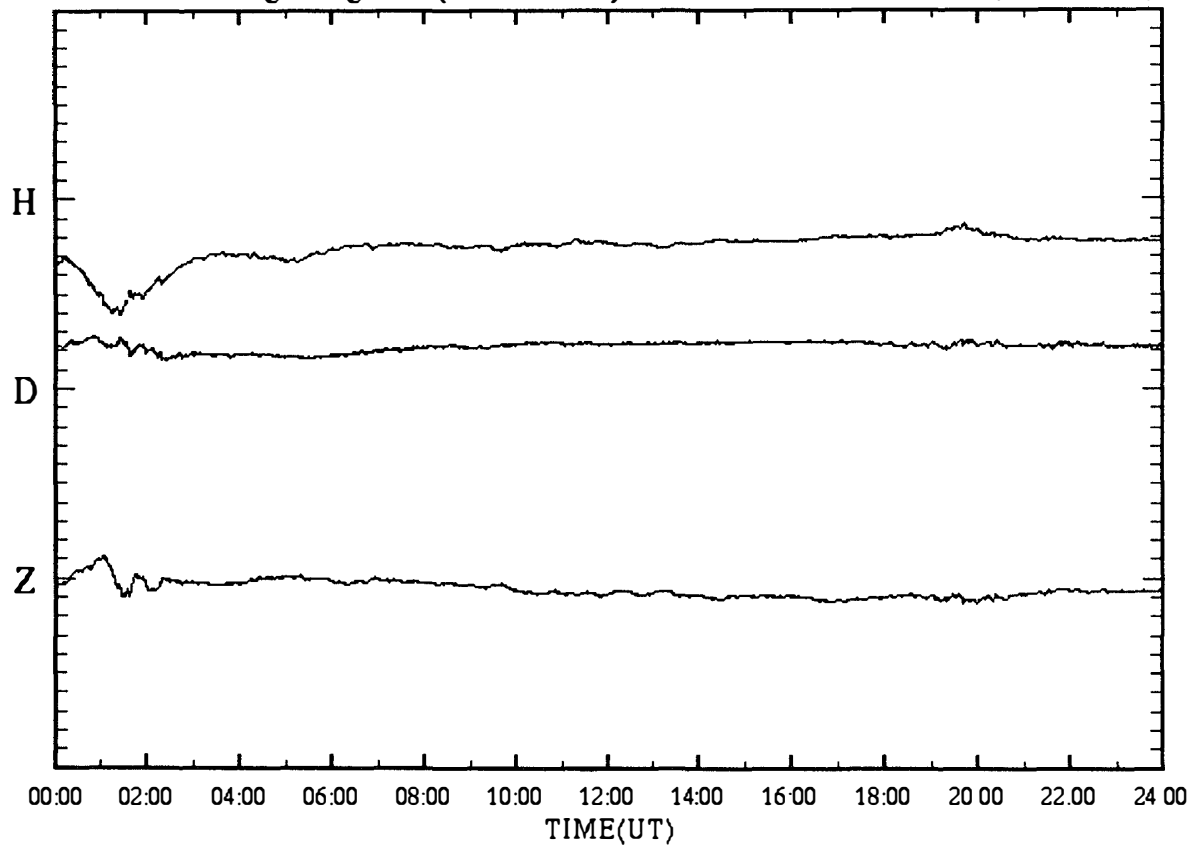

SYOWA magnetogram (100 nT/div)

14 Oct.1997 (DAY:287)

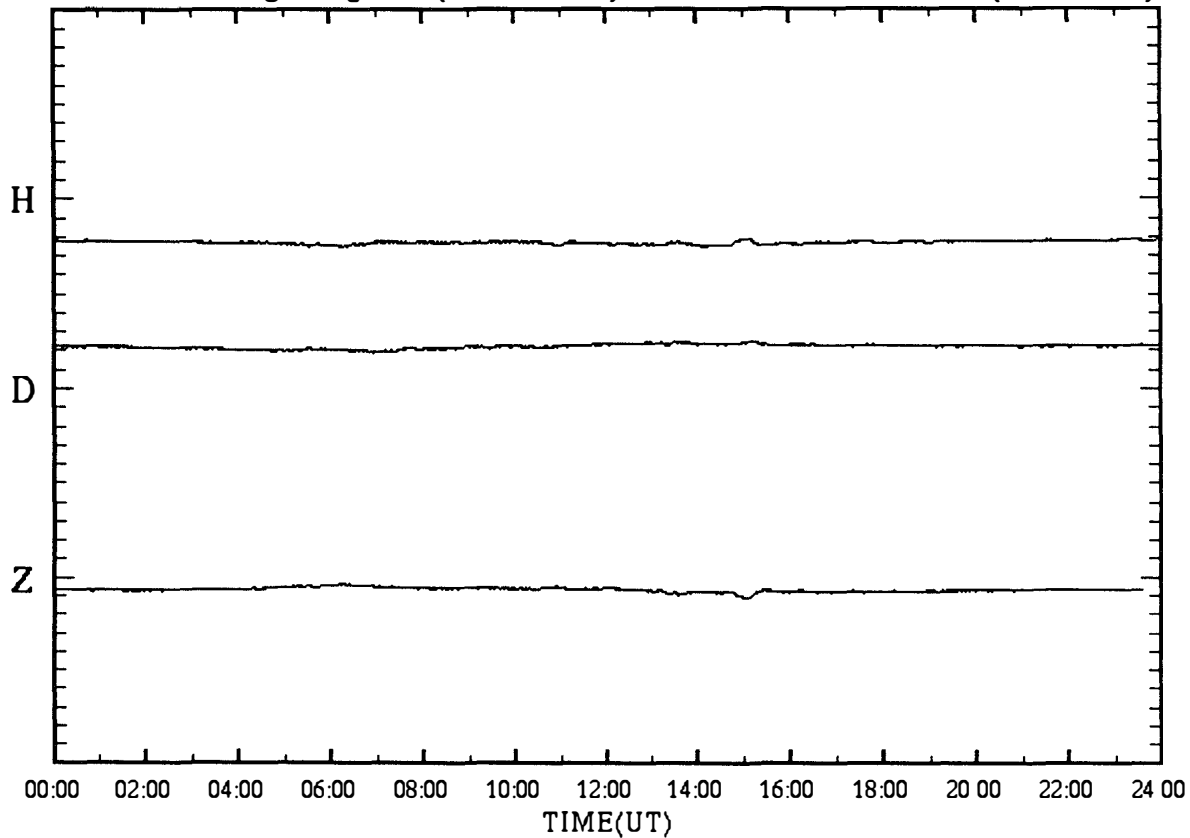

SYOWA magnetogram (100 nT/div)

15 Oct.1997 (DAY:288)

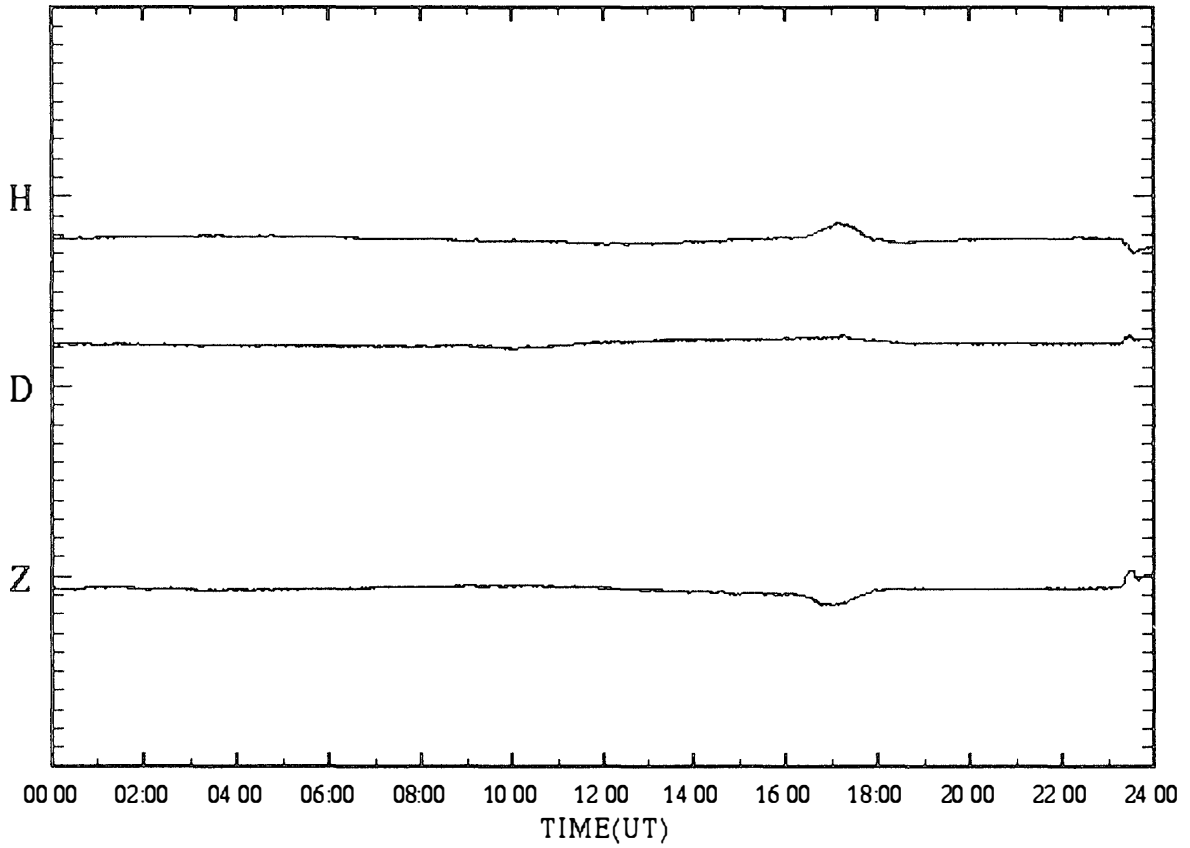

SYOWA magnetogram (100 nT/div)

16 Oct.1997 (DAY:289)

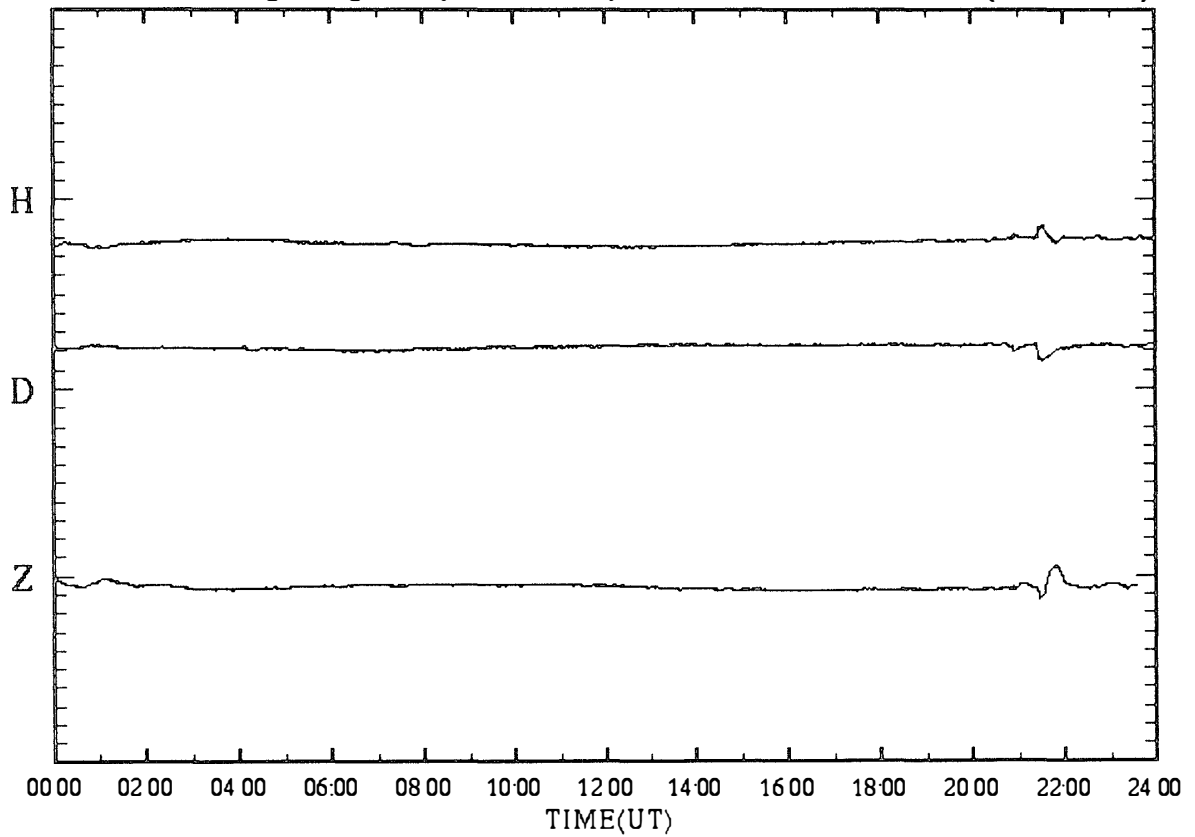

SYOWA magnetogram (100 nT/div)

17 Oct.1997 (DAY:290)

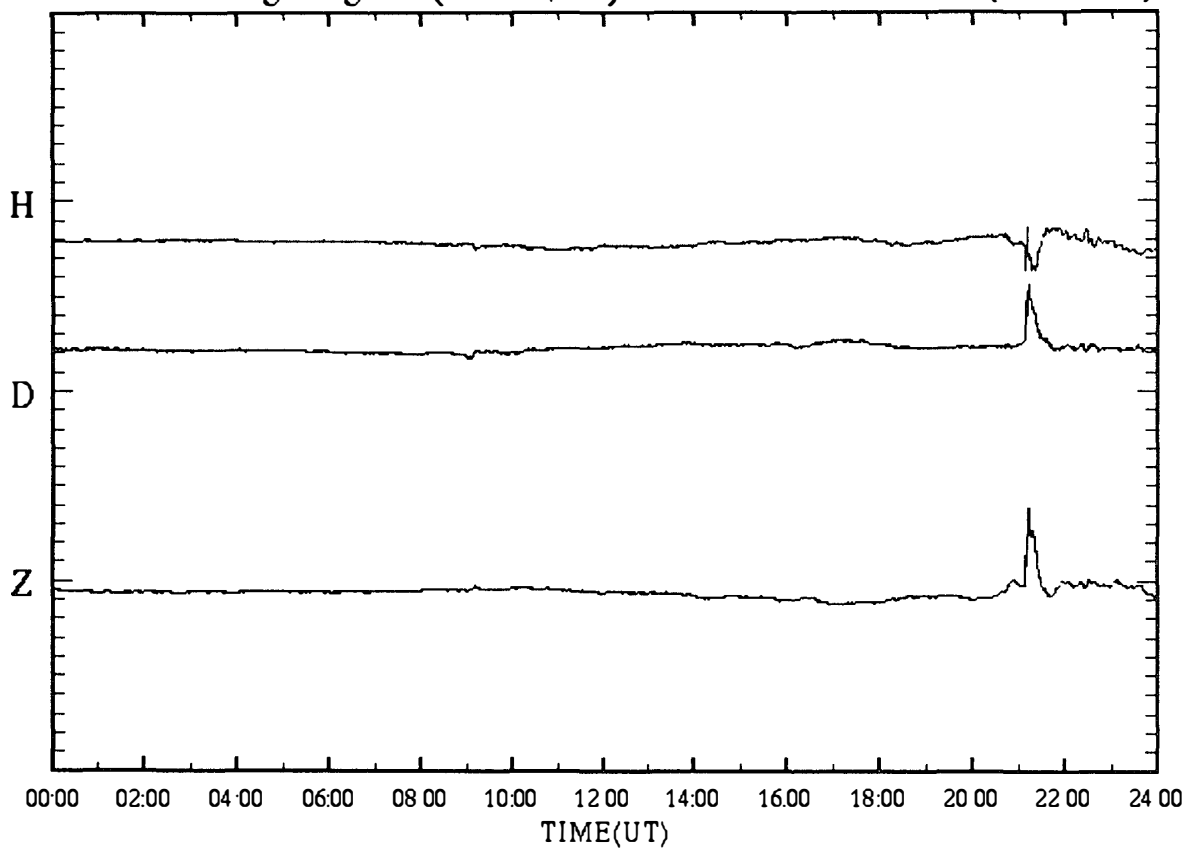

SYOWA magnetogram (100 nT/div)

18 Oct.1997 (DAY:291)

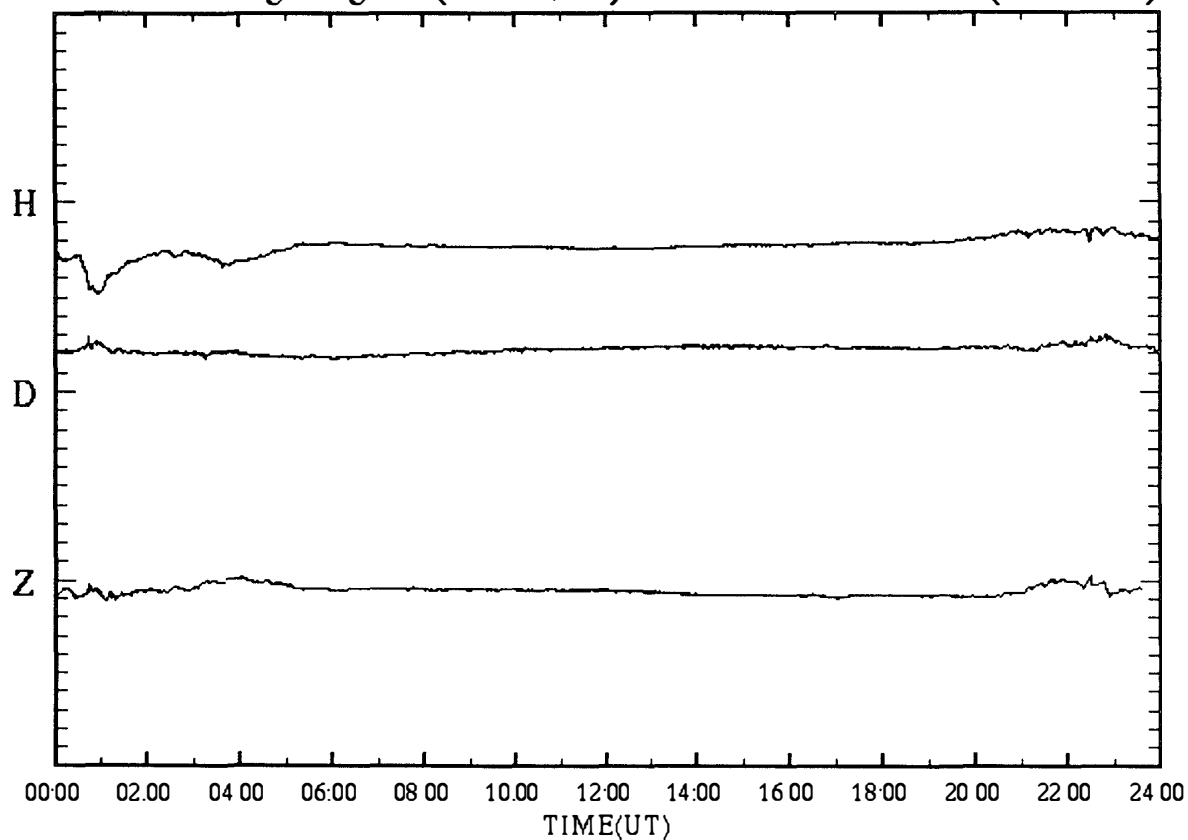

SYOWA magnetogram (100 nT/div)

19 Oct.1997 (DAY:292)

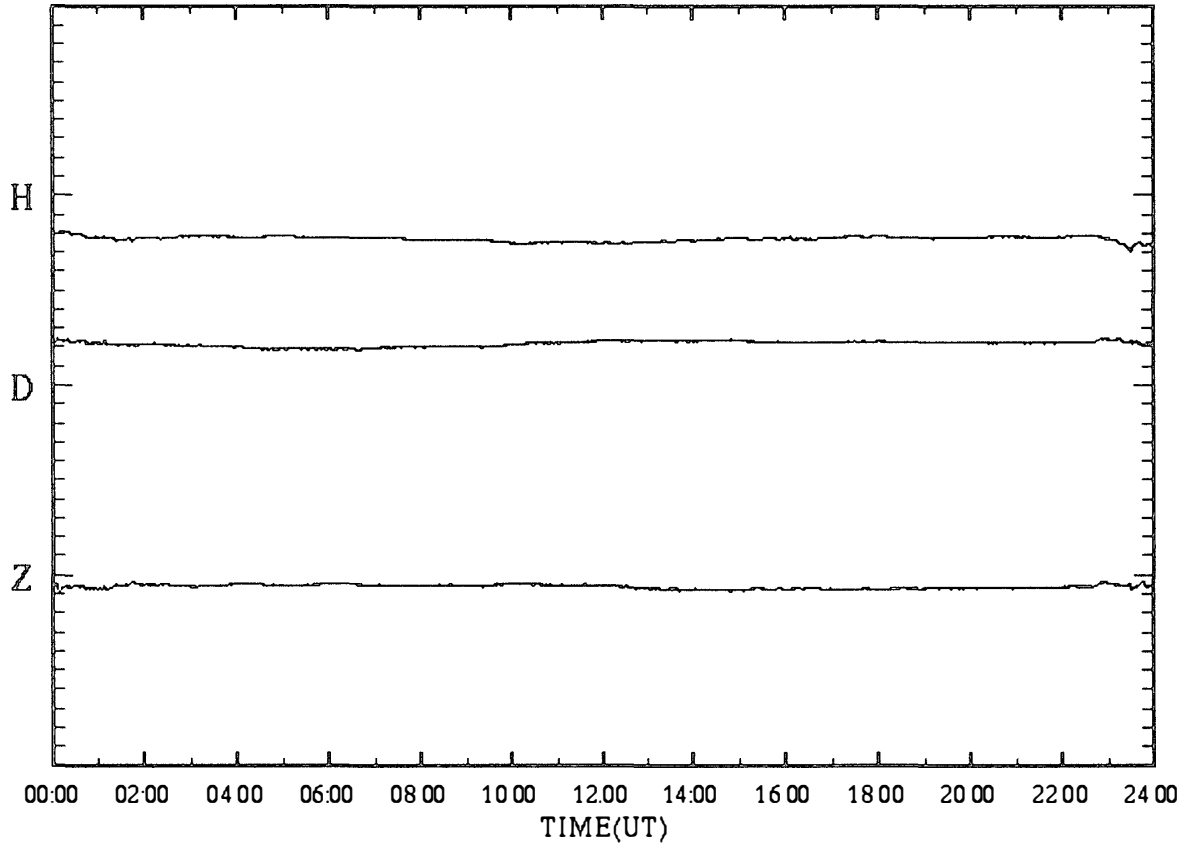

SYOWA magnetogram (100 nT/div)

20 Oct.1997 (DAY:293)

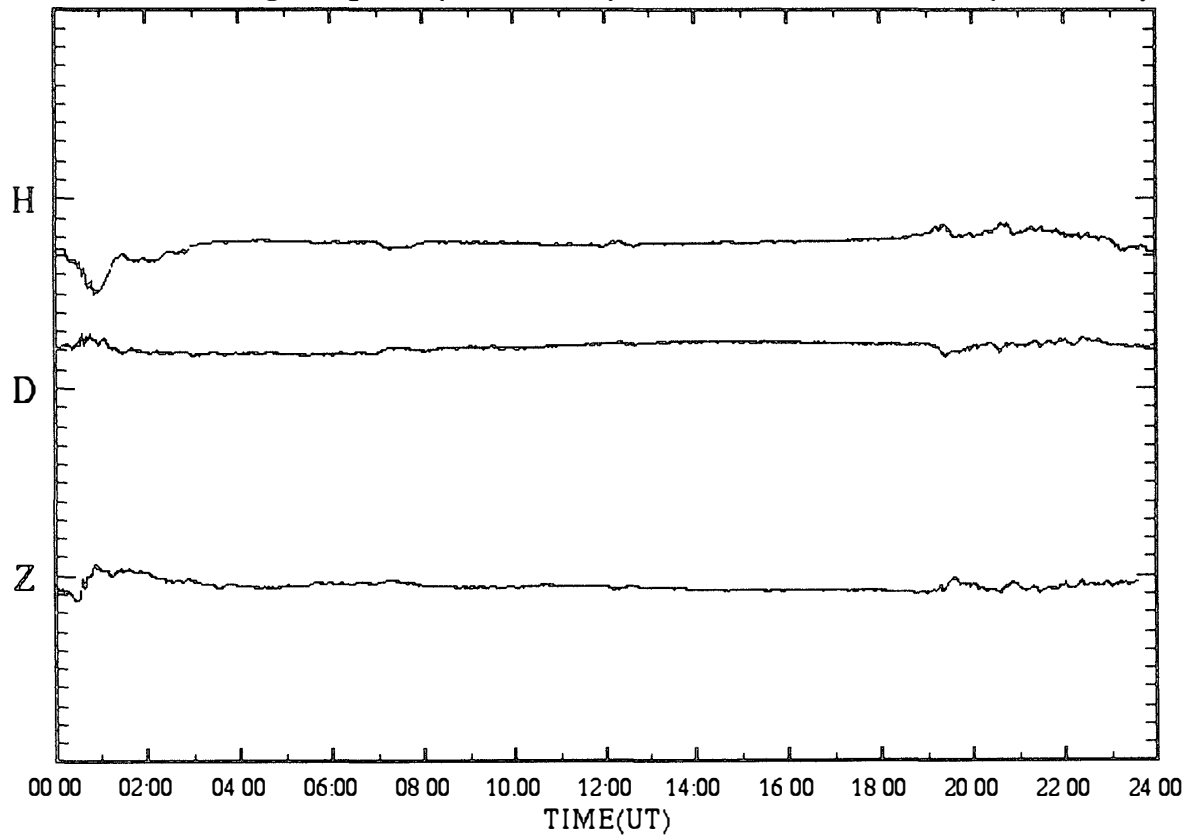



SYOWA magnetogram (100 nT/div)

21 Oct.1997 (DAY:294)

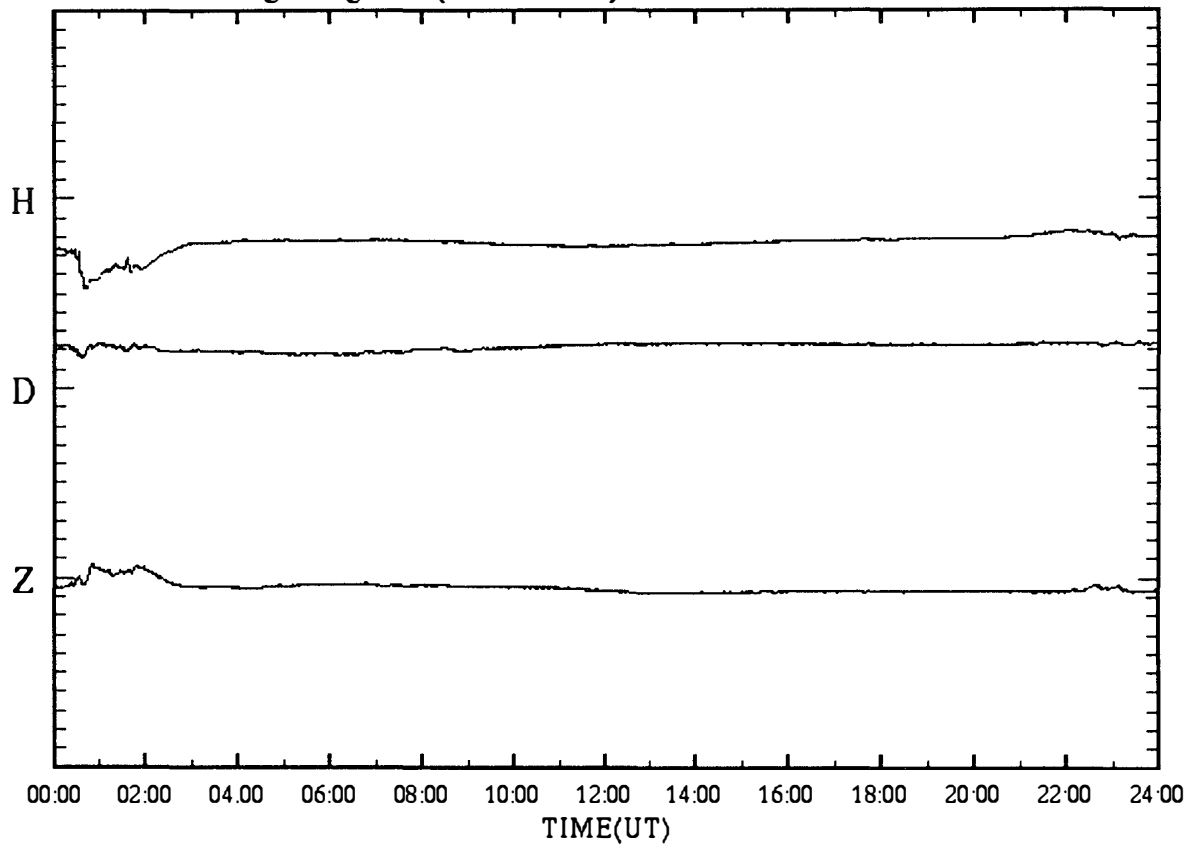

SYOWA magnetogram (100 nT/div)

22 Oct.1997 (DAY:295)

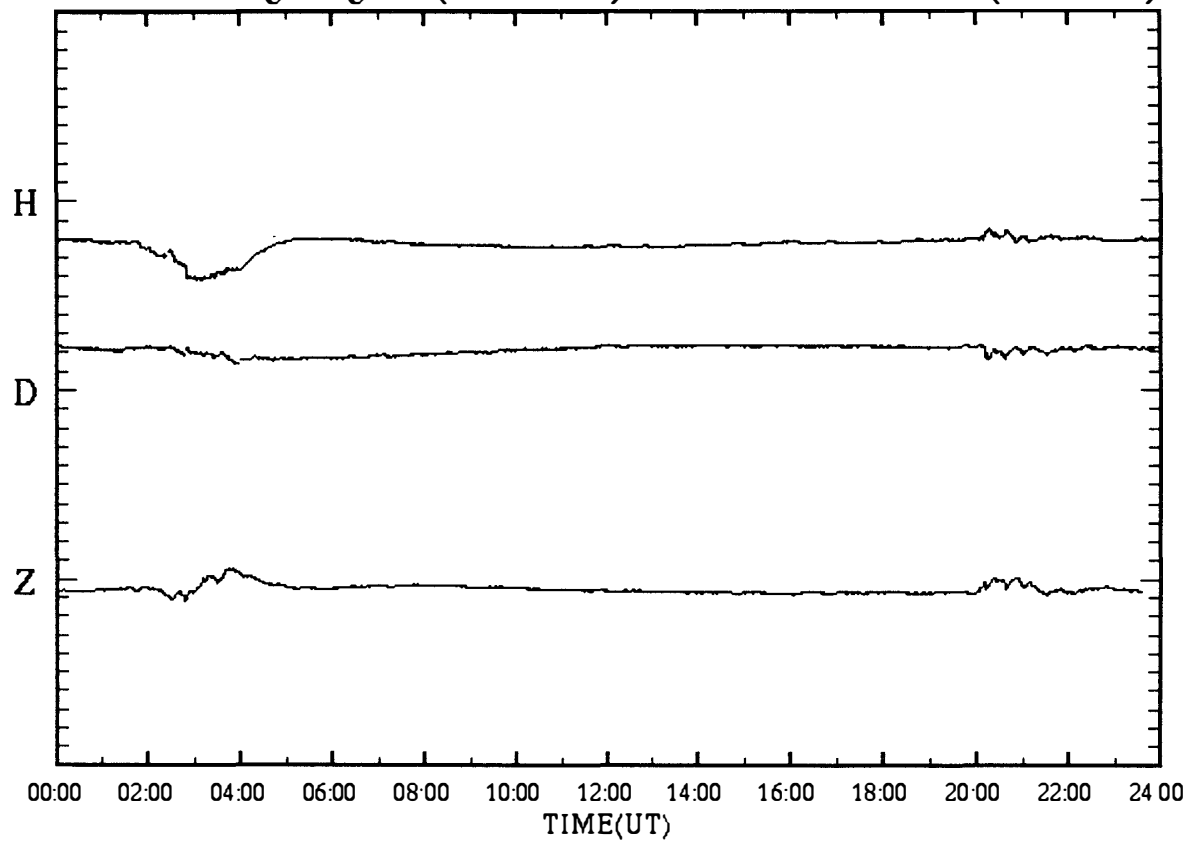

SYOWA magnetogram (100 nT/div)

23 Oct.1997 (DAY:296)

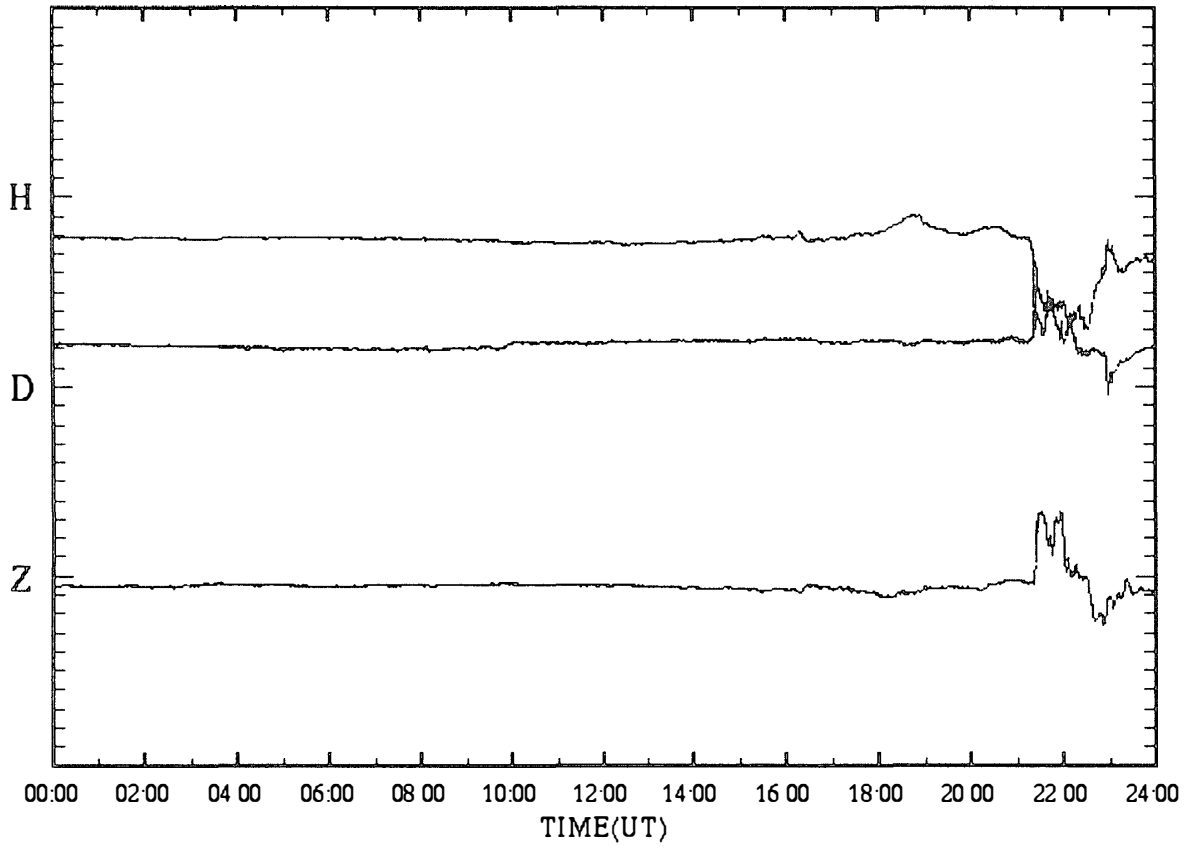

SYOWA magnetogram (100 nT/div)

24 Oct.1997 (DAY:297)

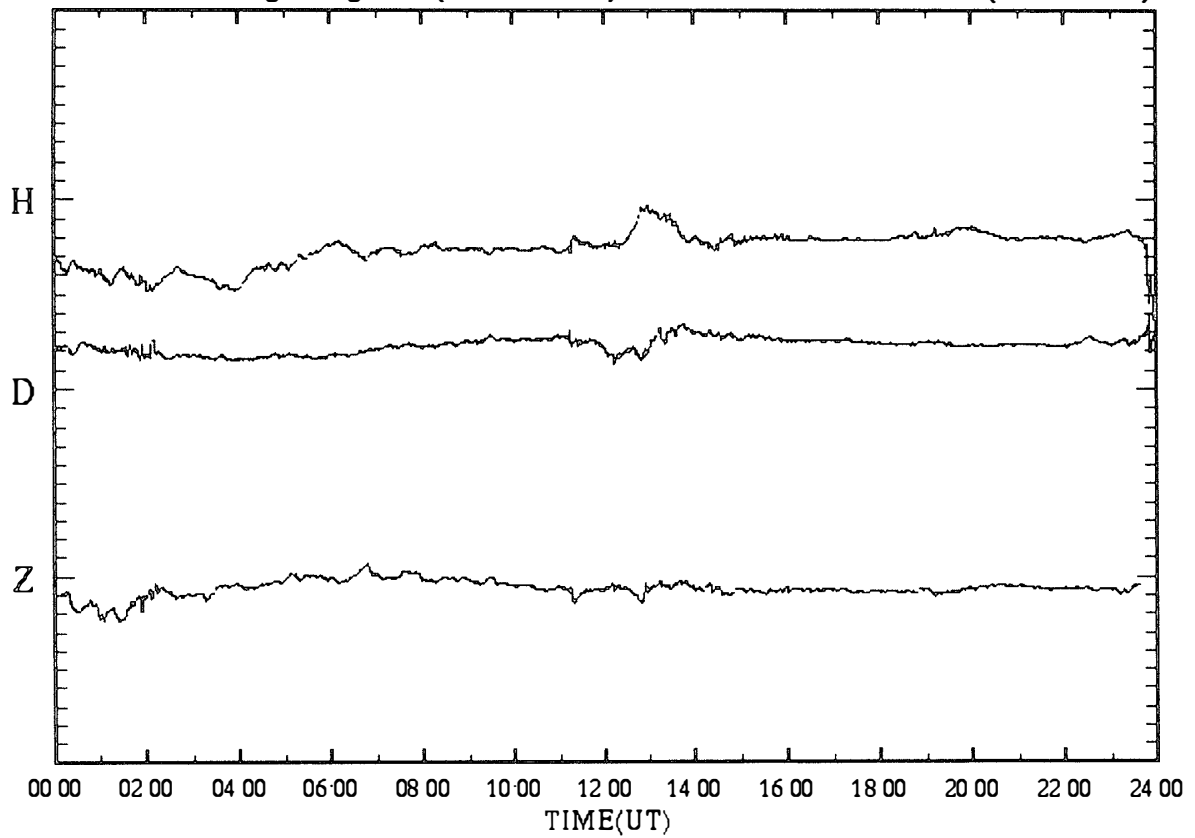

SYOWA magnetogram (100 nT/div)

25 Oct.1997 (DAY:298)

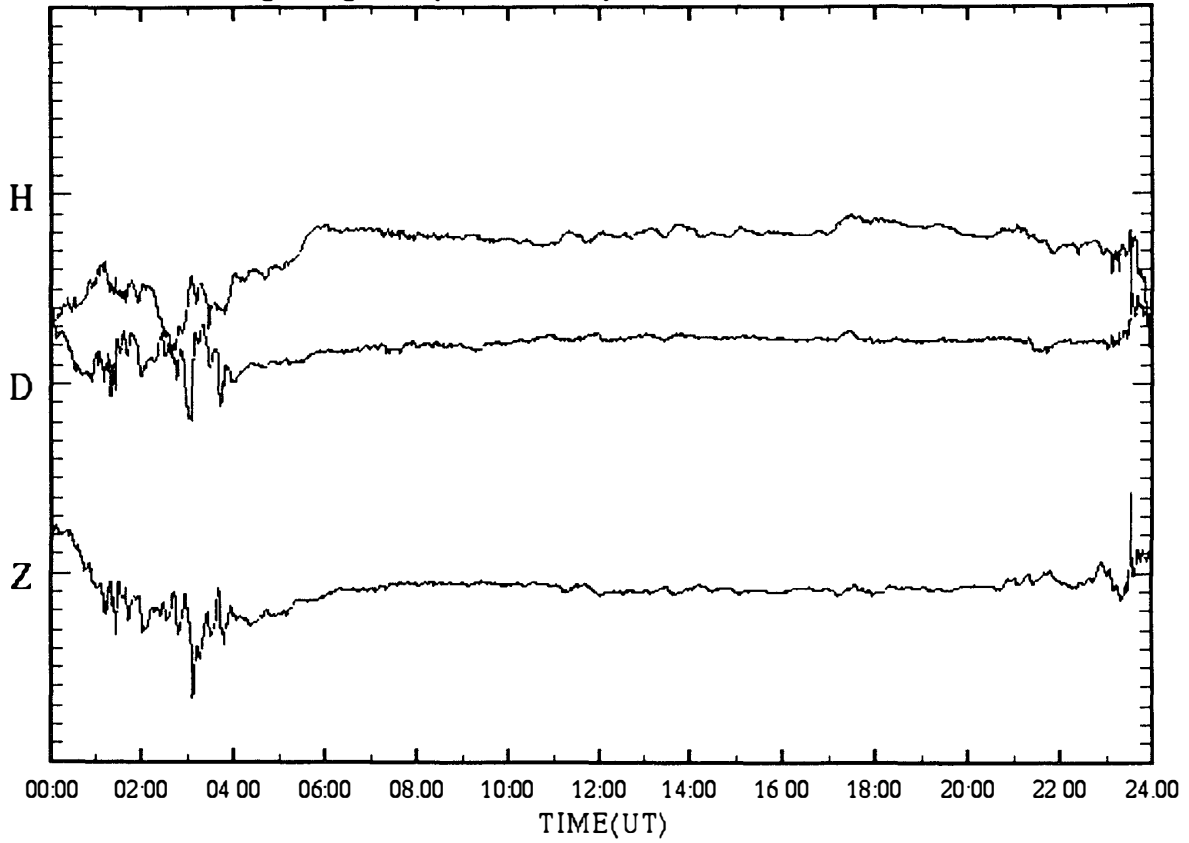

SYOWA magnetogram (100 nT/div)

26 Oct.1997 (DAY:299)

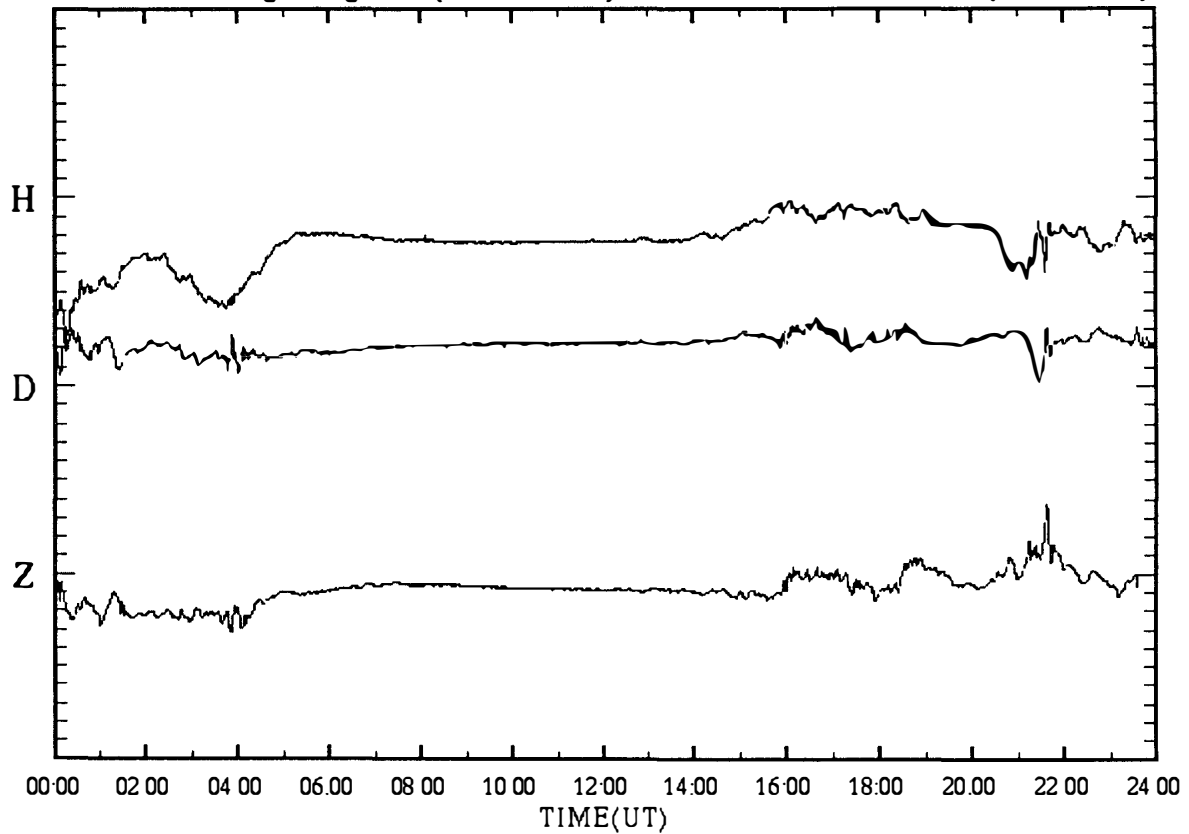

SYOWA magnetogram (100 nT/div)

27 Oct.1997 (DAY:300)

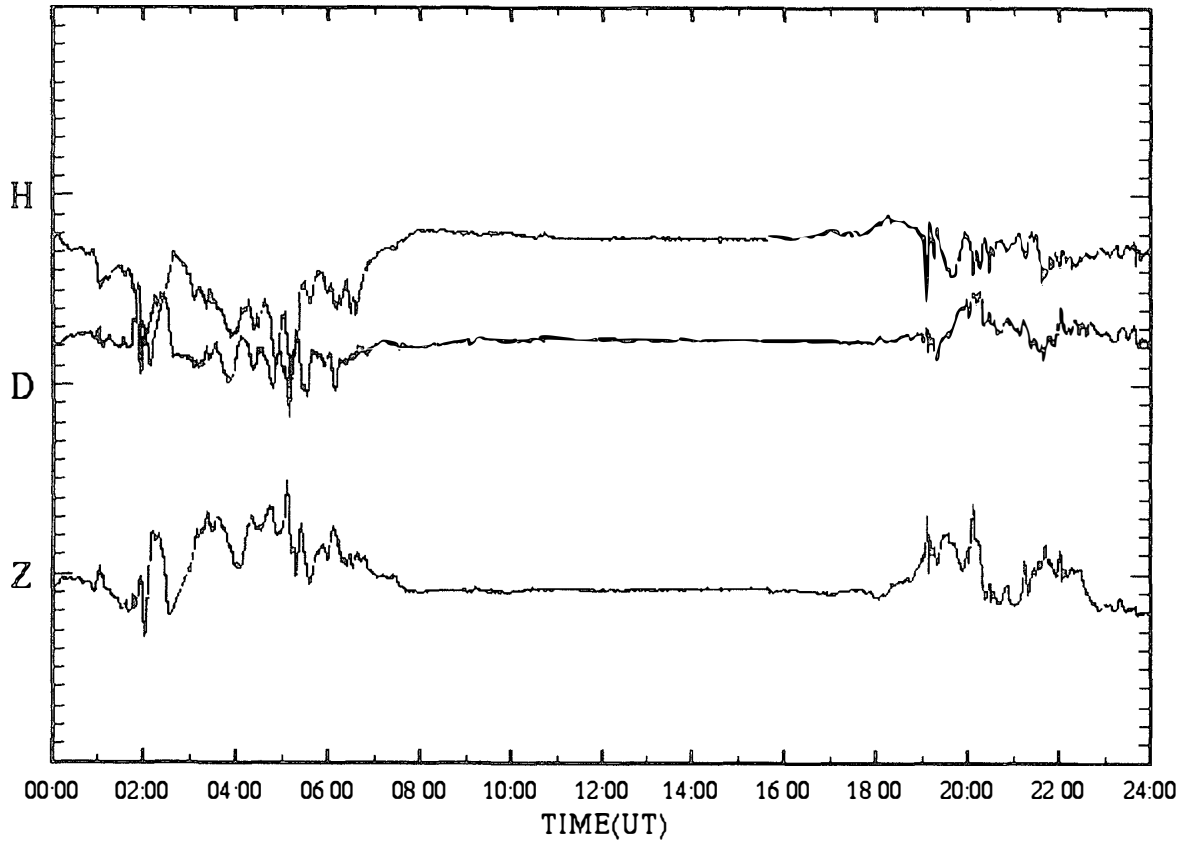

SYOWA magnetogram (100 nT/div)

28 Oct.1997 (DAY:301)

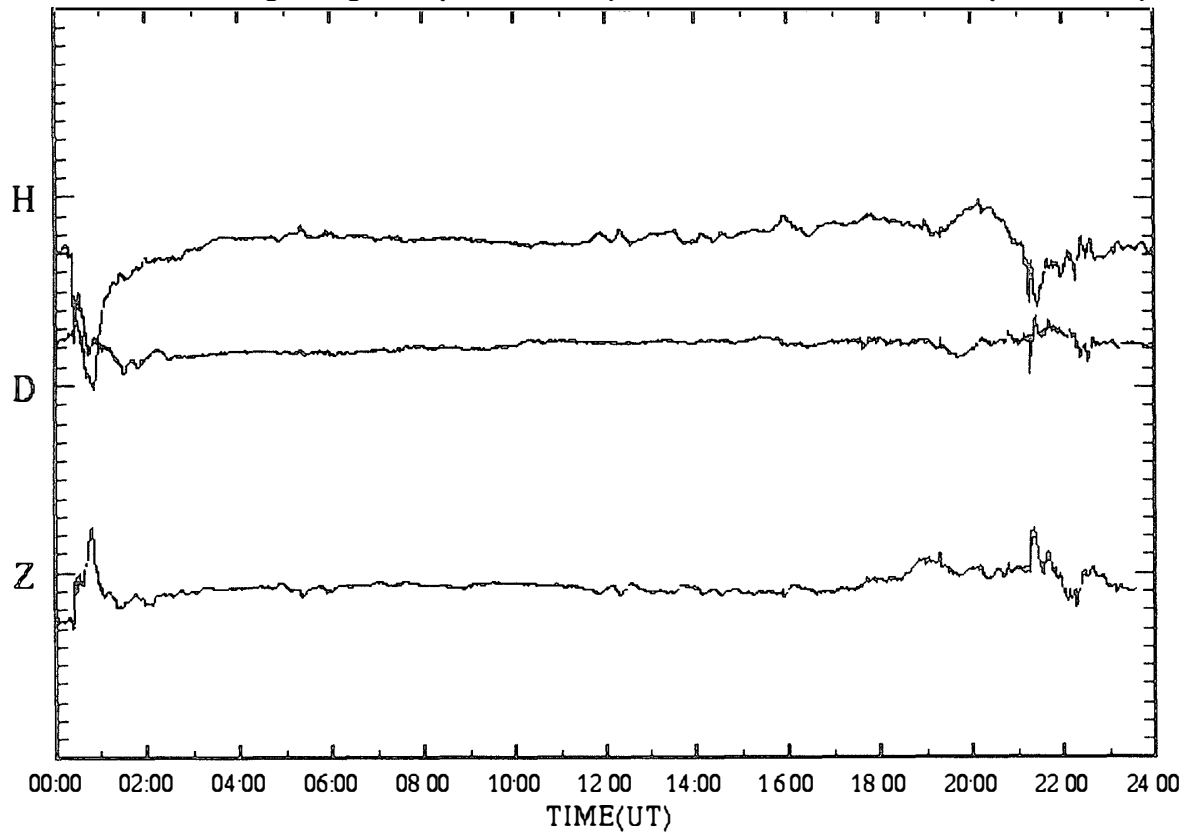

SYOWA magnetogram (100 nT/div)

29 Oct.1997 (DAY:302)

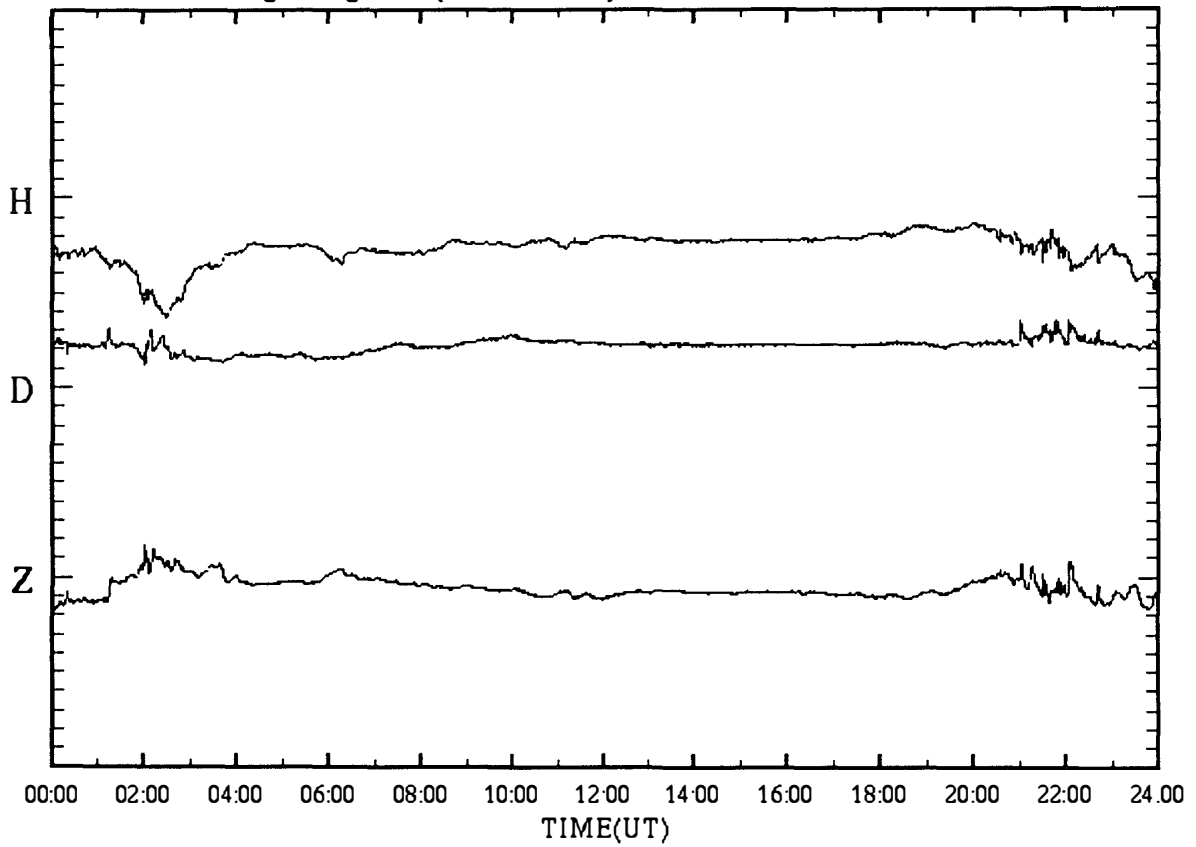

SYOWA magnetogram (100 nT/div)

30 Oct.1997 (DAY:303)

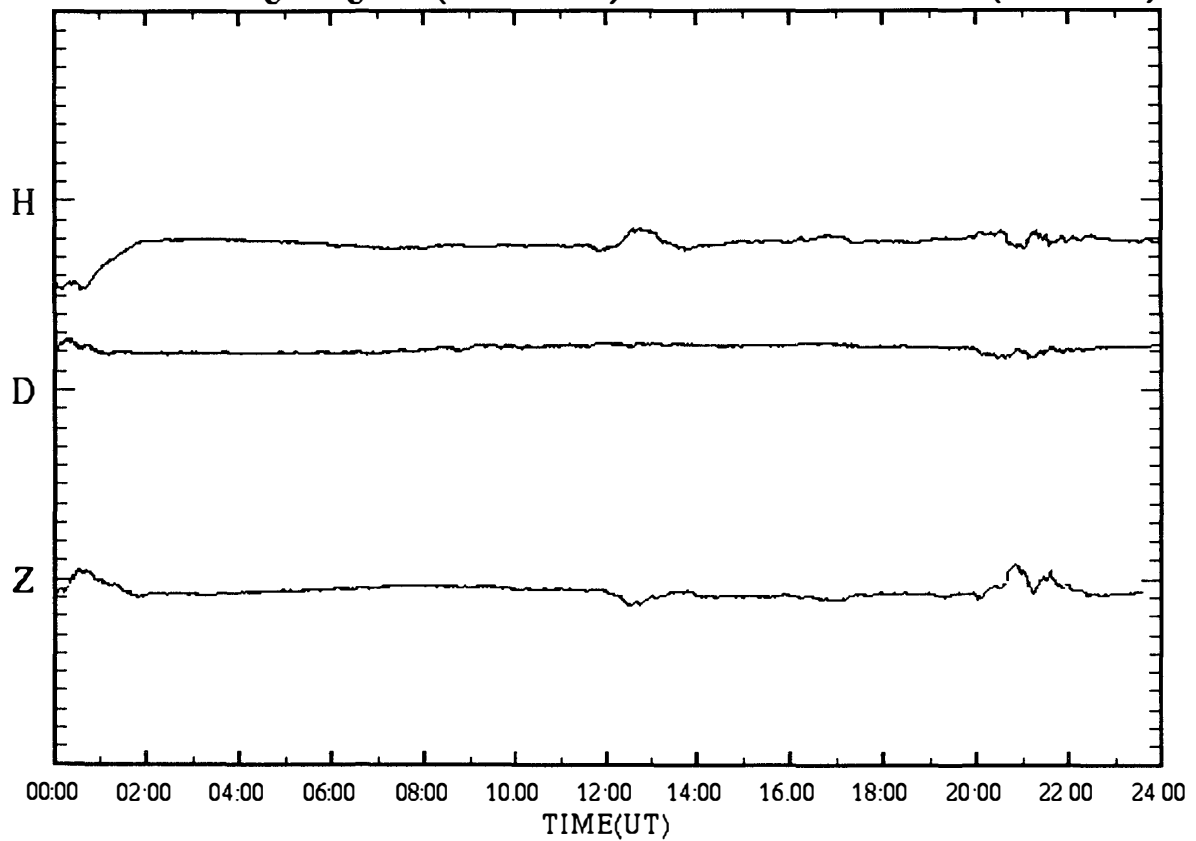

SYOWA magnetogram (100 nT/div)

31 Oct.1997 (DAY:304)

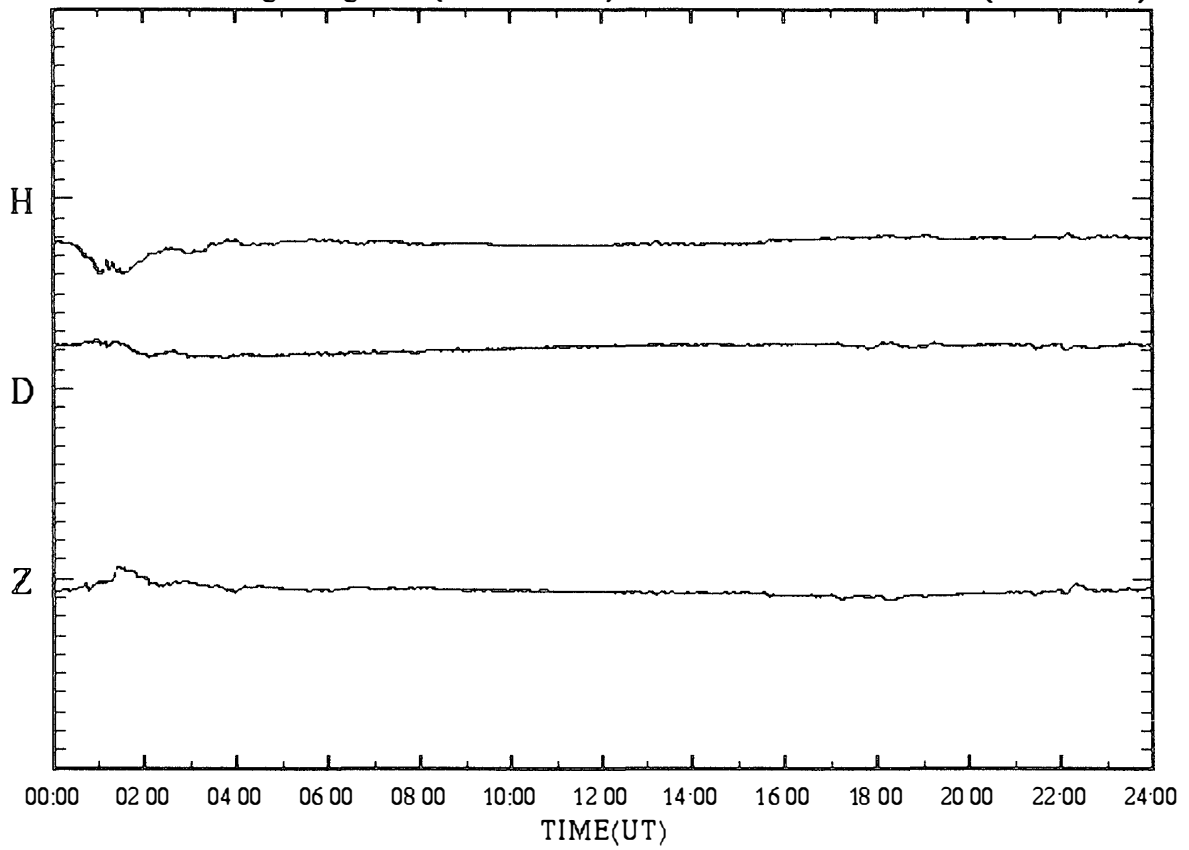

SYOWA magnetogram (100 nT/div)

01 Nov.1997 (DAY:305)

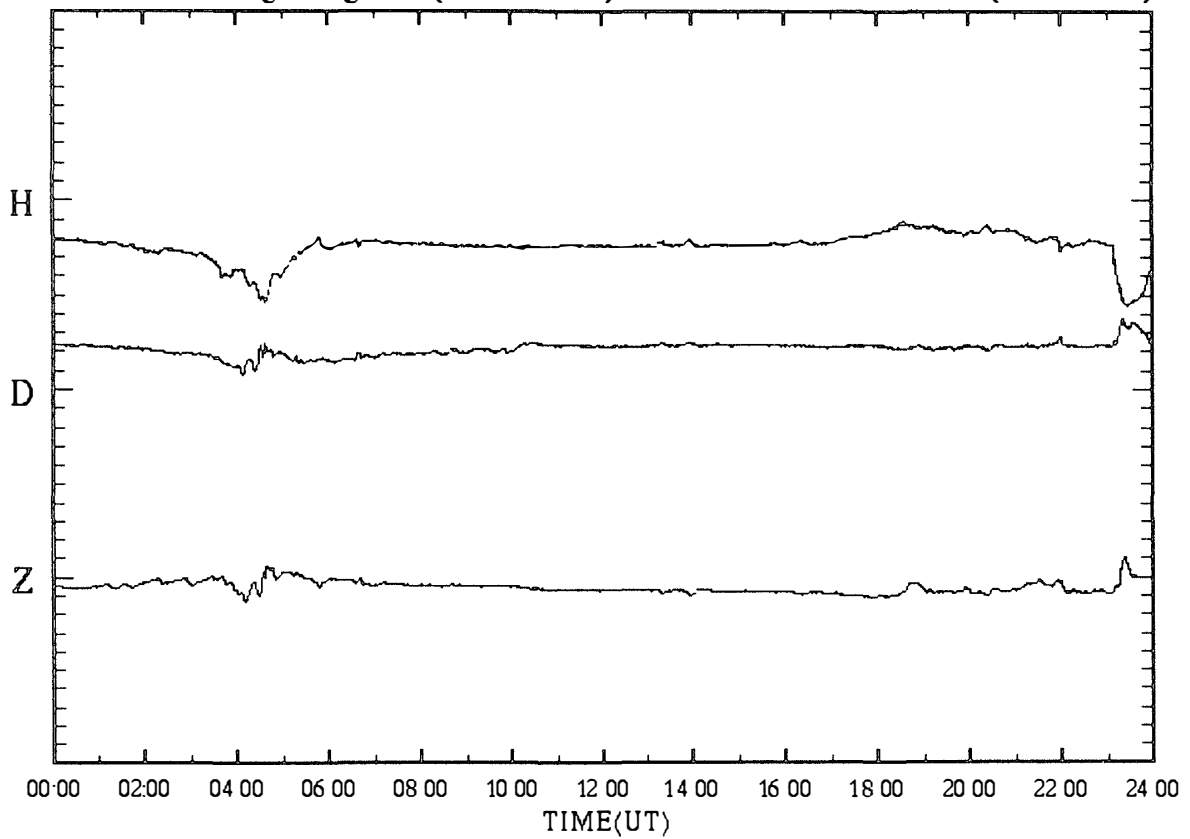

SYOWA magnetogram (100 nT/div)

02 Nov.1997 (DAY:306)

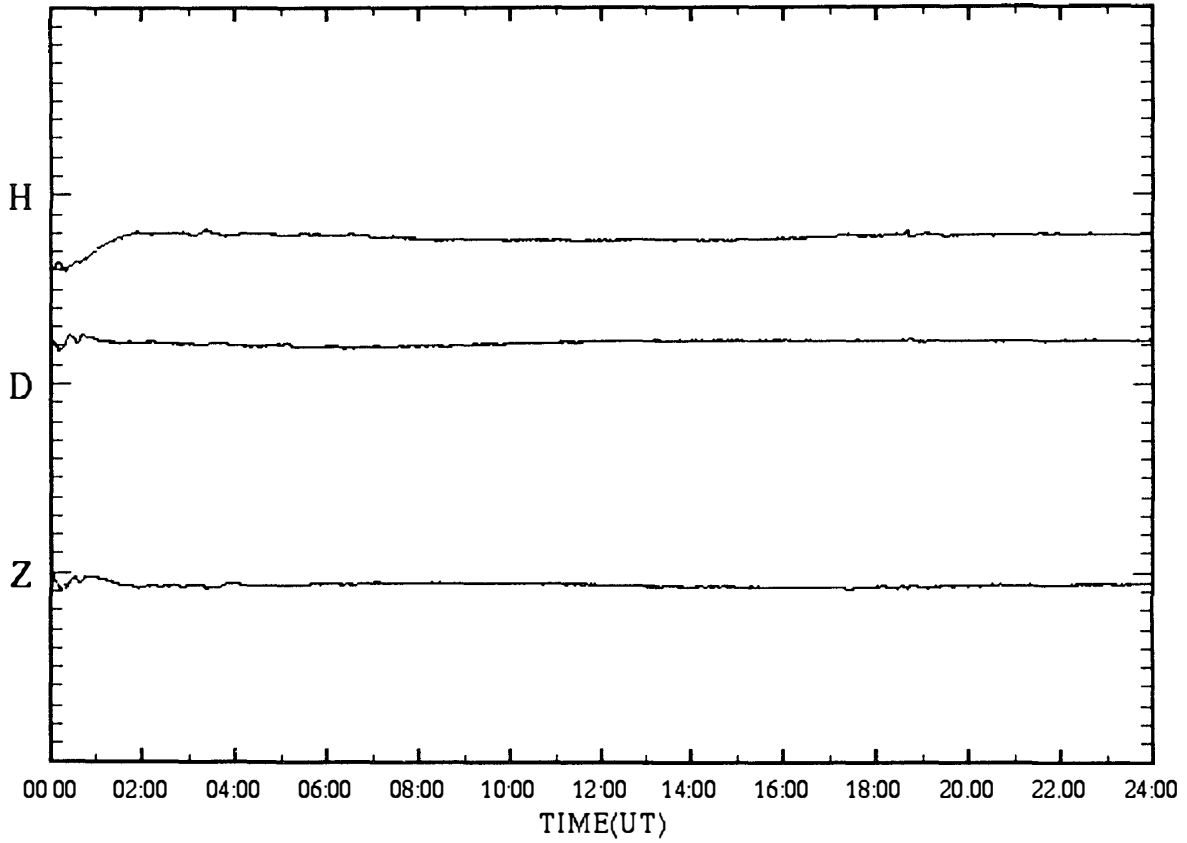

SYOWA magnetogram (100 nT/div)

03 Nov.1997 (DAY:307)

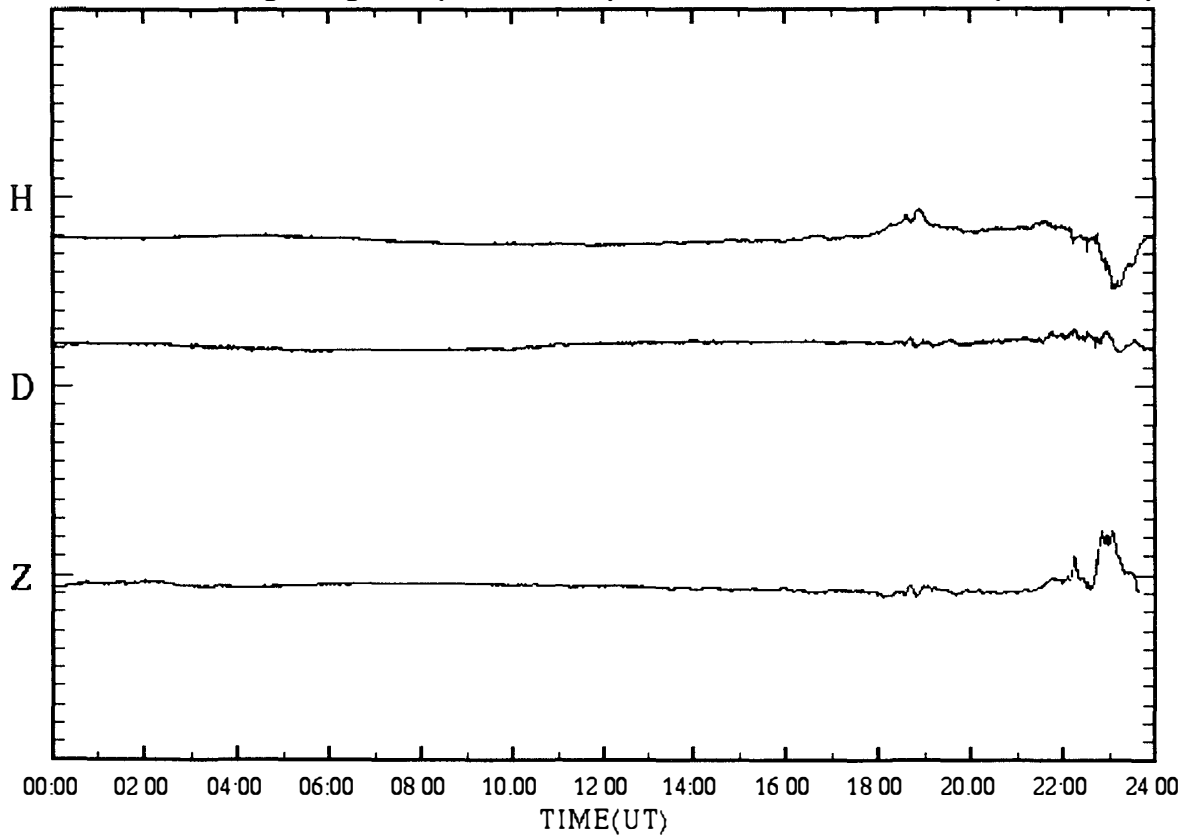

SYOWA magnetogram (100 nT/div)

04 Nov.1997 (DAY:308)

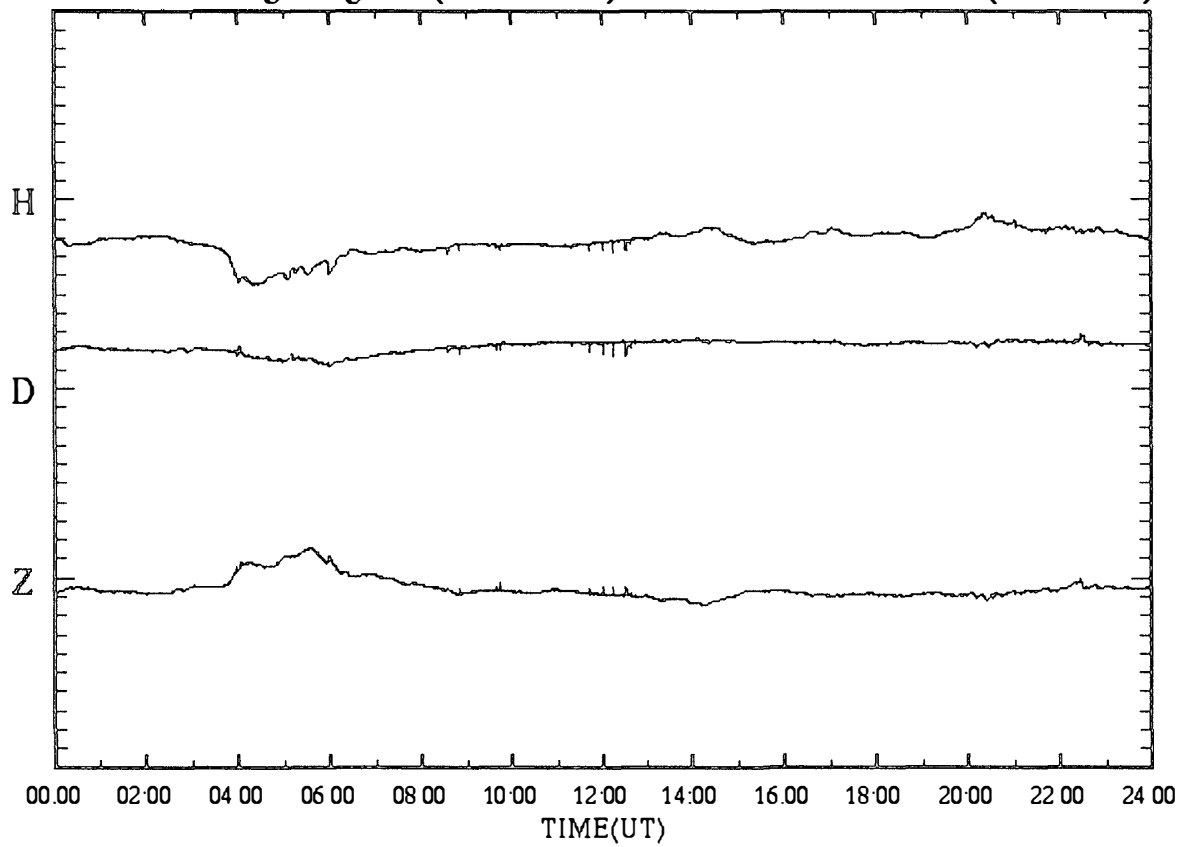

SYOWA magnetogram (100 nT/div)

05 Nov.1997 (DAY:309)

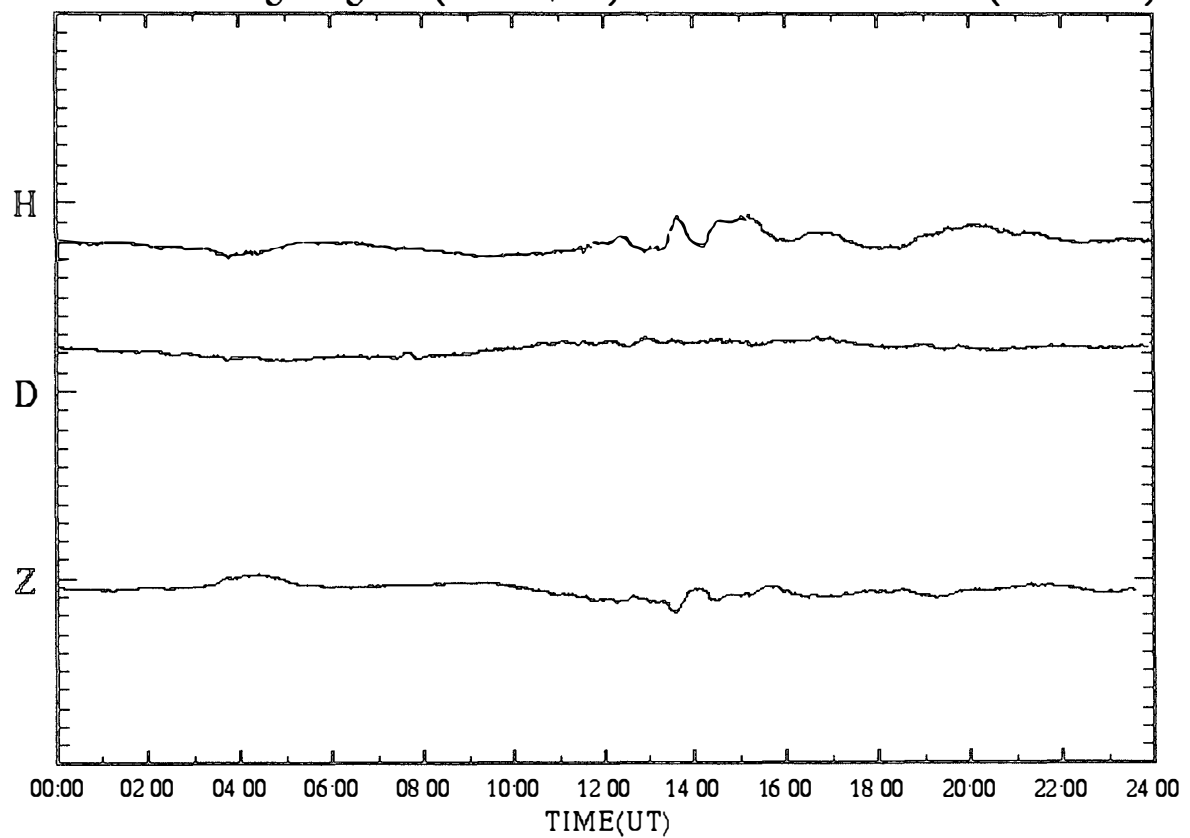



SYOWA magnetogram (100 nT/div)

06 Nov.1997 (DAY:310)

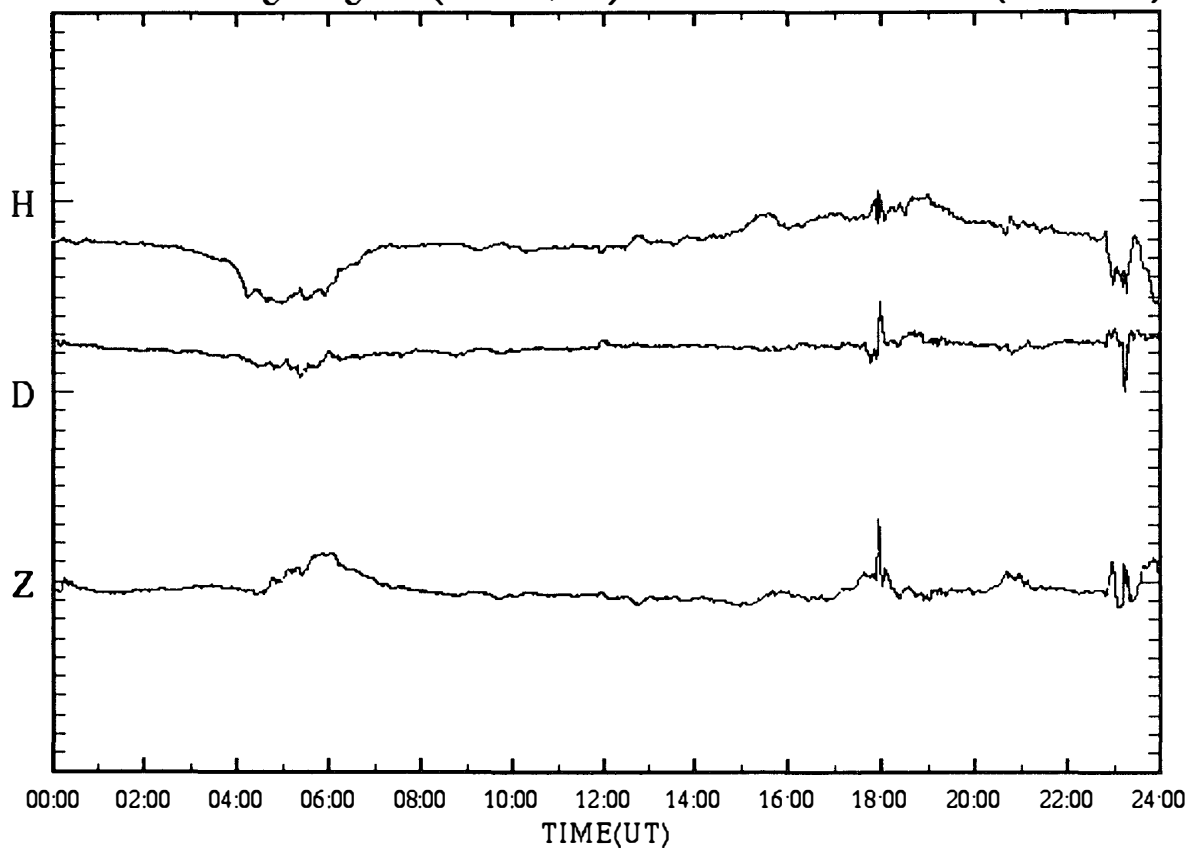

SYOWA magnetogram (100 nT/div)

07 Nov.1997 (DAY:311)

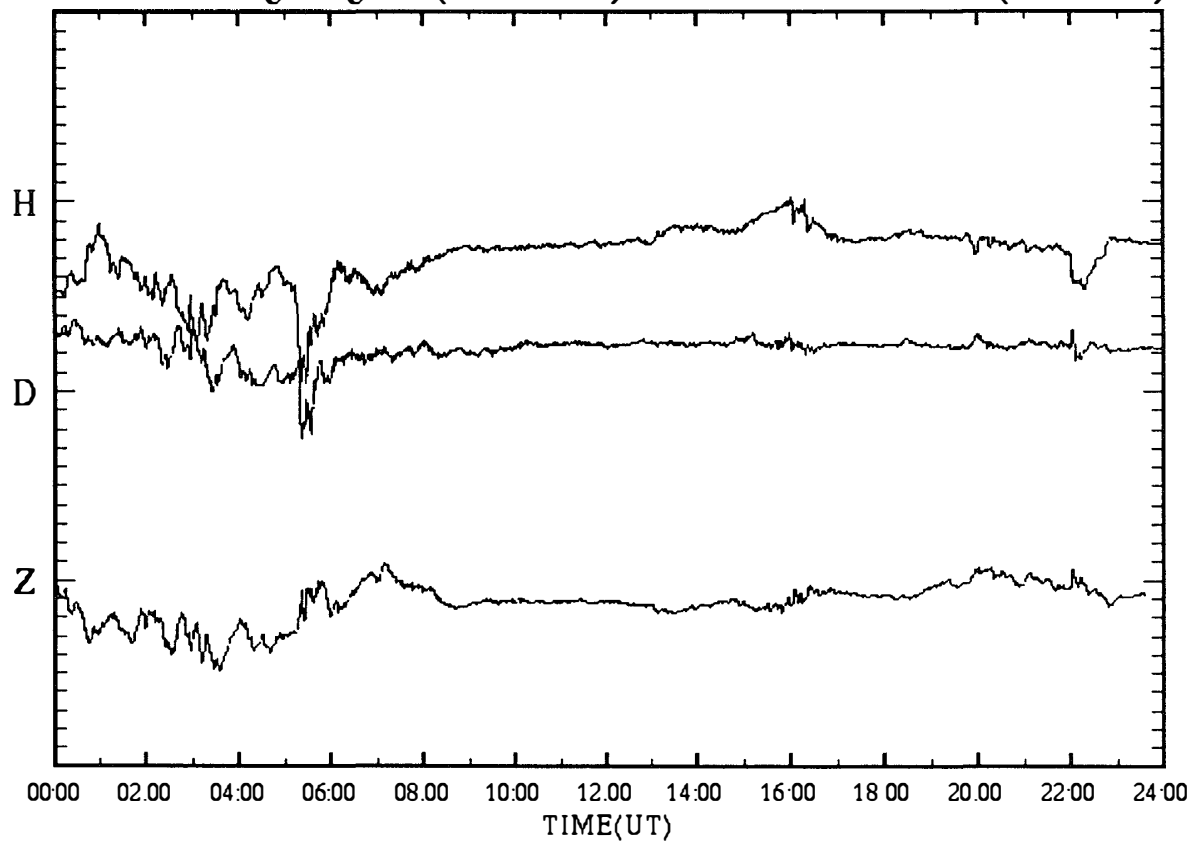

SYOWA magnetogram (100 nT/div)

08 Nov.1997 (DAY:312)

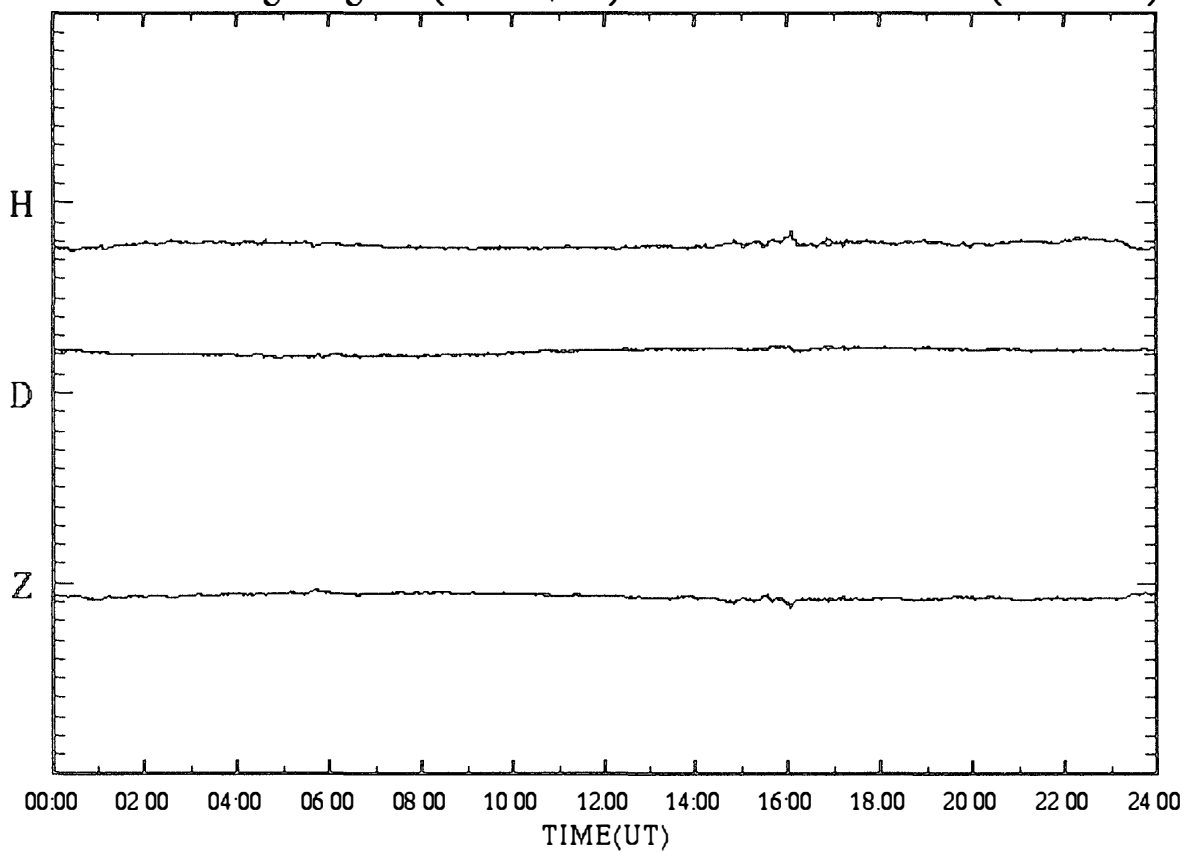

SYOWA magnetogram (100 nT/div)

09 Nov.1997 (DAY:313)

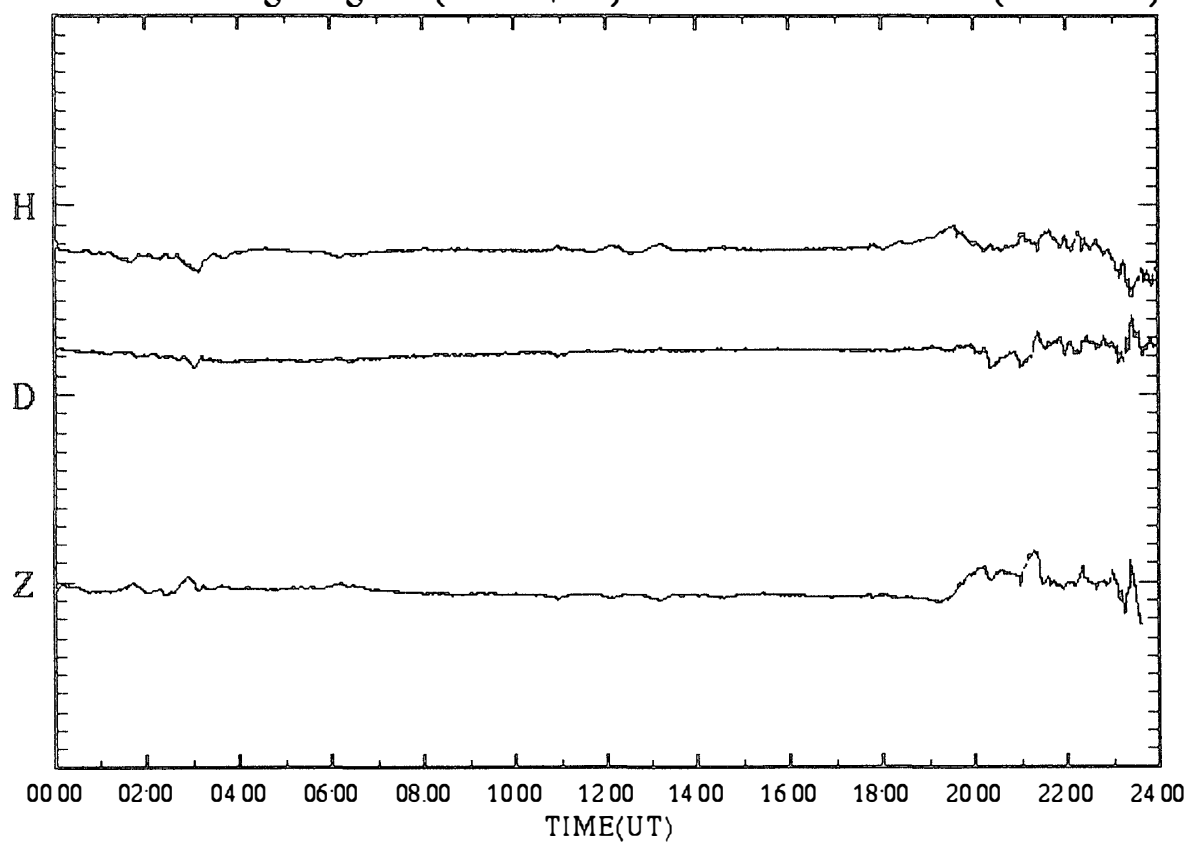

SYOWA magnetogram (100 nT/div)

10 Nov.1997 (DAY:314)

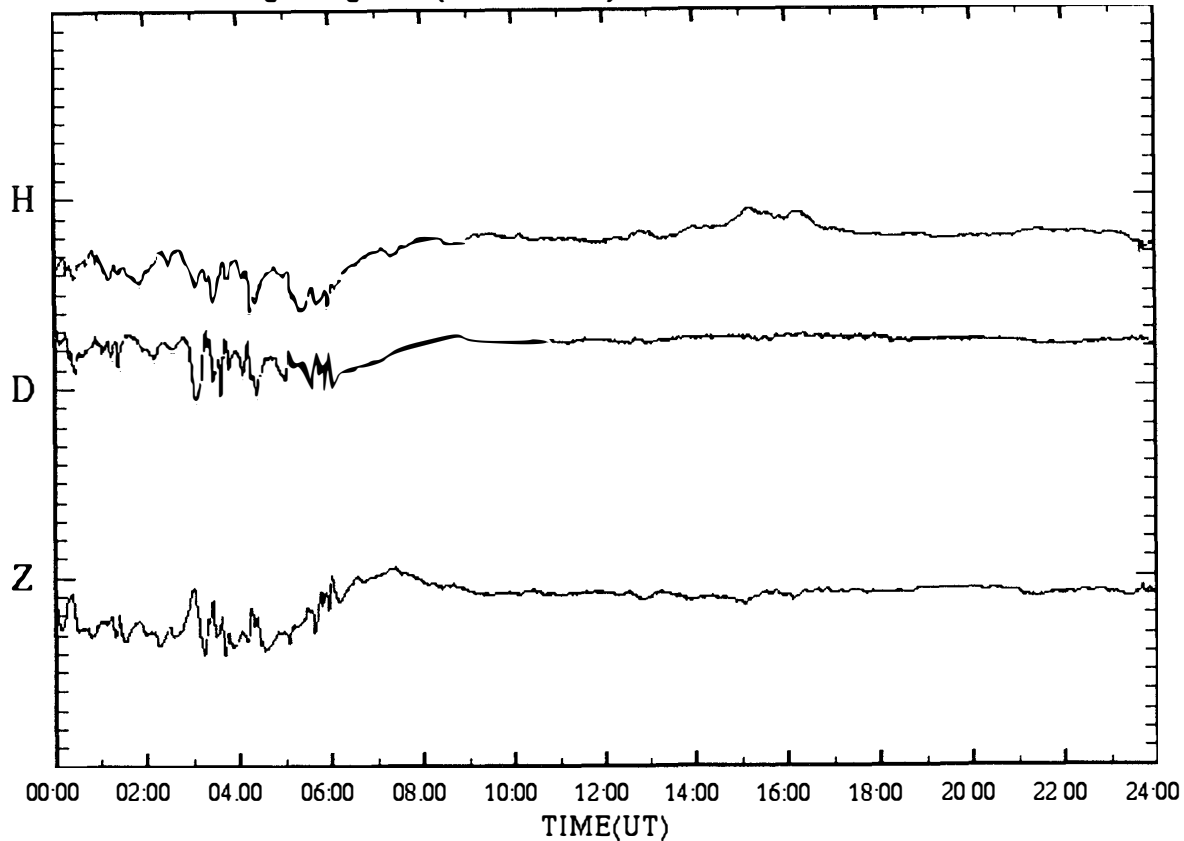

SYOWA magnetogram (100 nT/div)

11 Nov.1997 (DAY:315)

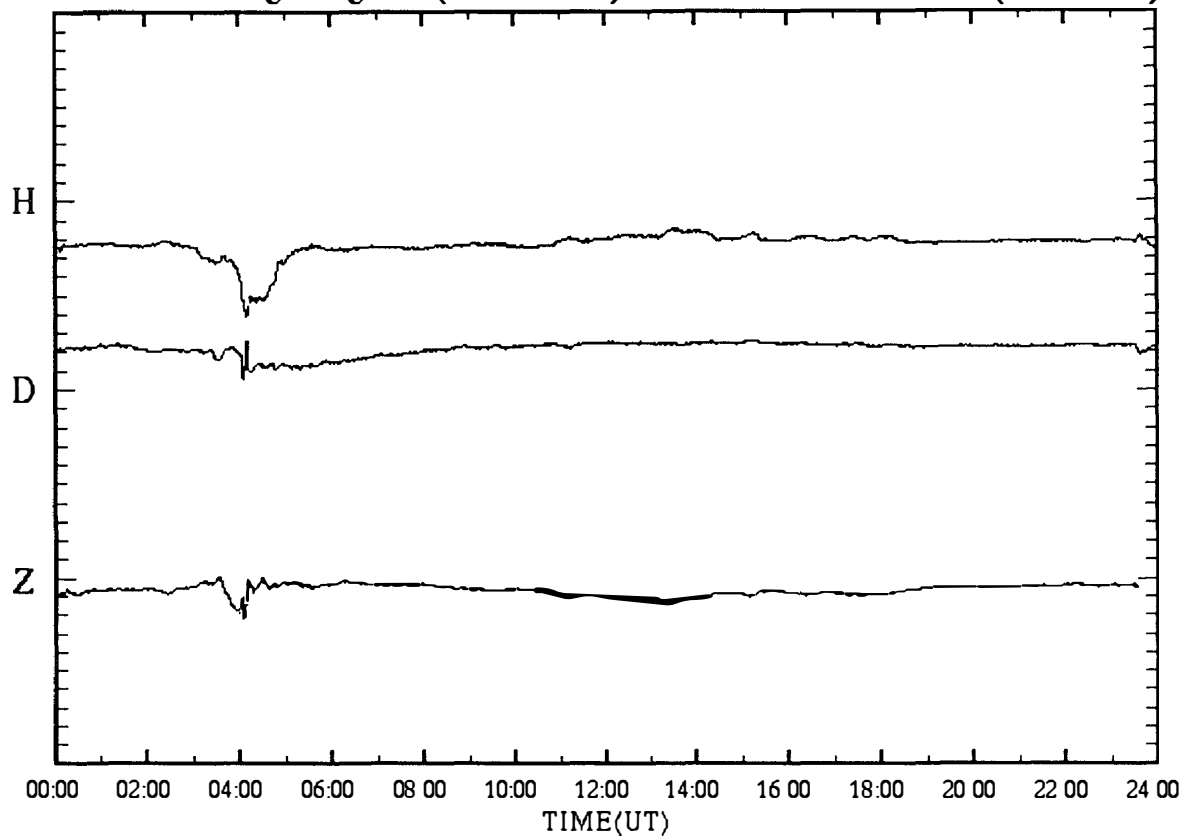

SYOWA magnetogram (100 nT/div)

12 Nov.1997 (DAY:316)

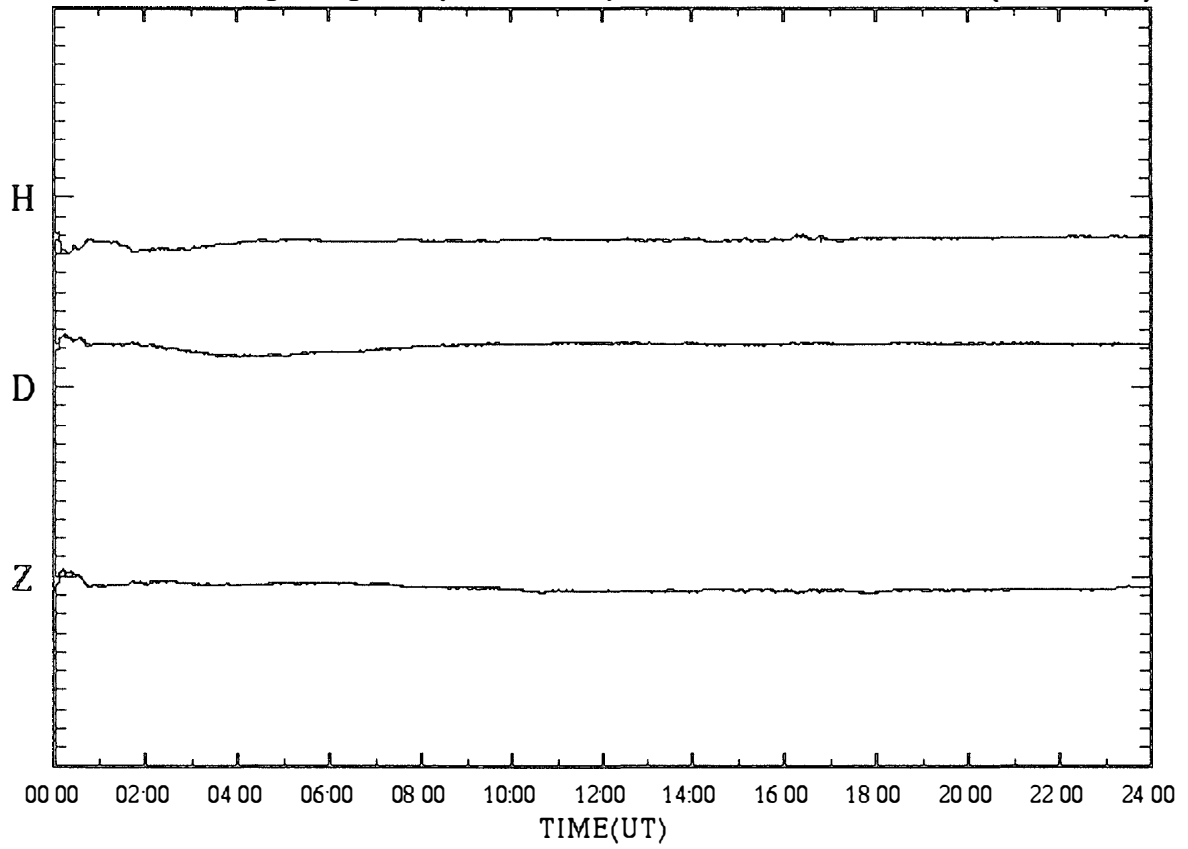

SYOWA magnetogram (100 nT/div)

13 Nov.1997 (DAY:317)

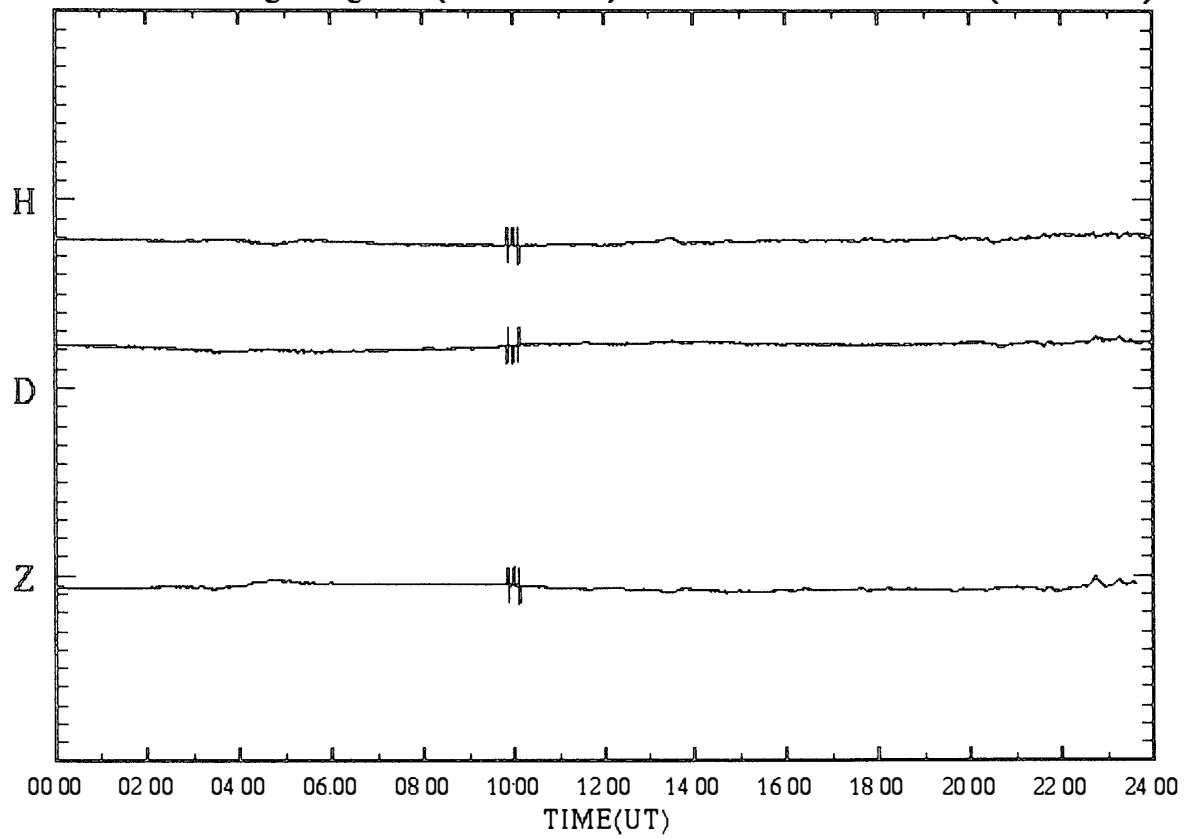

SYOWA magnetogram (100 nT/div)

14 Nov.1997 (DAY:318)

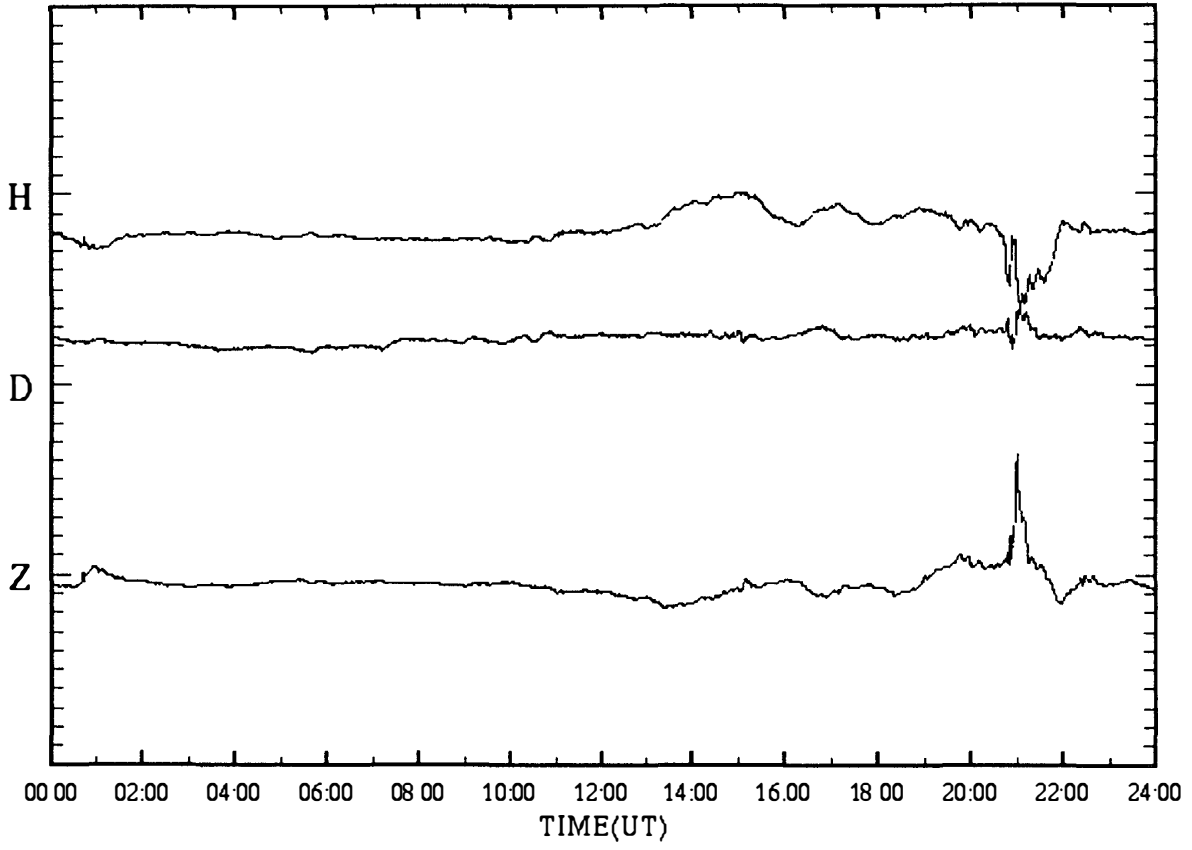

SYOWA magnetogram (100 nT/div)

15 Nov.1997 (DAY:319)

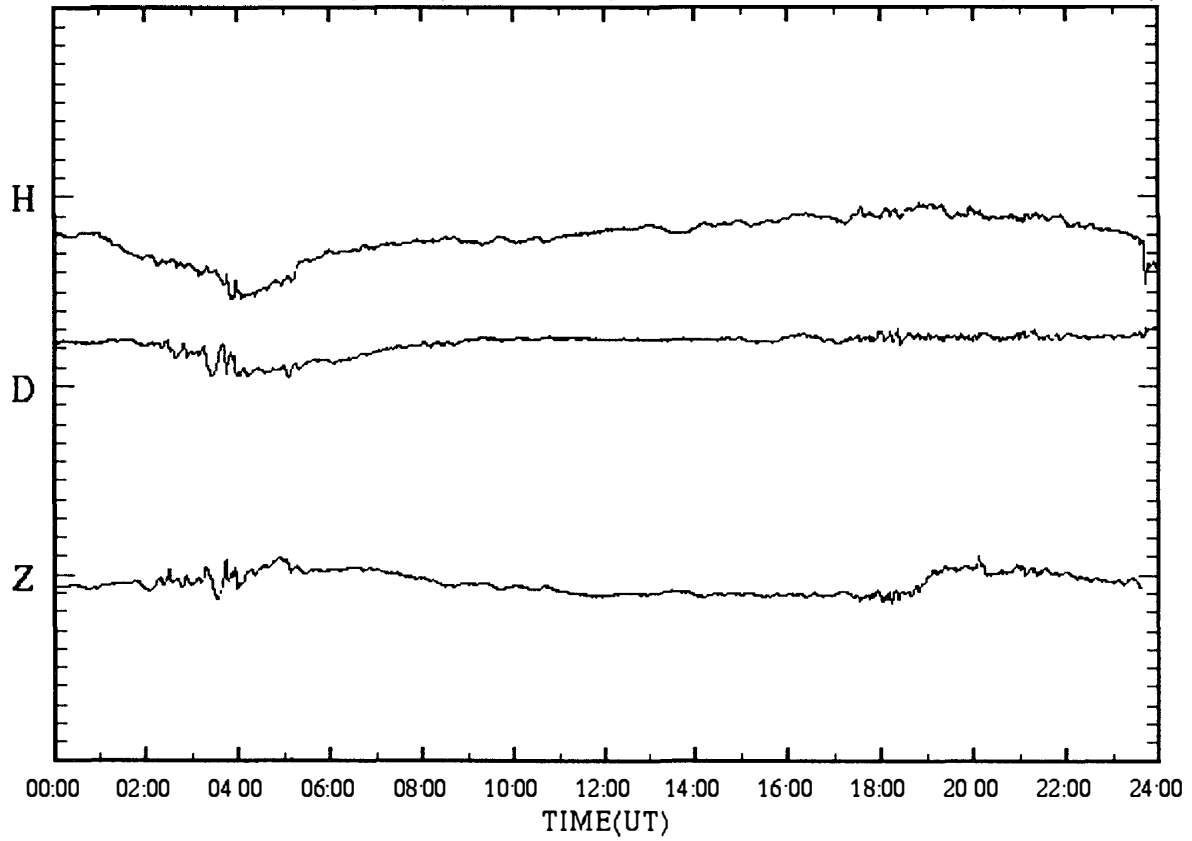

SYOWA magnetogram (100 nT/div)

16 Nov.1997 (DAY:320)

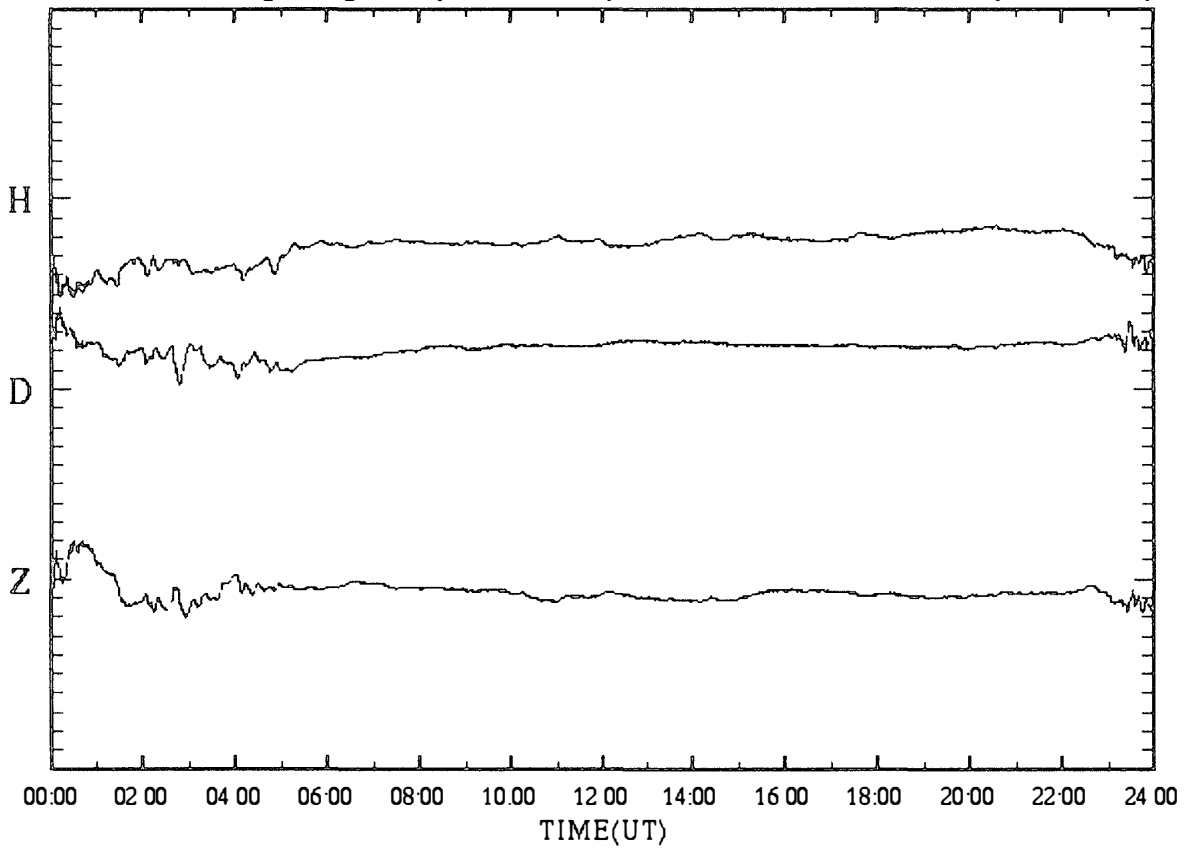

SYOWA magnetogram (100 nT/div)

17 Nov.1997 (DAY:321)

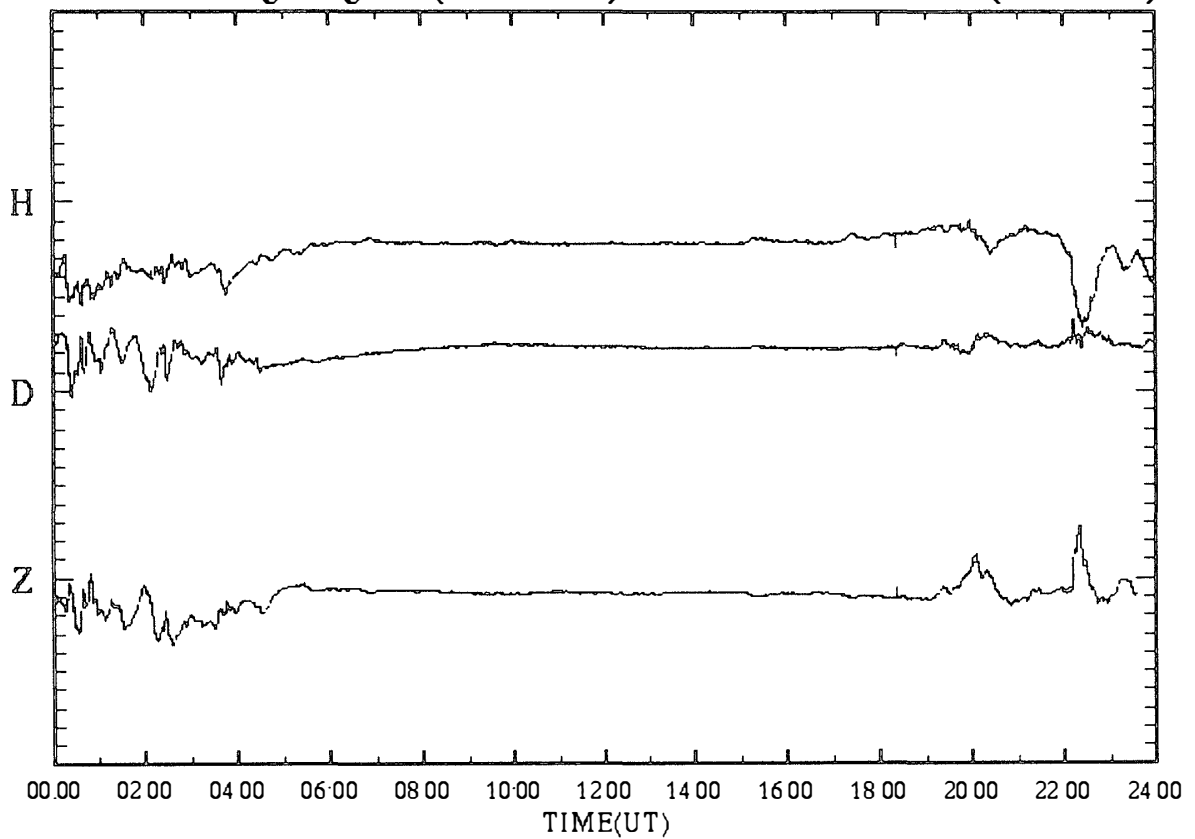

SYOWA magnetogram (100 nT/div) 18 Nov.1997 (DAY:322)

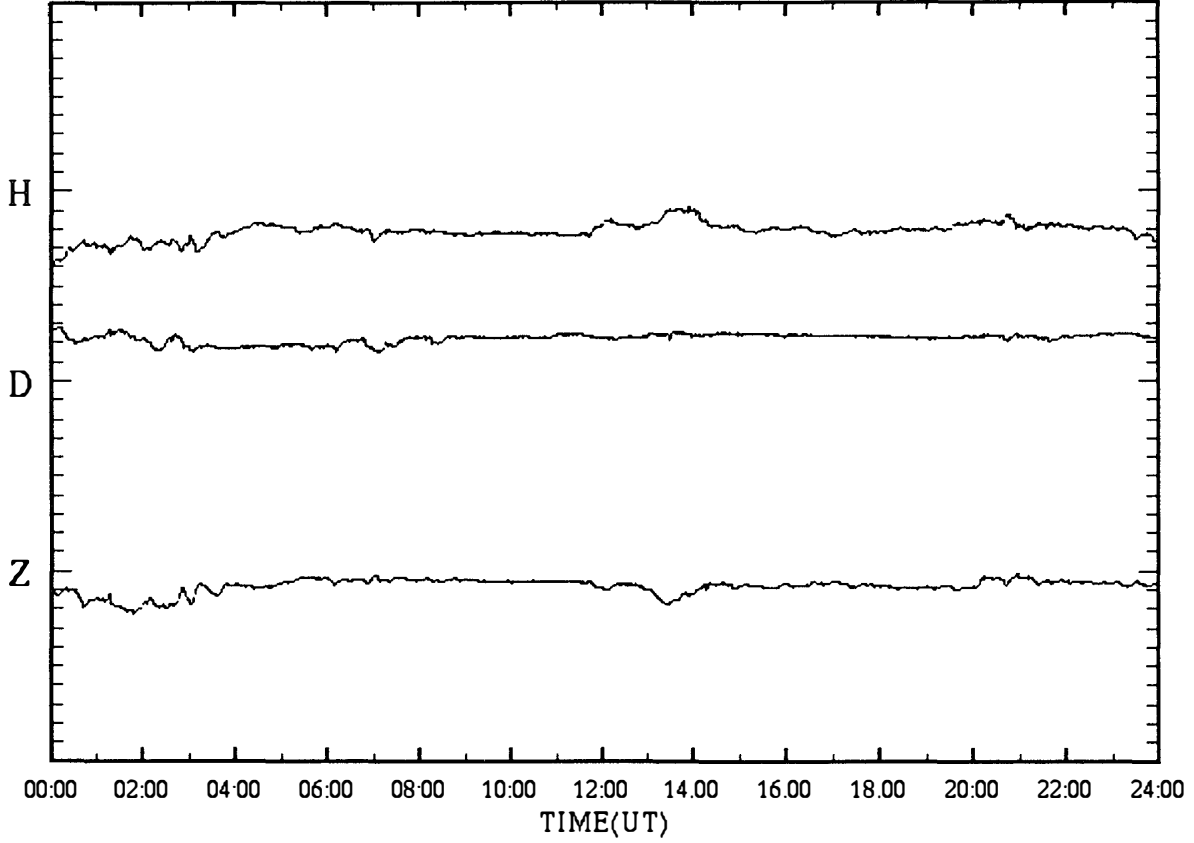

SYOWA magnetogram (100 nT/div) 19 Nov.1997 (DAY:323)

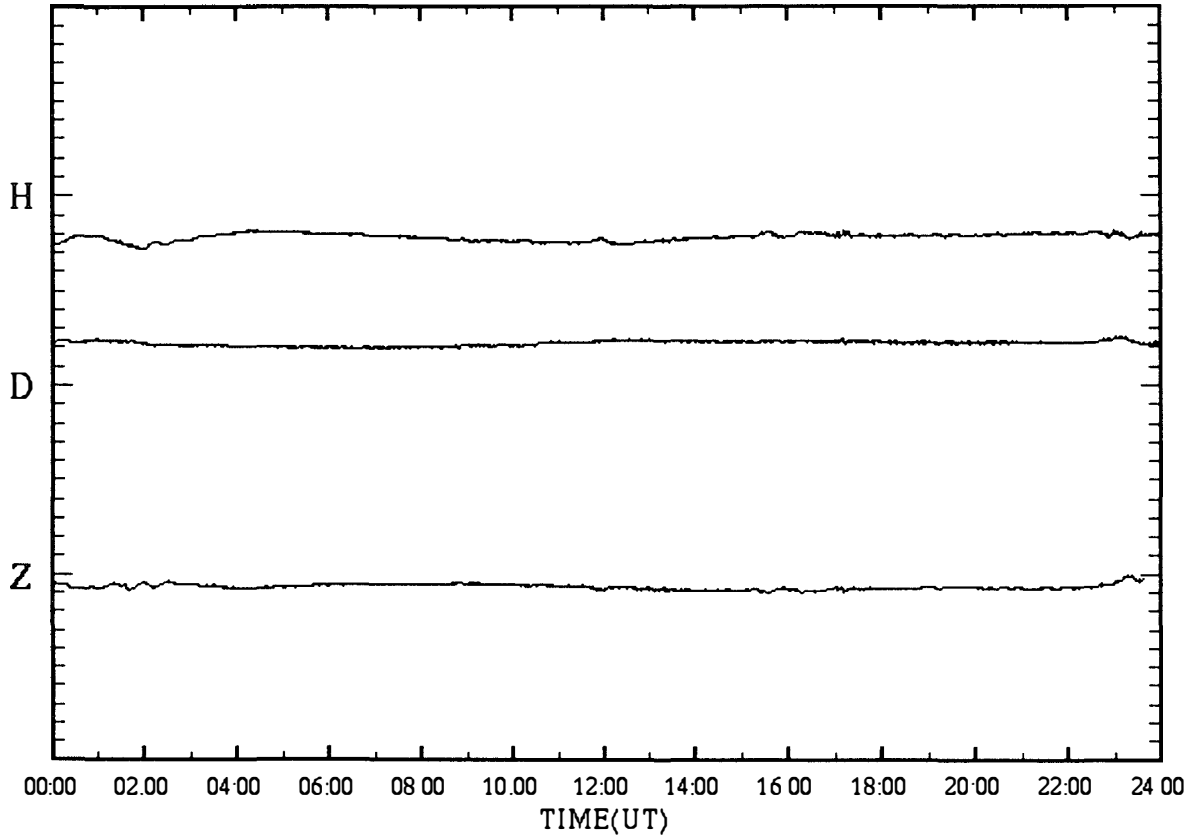

SYOWA magnetogram (100 nT/div)

20 Nov.1997 (DAY:324)

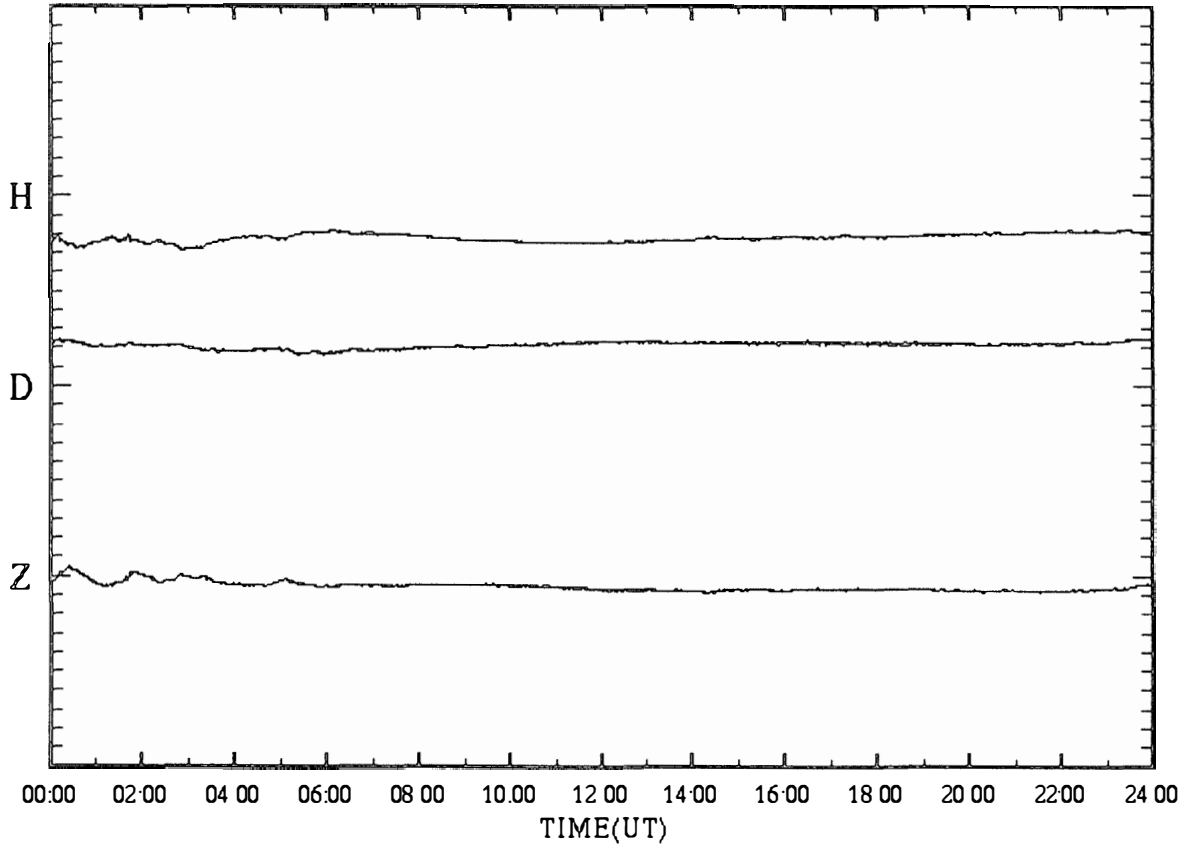

SYOWA magnetogram (100 nT/div)

21 Nov.1997 (DAY:325)

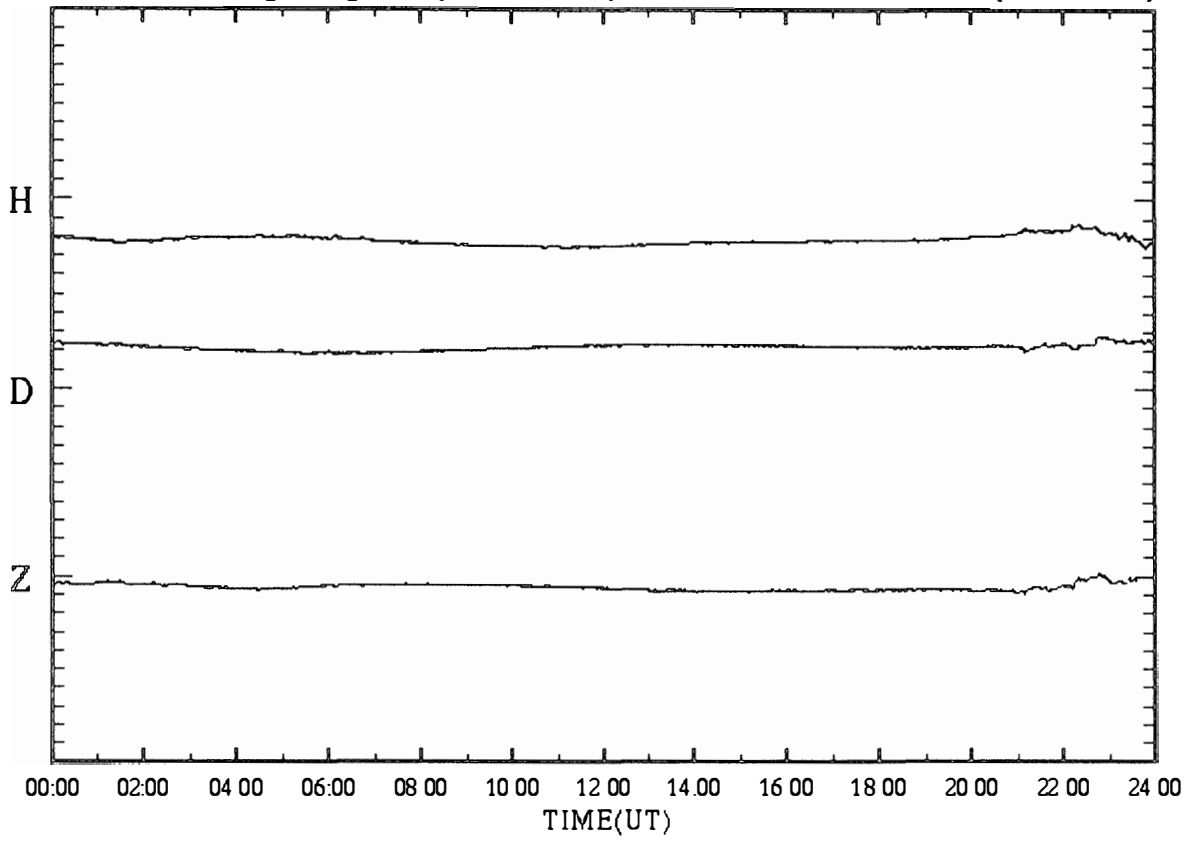



SYOWA magnetogram (100 nT/div)

22 Nov.1997 (DAY:326)

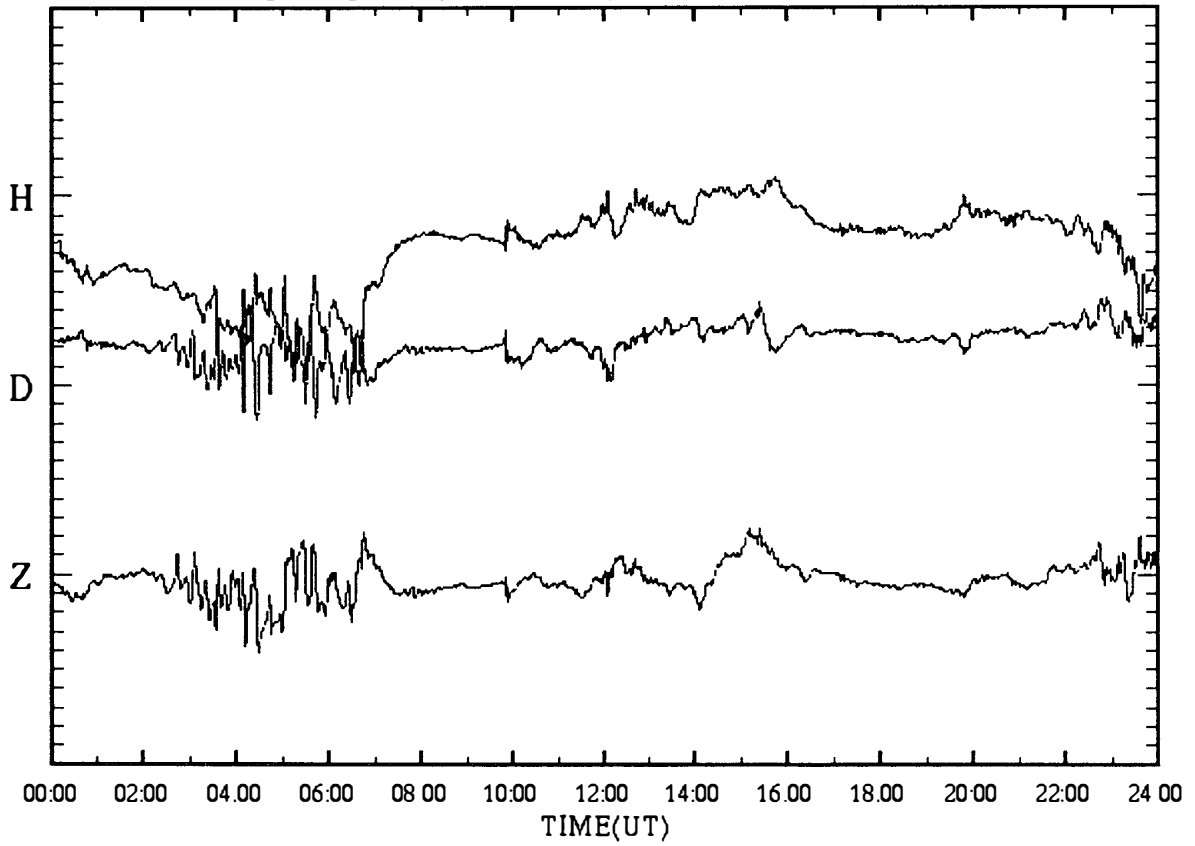

SYOWA magnetogram (100 nT/div)

23 Nov.1997 (DAY:327)

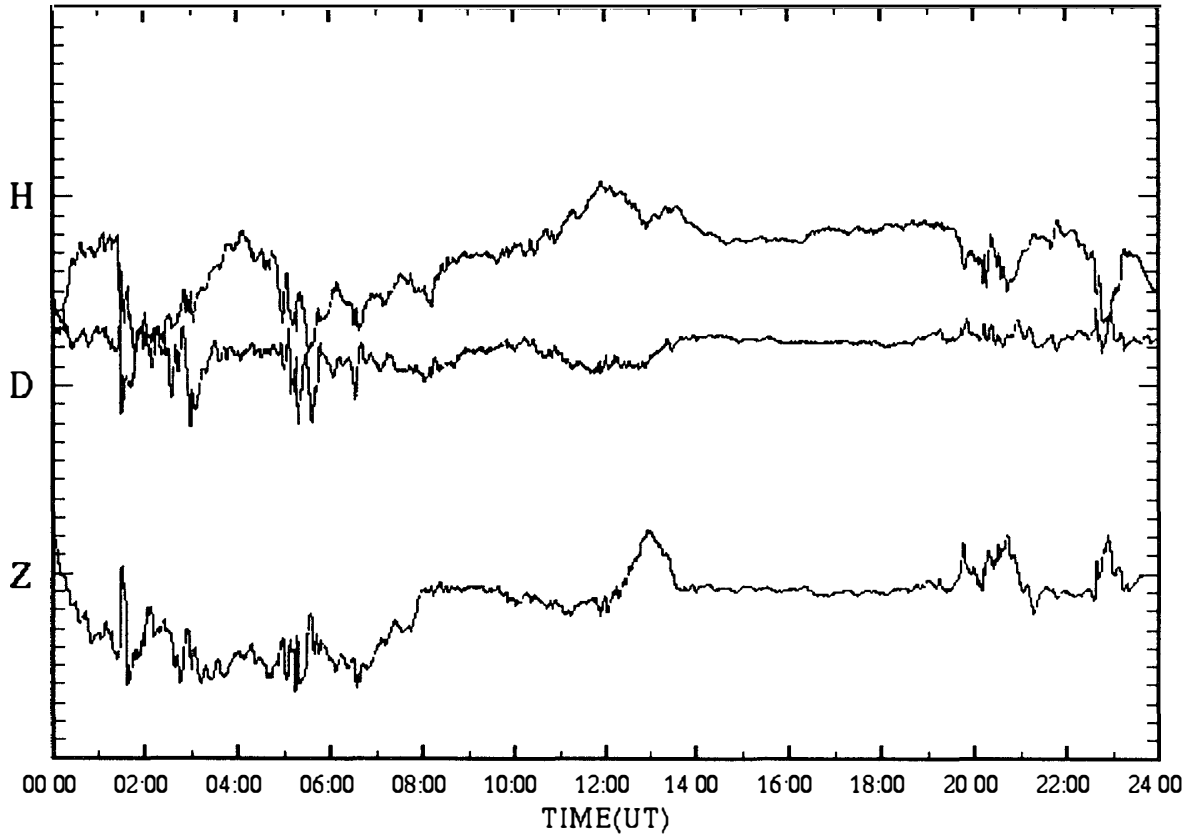

SYOWA magnetogram (100 nT/div)

24 Nov.1997 (DAY:328)

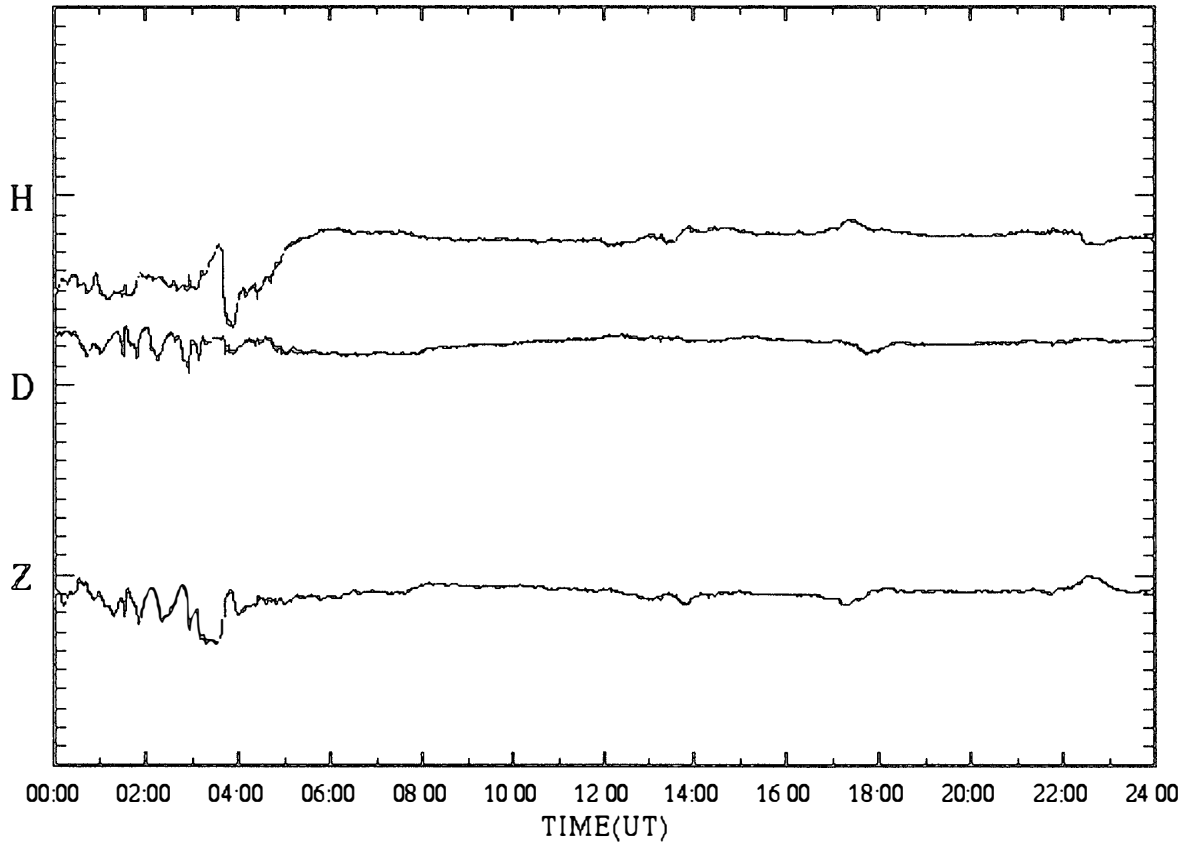

SYOWA magnetogram (100 nT/div)

25 Nov.1997 (DAY:329)

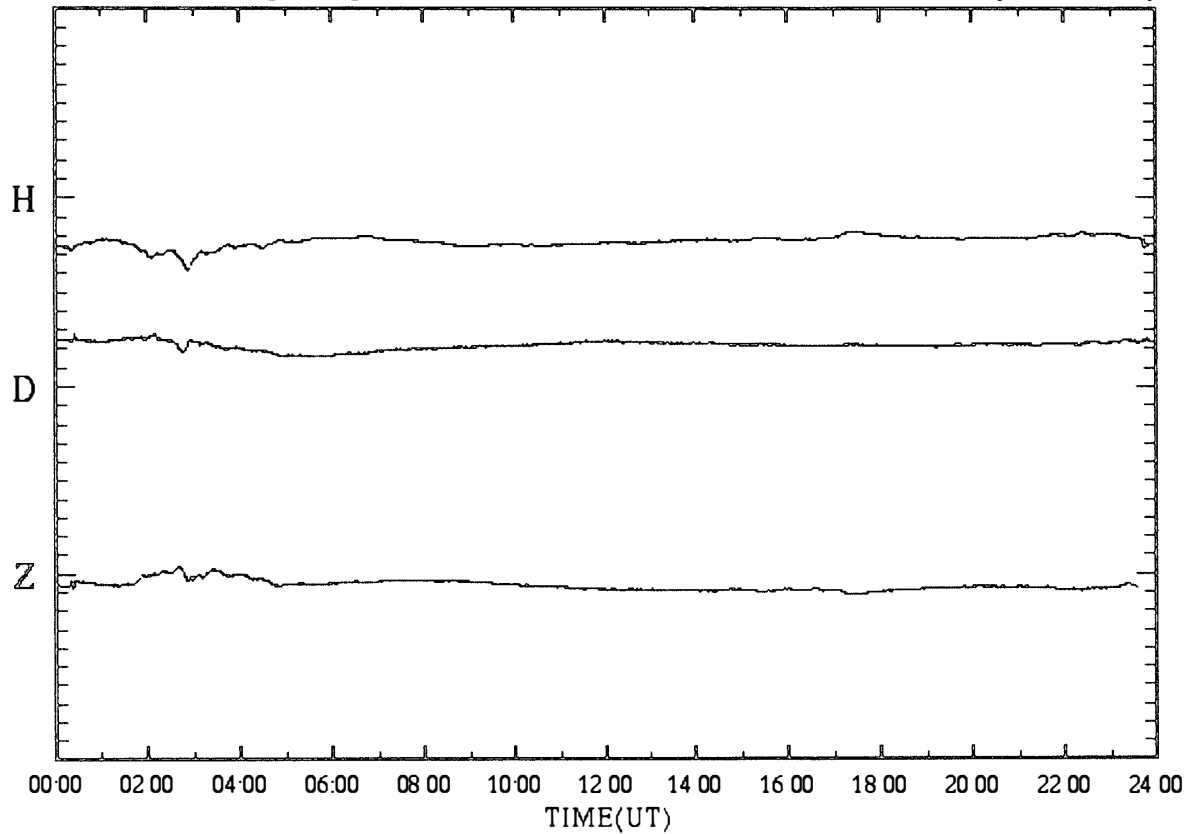

SYOWA magnetogram (100 nT/div)

26 Nov.1997 (DAY:330)

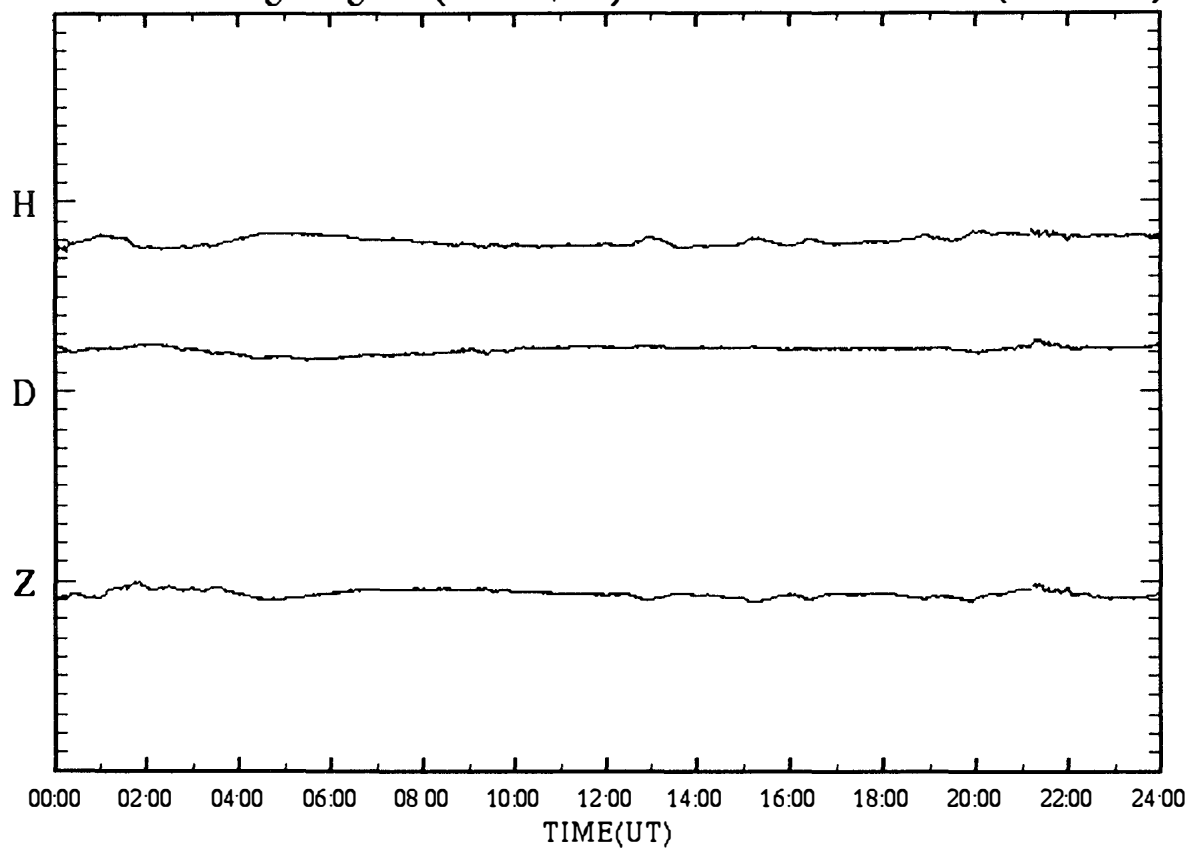

SYOWA magnetogram (100 nT/div)

27 Nov.1997 (DAY:331)

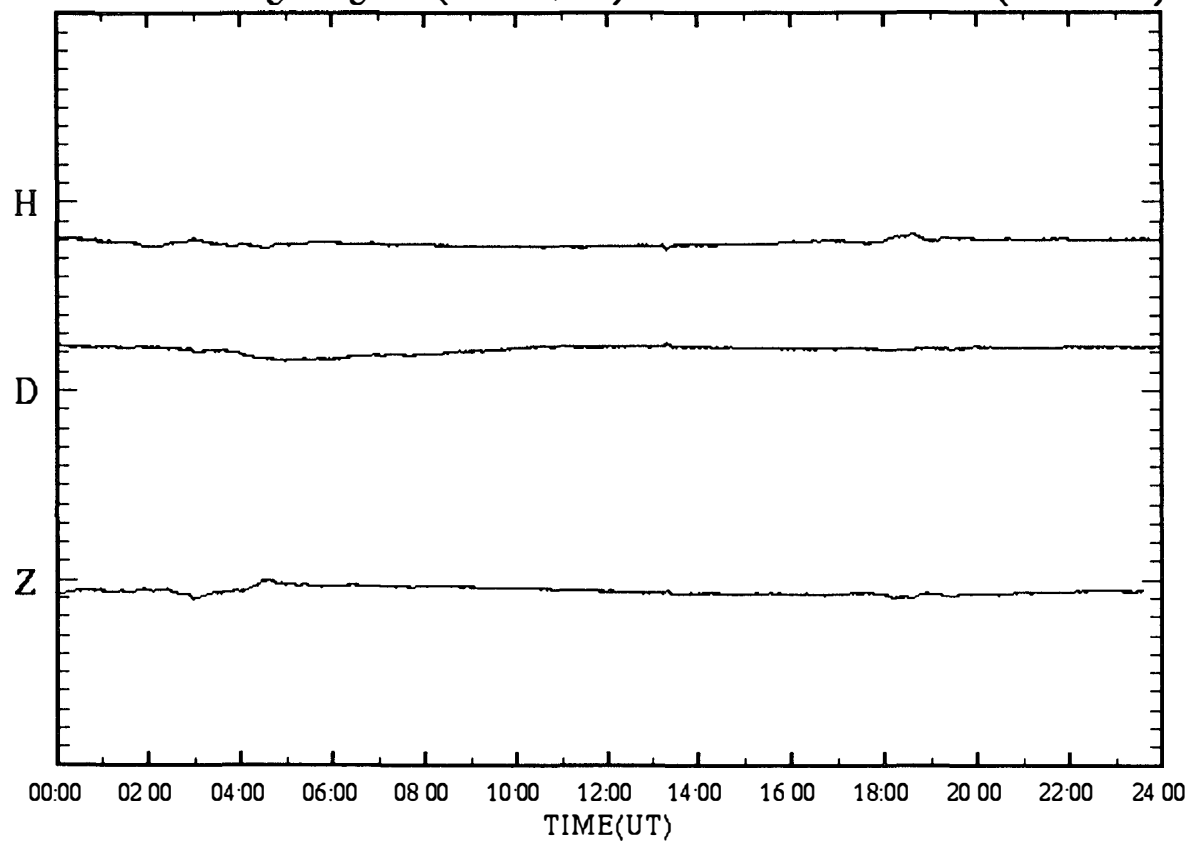

SYOWA magnetogram (100 nT/div)

28 Nov.1997 (DAY:332)

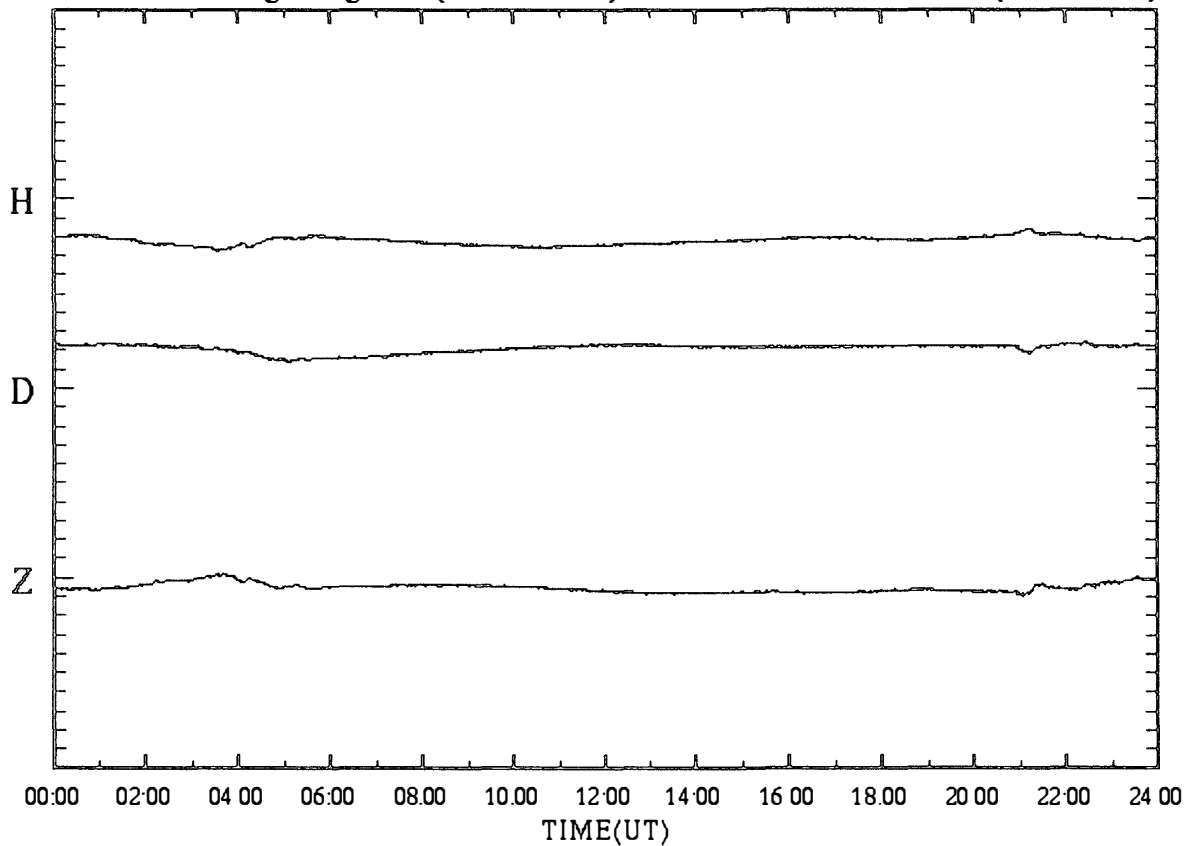

SYOWA magnetogram (100 nT/div)

29 Nov.1997 (DAY:333)

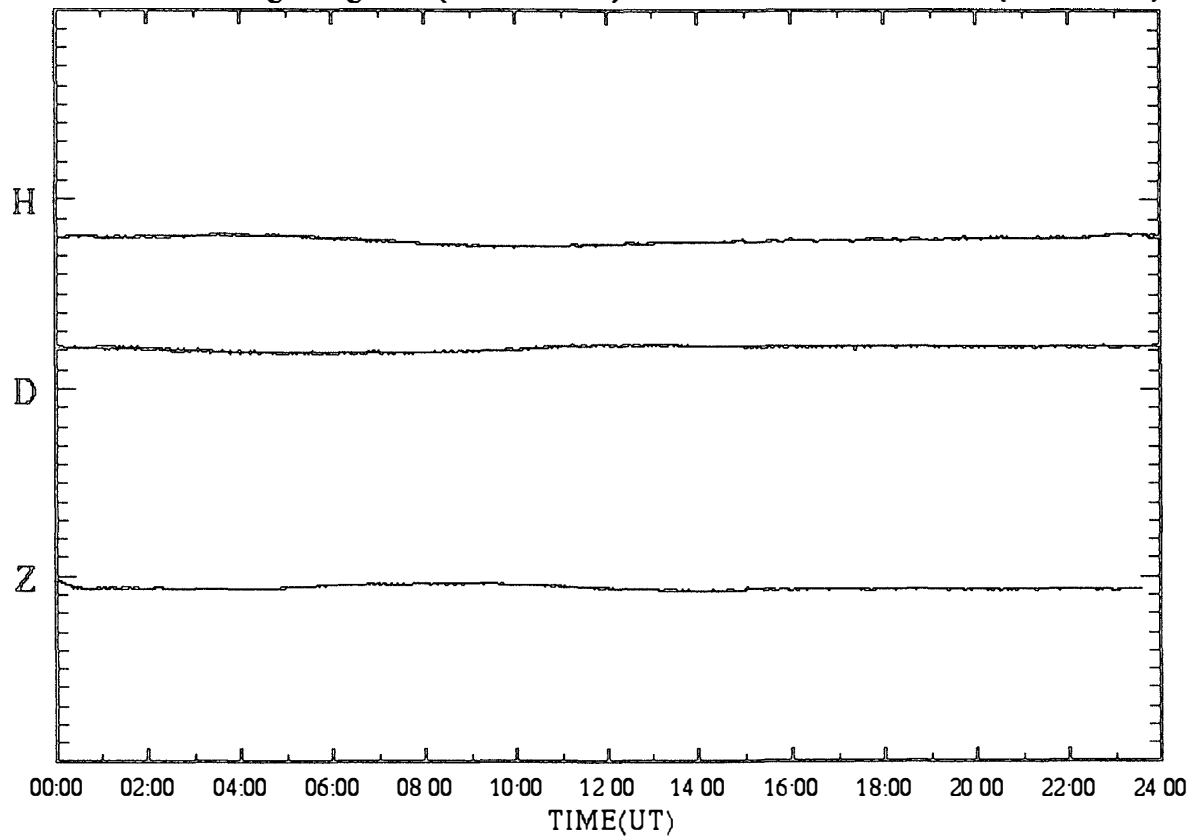

SYOWA magnetogram (100 nT/div)

30 Nov.1997 (DAY:334)

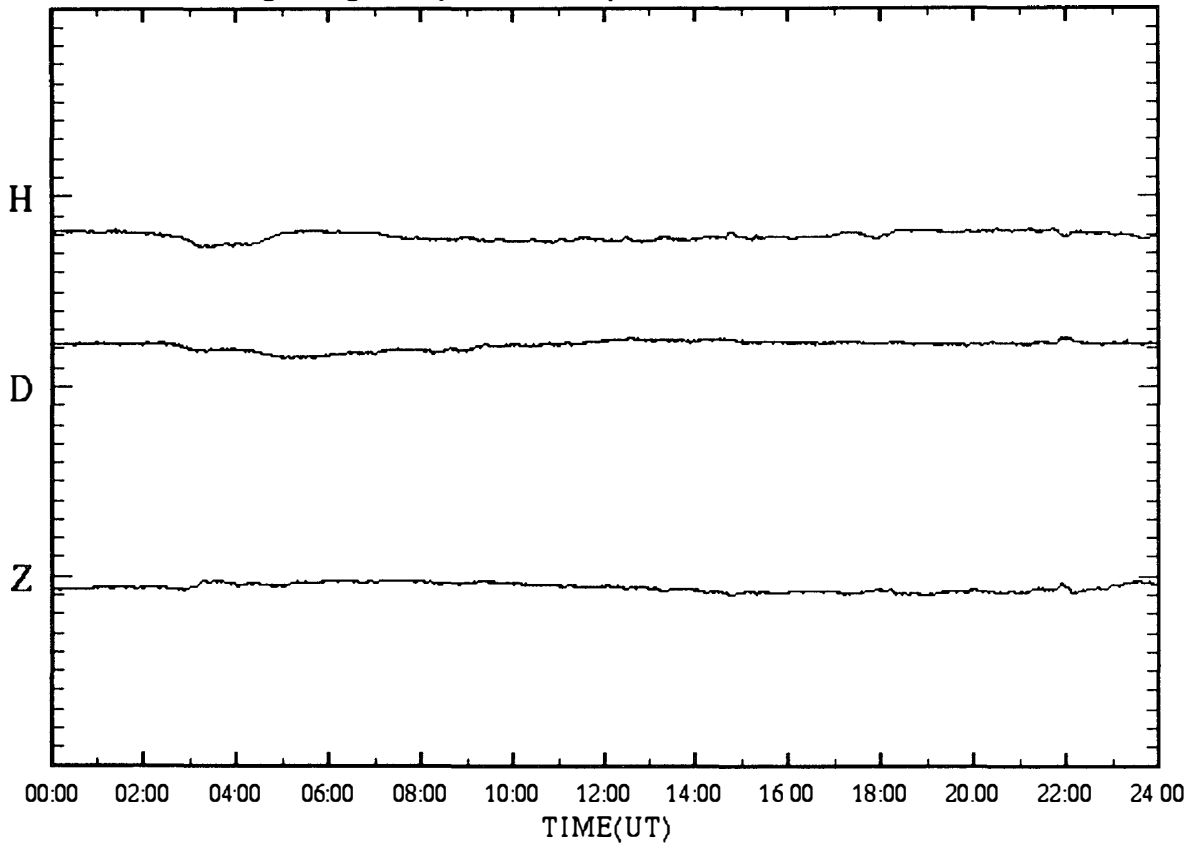

SYOWA magnetogram (100 nT/div)

01 Dec.1997 (DAY:335)

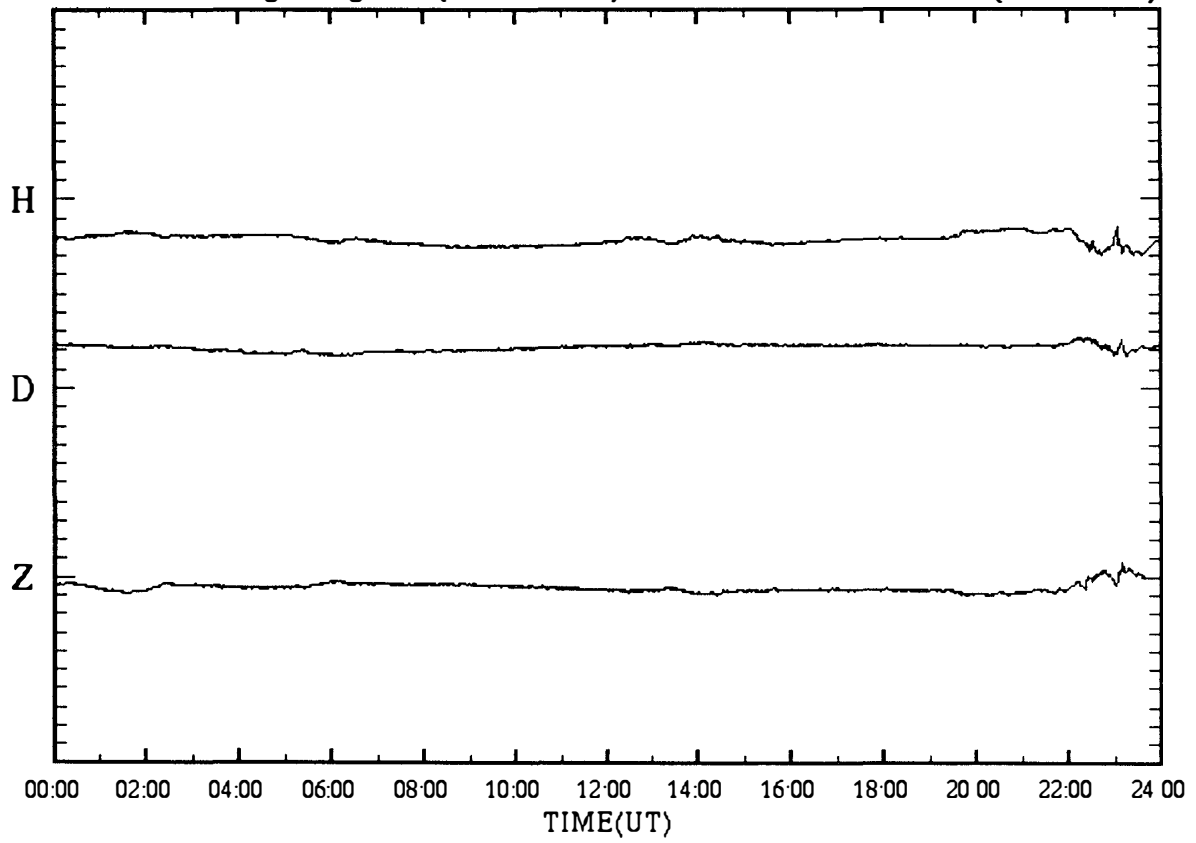

SYOWA magnetogram (100 nT/div)

02 Dec.1997 (DAY:336)

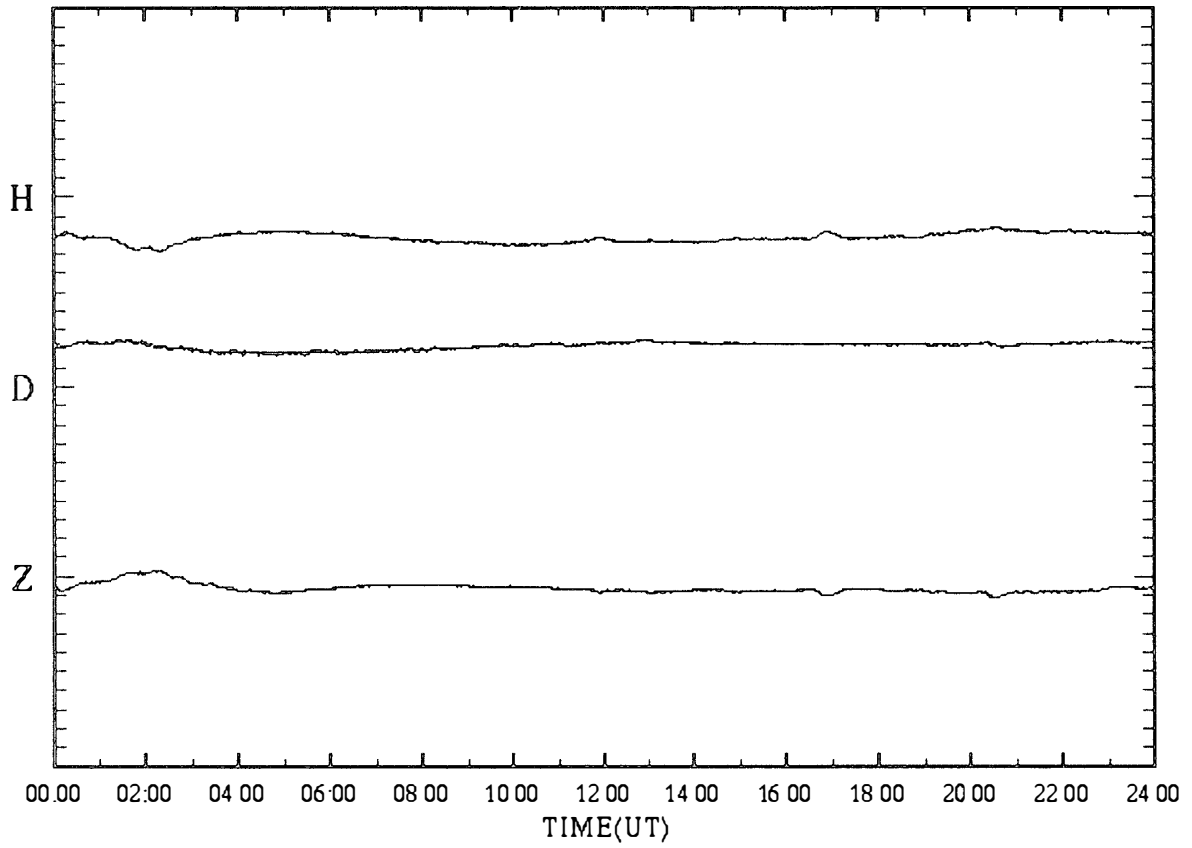

SYOWA magnetogram (100 nT/div)

03 Dec.1997 (DAY:337)

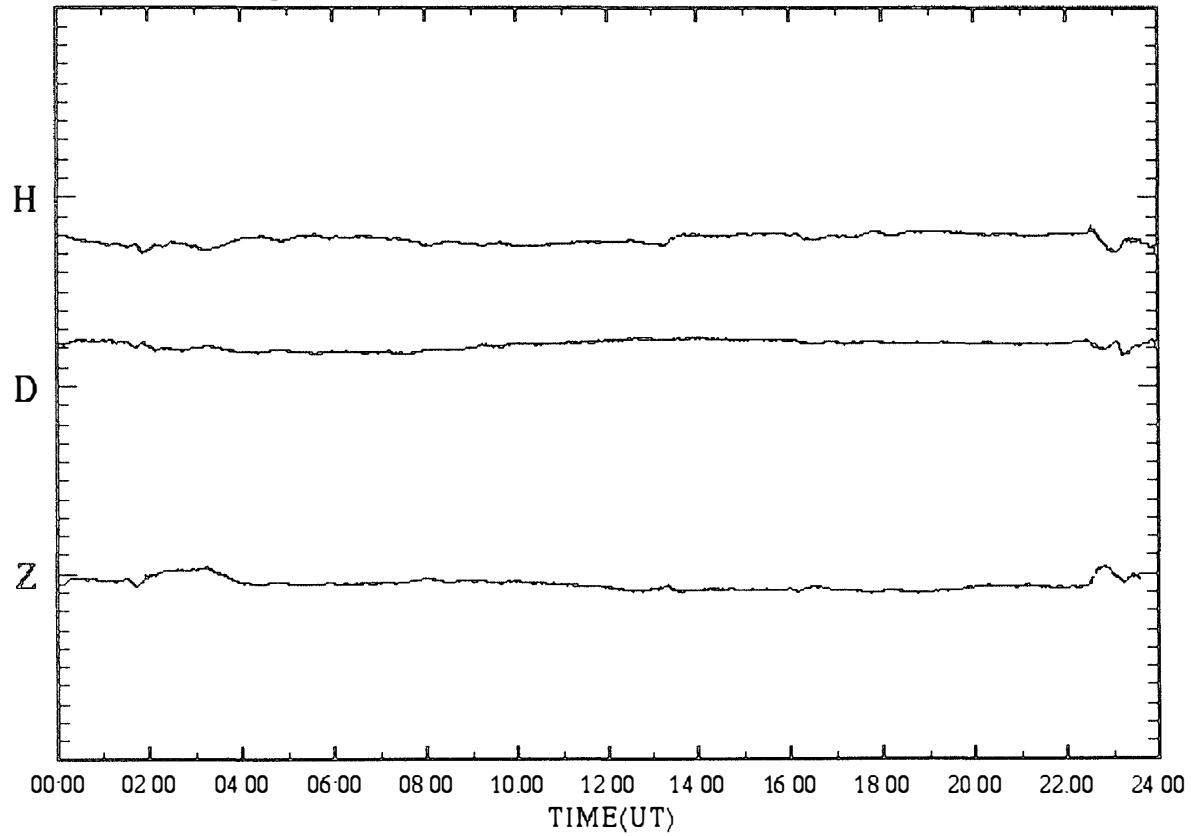

SYOWA magnetogram (100 nT/div)

04 Dec.1997 (DAY:338)

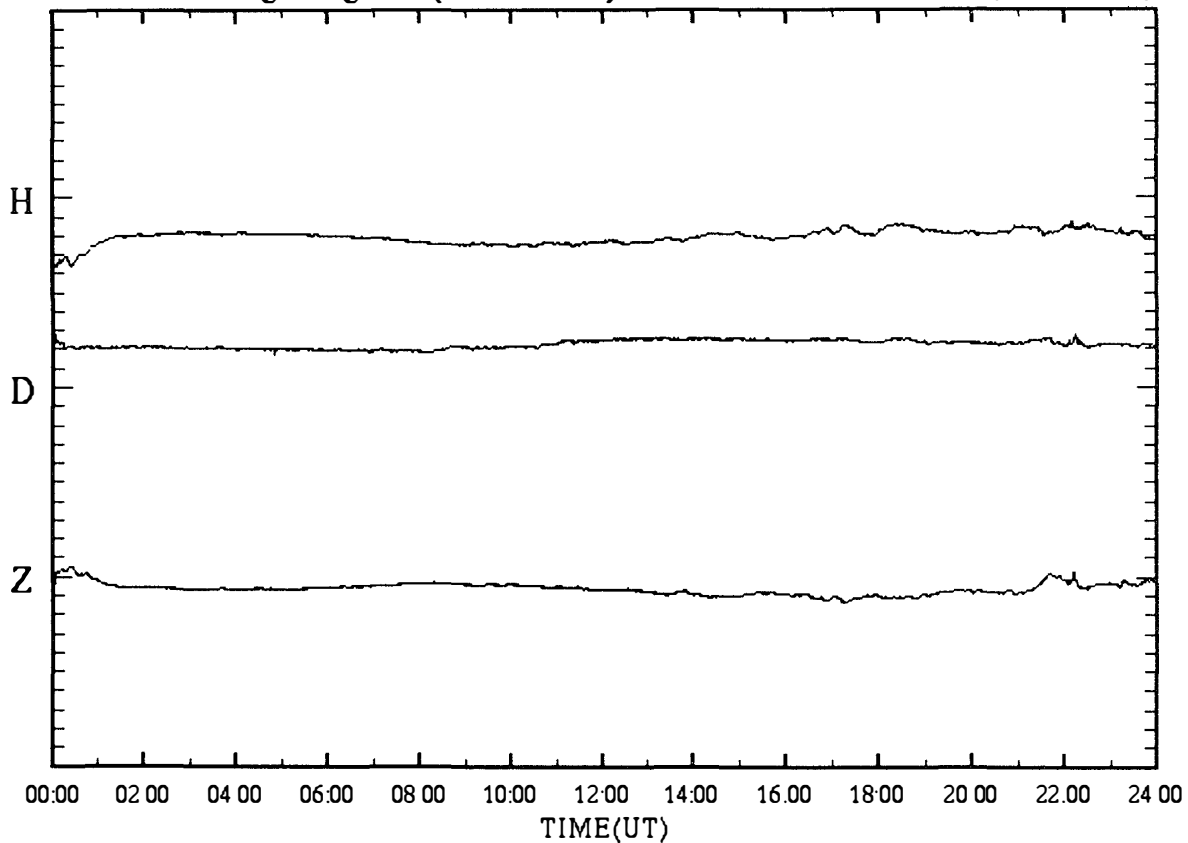

SYOWA magnetogram (100 nT/div)

05 Dec.1997 (DAY:339)

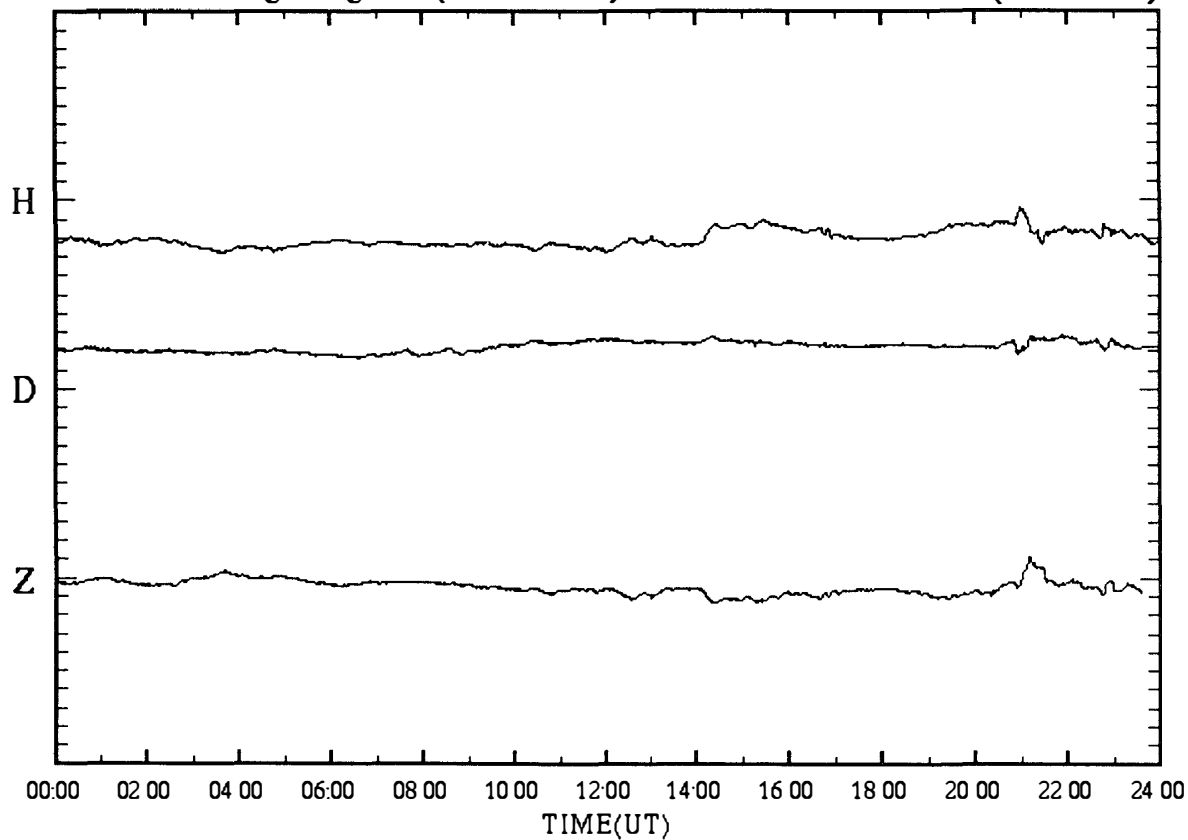

SYOWA magnetogram (100 nT/div)

06 Dec.1997 (DAY:340)

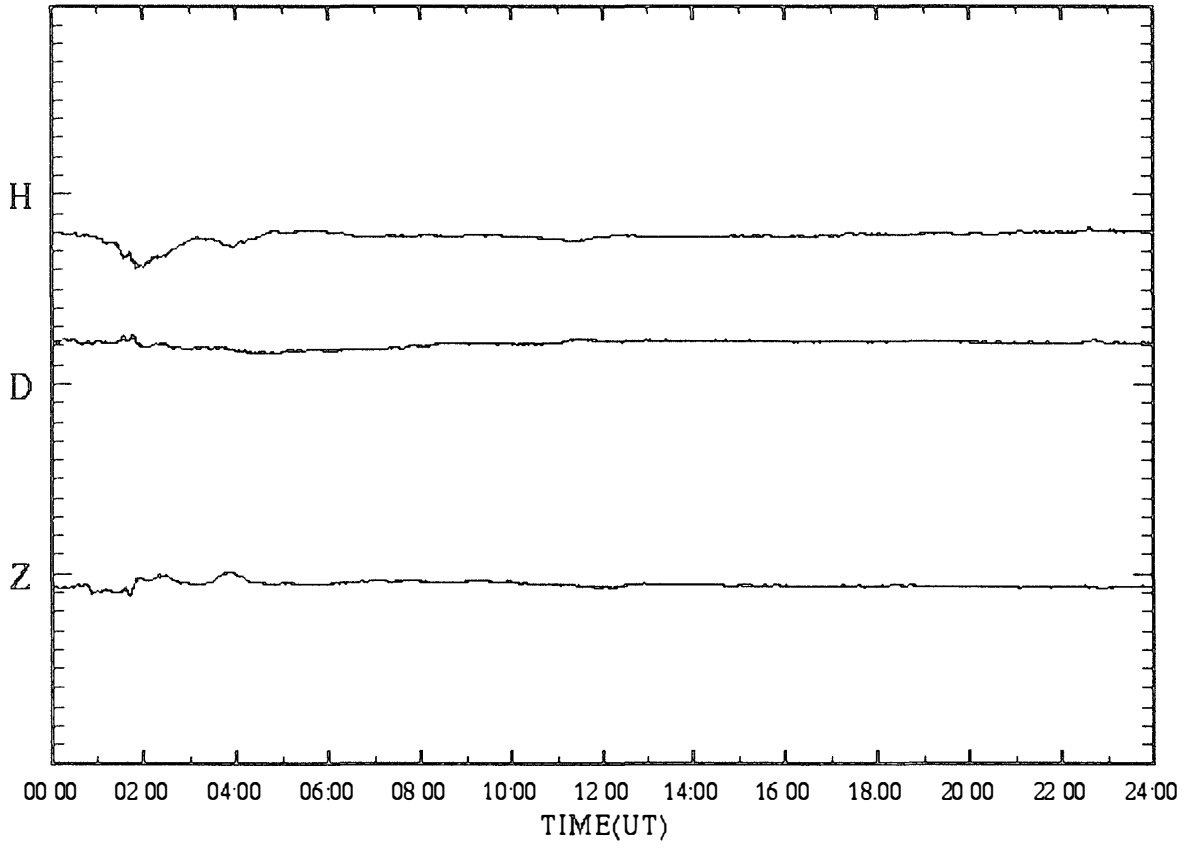

SYOWA magnetogram (100 nT/div)

07 Dec.1997 (DAY:341)

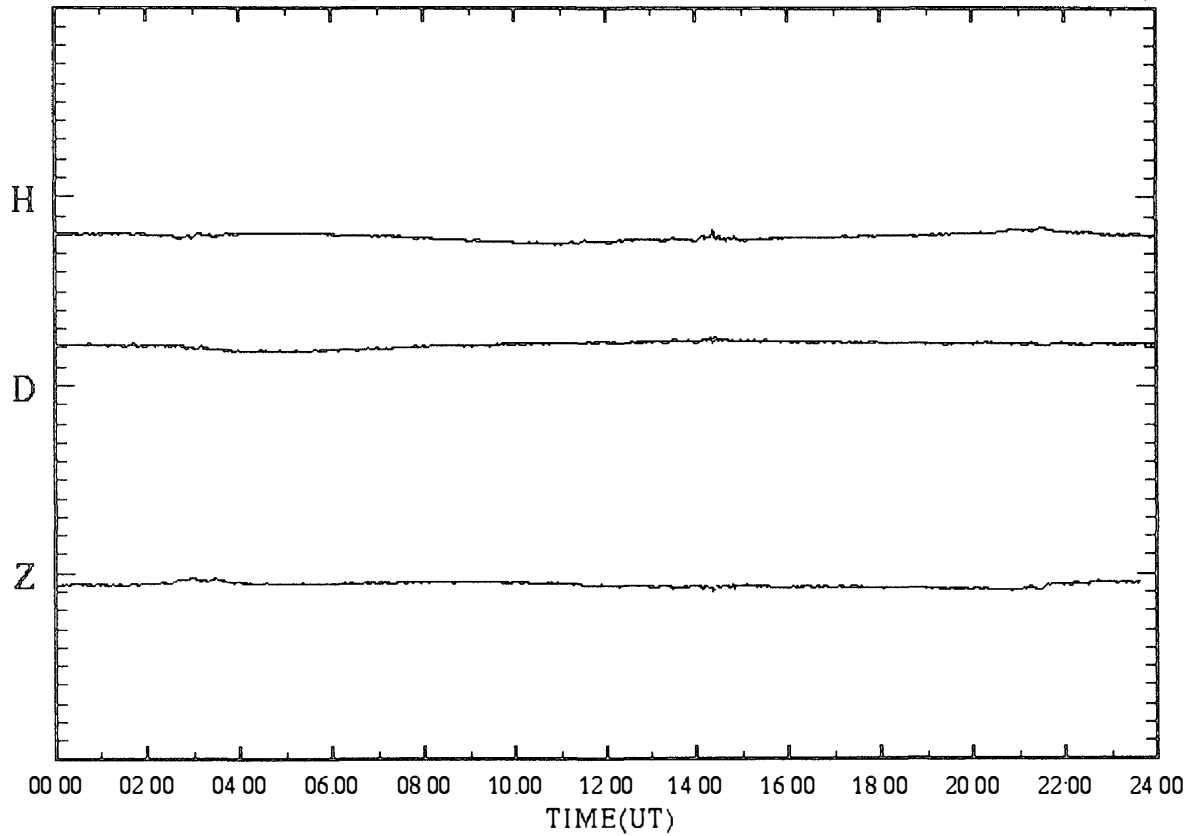



SYOWA magnetogram (100 nT/div)

08 Dec.1997 (DAY:342)

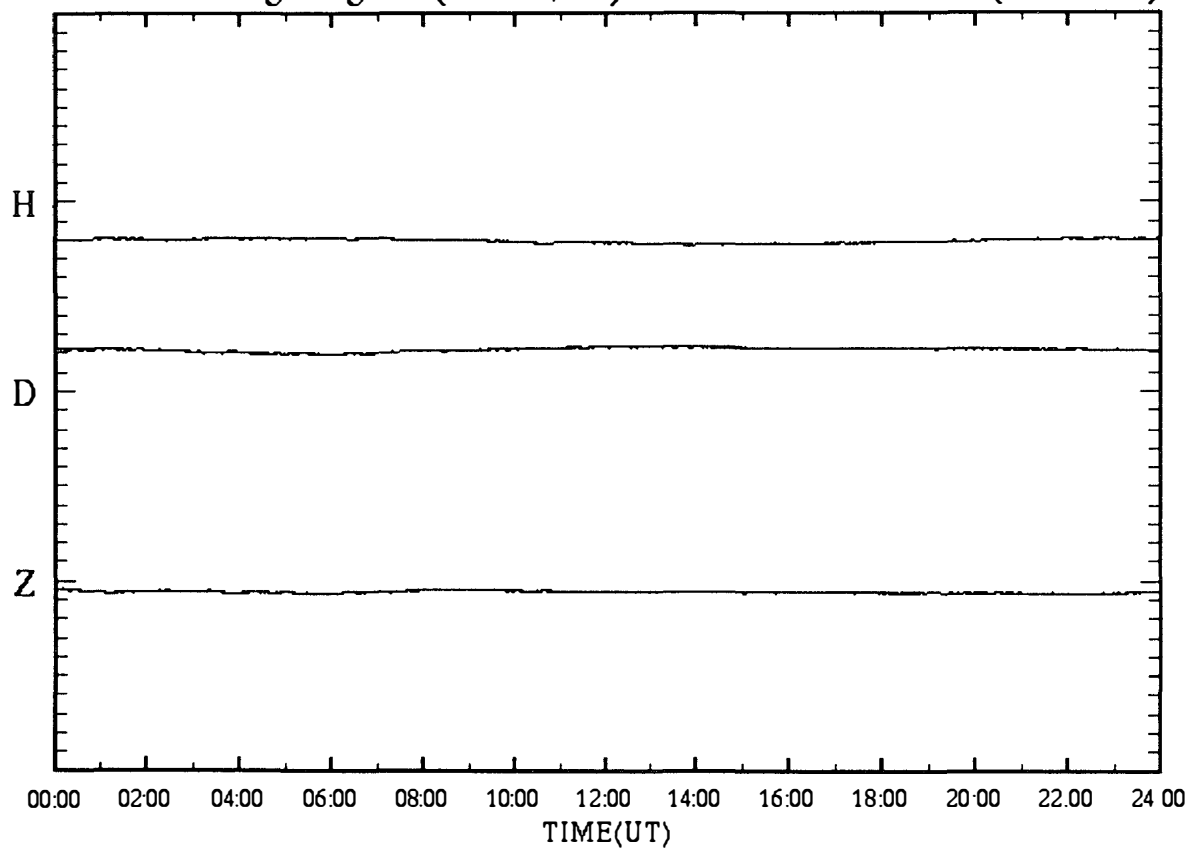

SYOWA magnetogram (100 nT/div)

09 Dec.1997 (DAY:343)

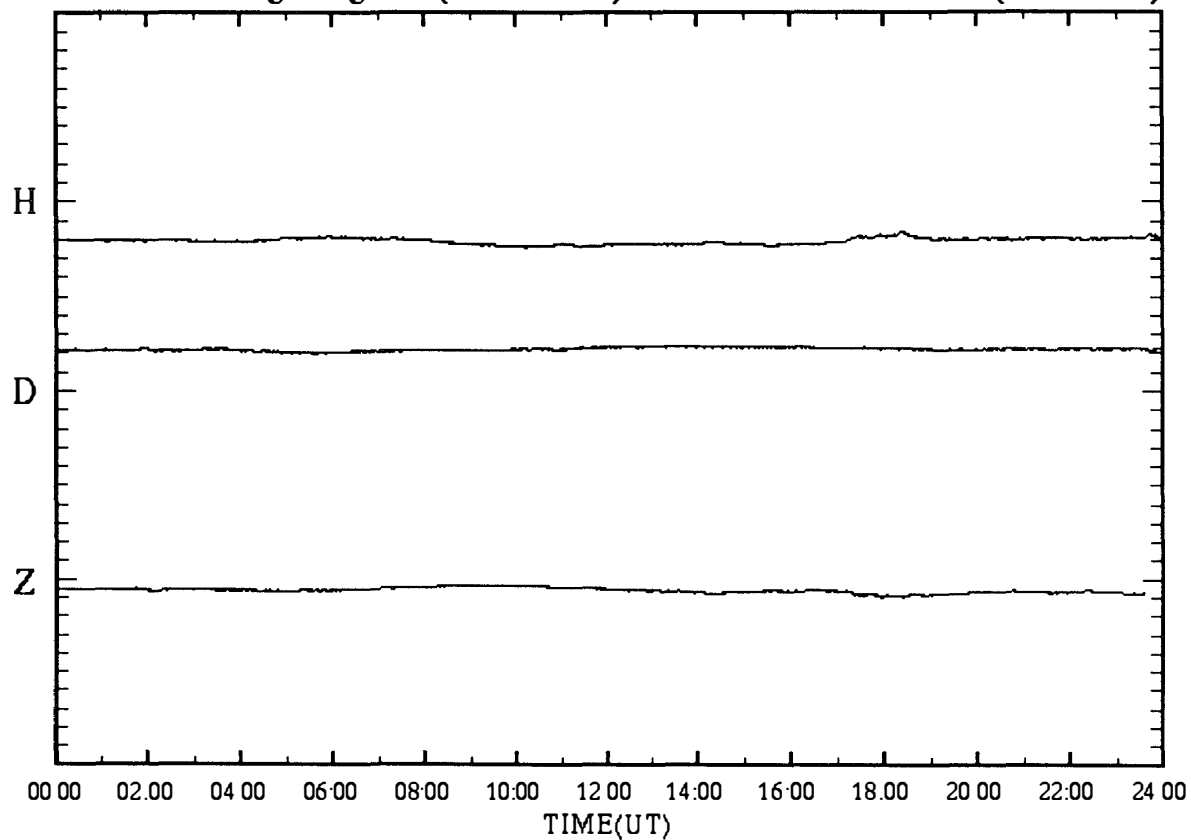

SYOWA magnetogram (100 nT/div)

10 Dec.1997 (DAY:344)

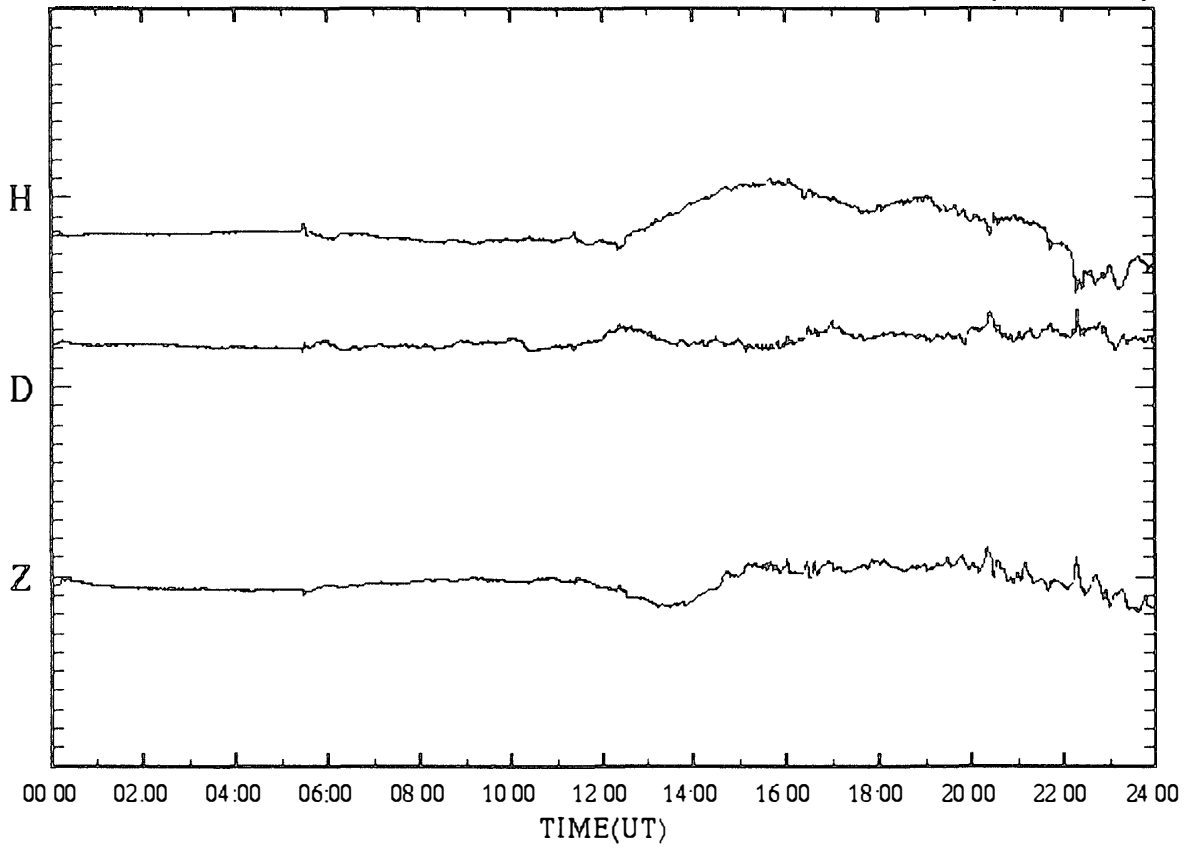

SYOWA magnetogram (100 nT/div)

11 Dec.1997 (DAY:345)

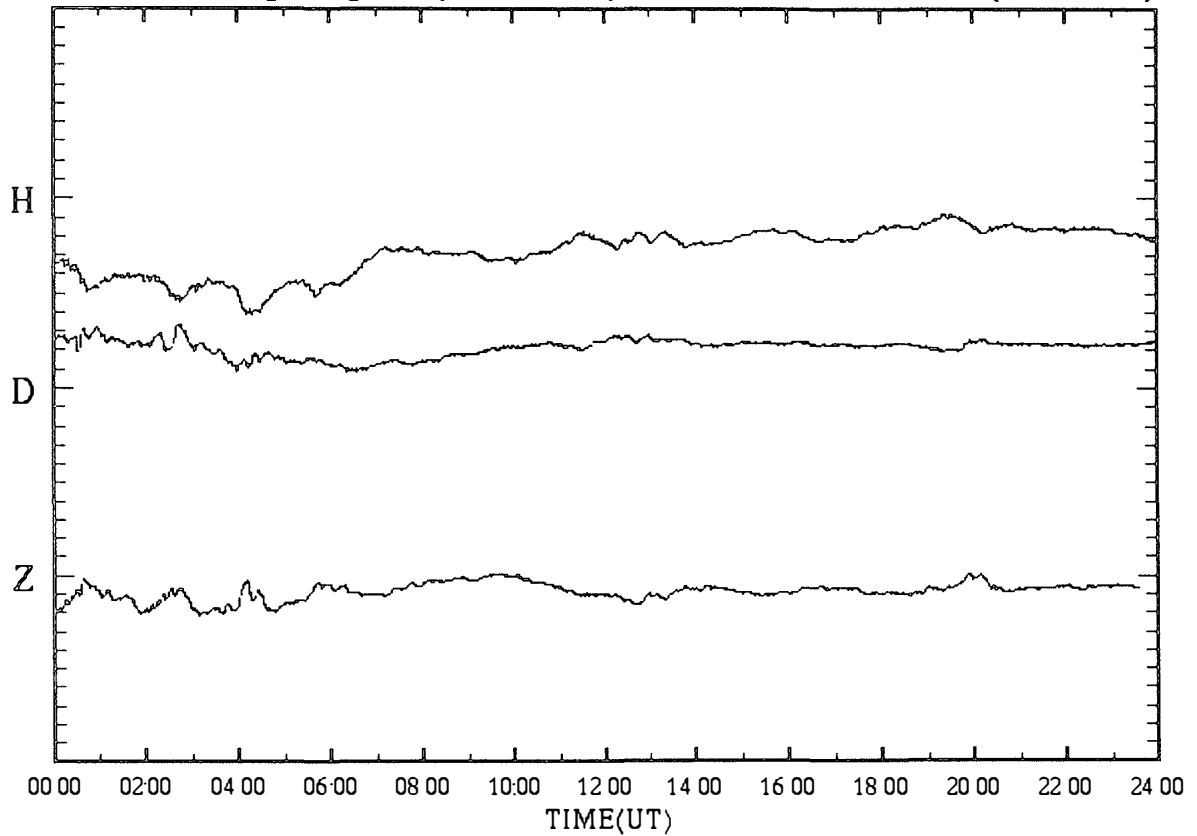

SYOWA magnetogram (100 nT/div)

12 Dec.1997 (DAY:346)

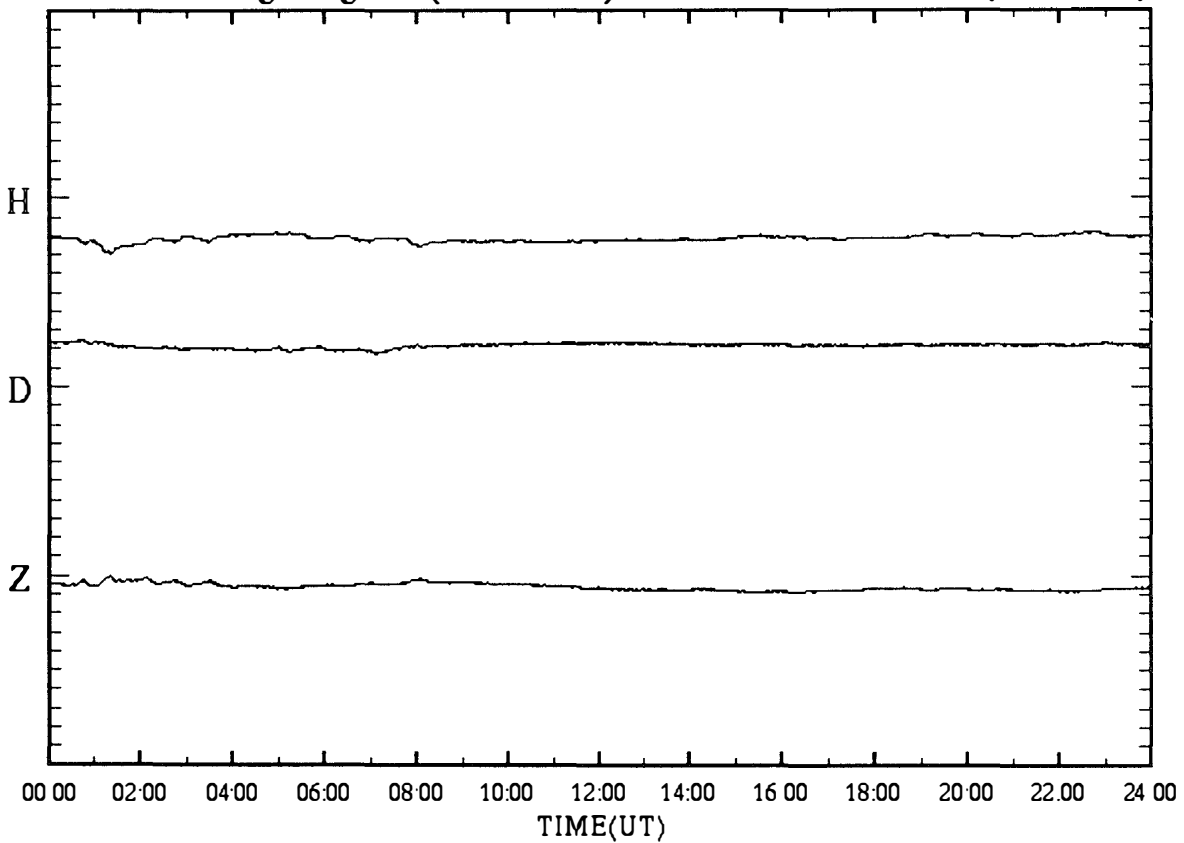

SYOWA magnetogram (100 nT/div)

13 Dec.1997 (DAY:347)

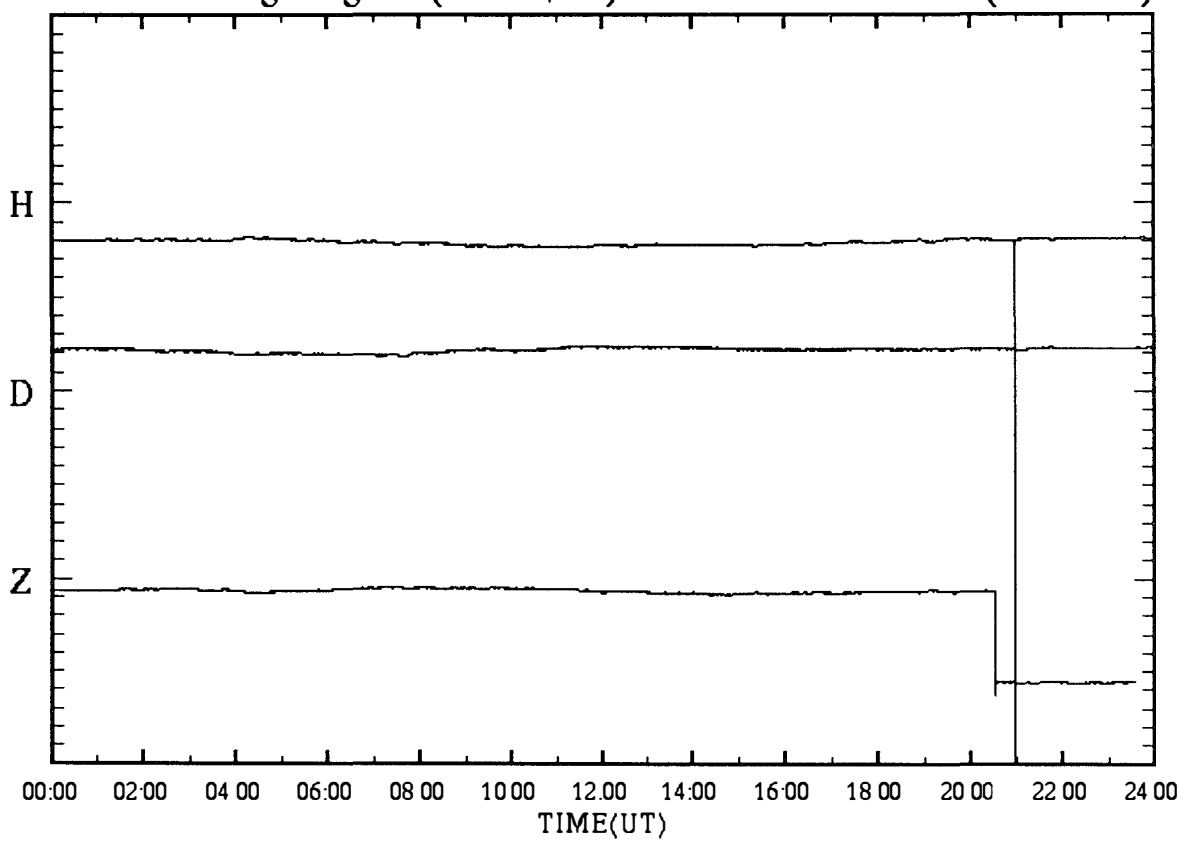

SYOWA magnetogram (100 nT/div)

14 Dec.1997 (DAY:348)

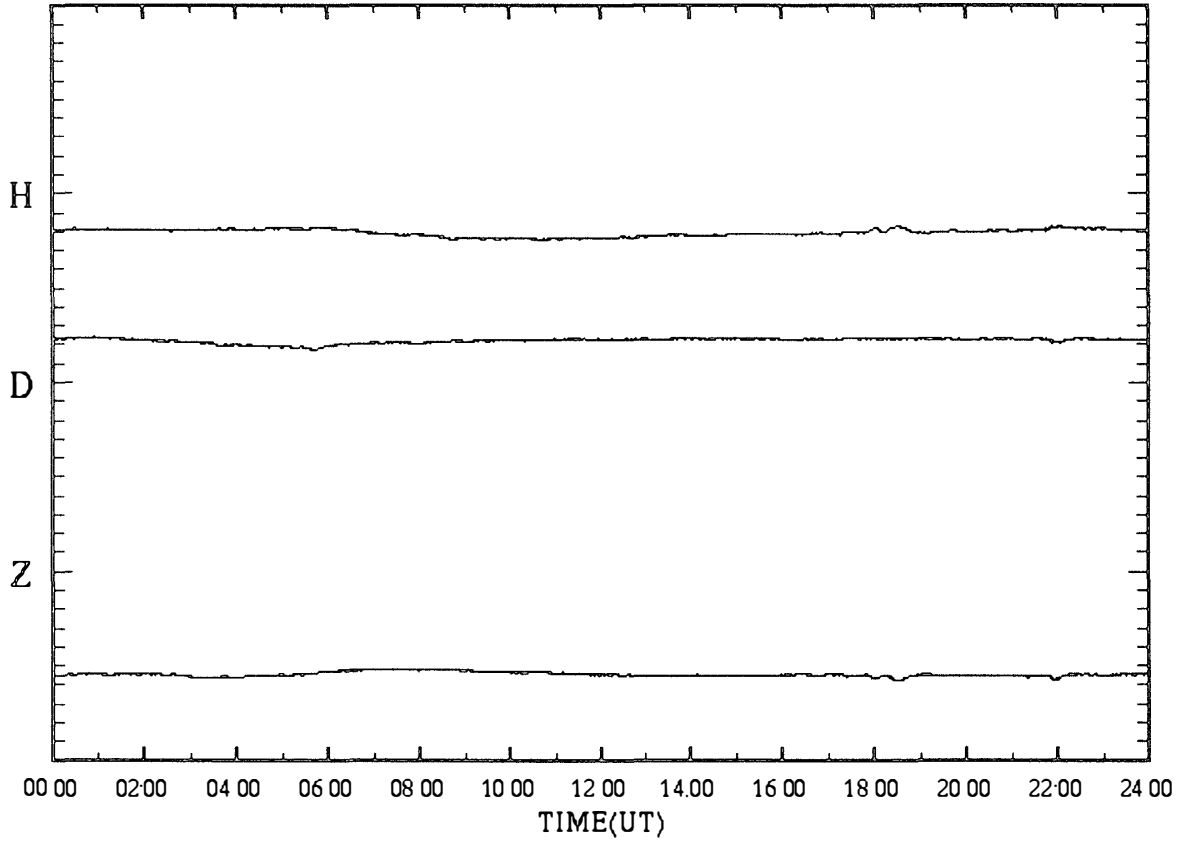

SYOWA magnetogram (100 nT/div)

15 Dec.1997 (DAY:349)

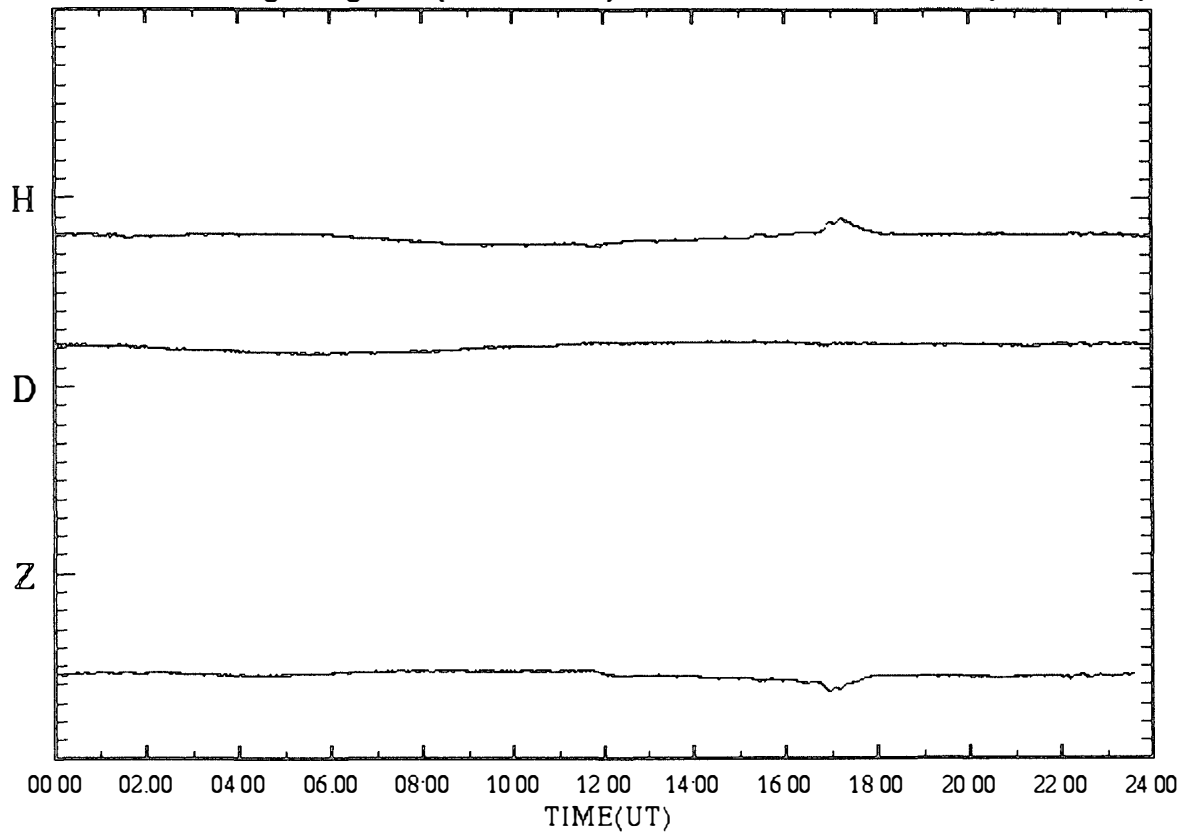

SYOWA magnetogram (100 nT/div)

16 Dec.1997 (DAY:350)

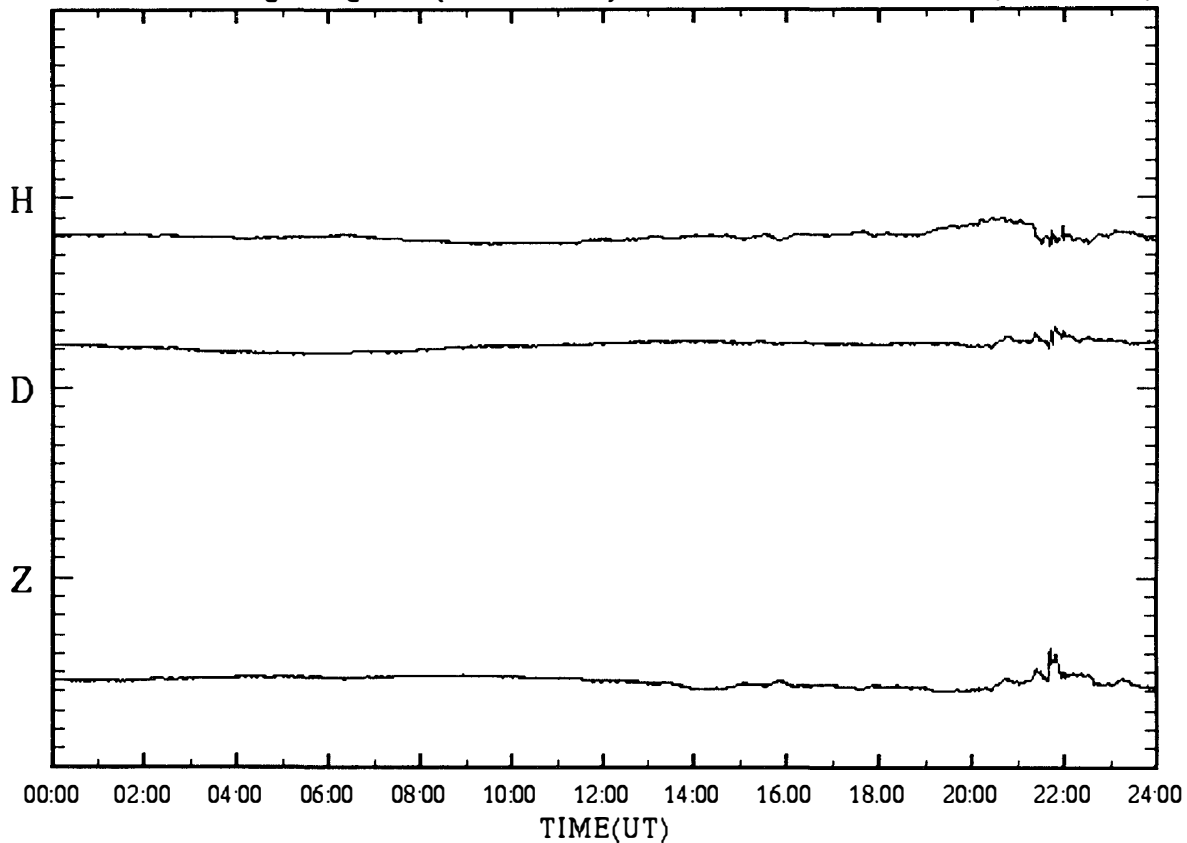

SYOWA magnetogram (100 nT/div)

17 Dec.1997 (DAY:351)

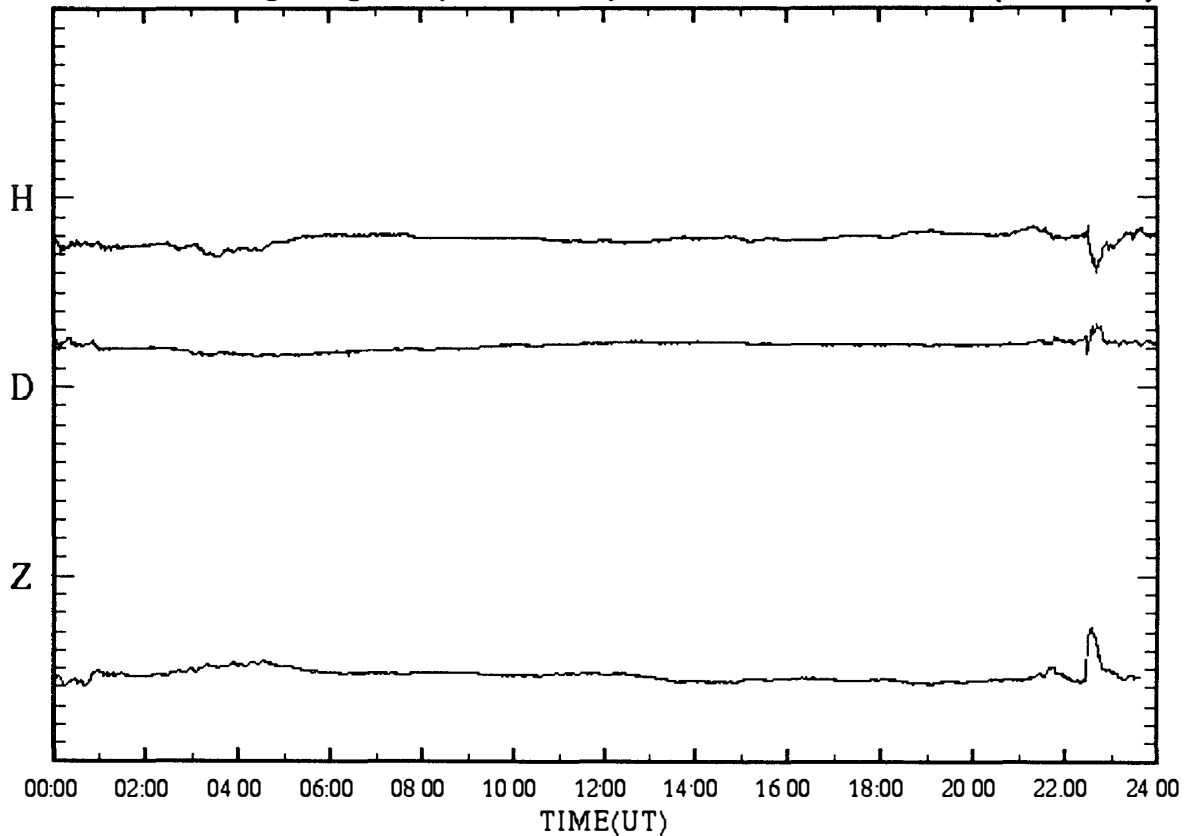

SYOWA magnetogram (100 nT/div)

18 Dec.1997 (DAY:352)

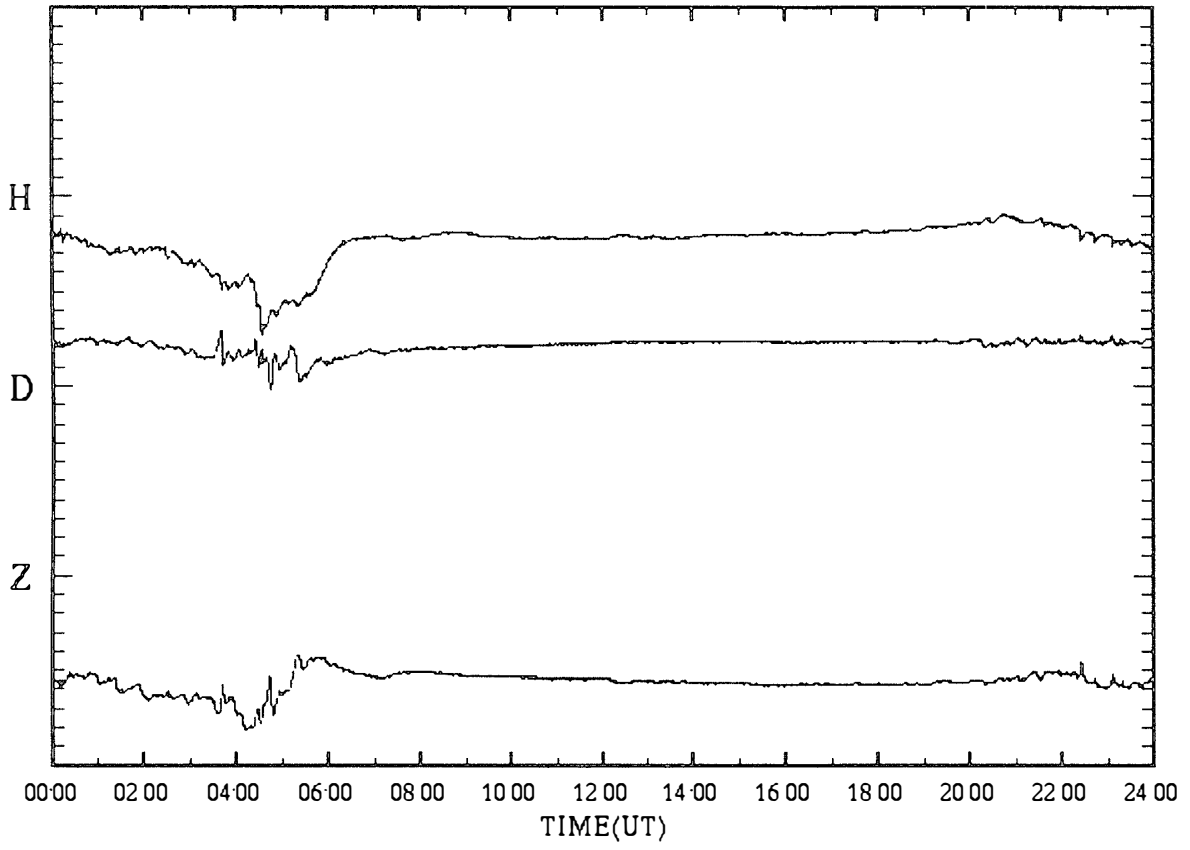

SYOWA magnetogram (100 nT/div)

19 Dec.1997 (DAY:353)

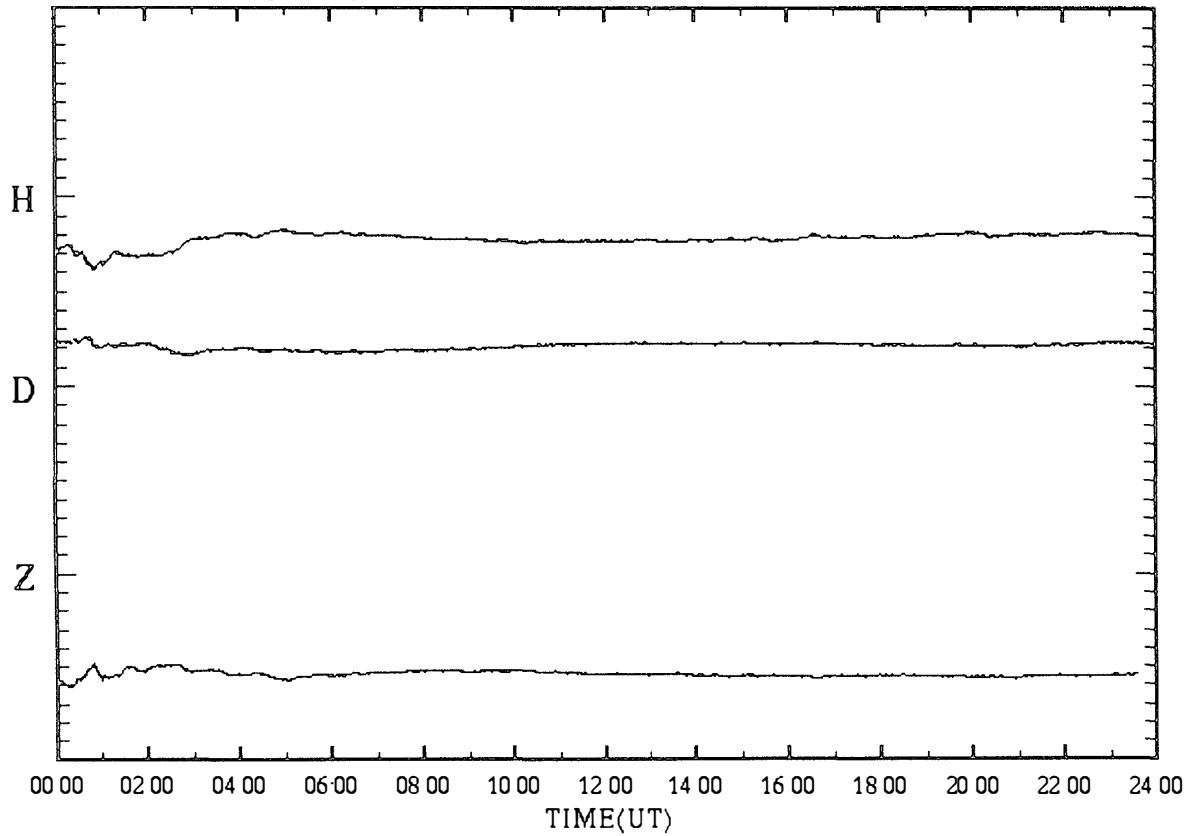

SYOWA magnetogram (100 nT/div)

20 Dec.1997 (DAY:354)

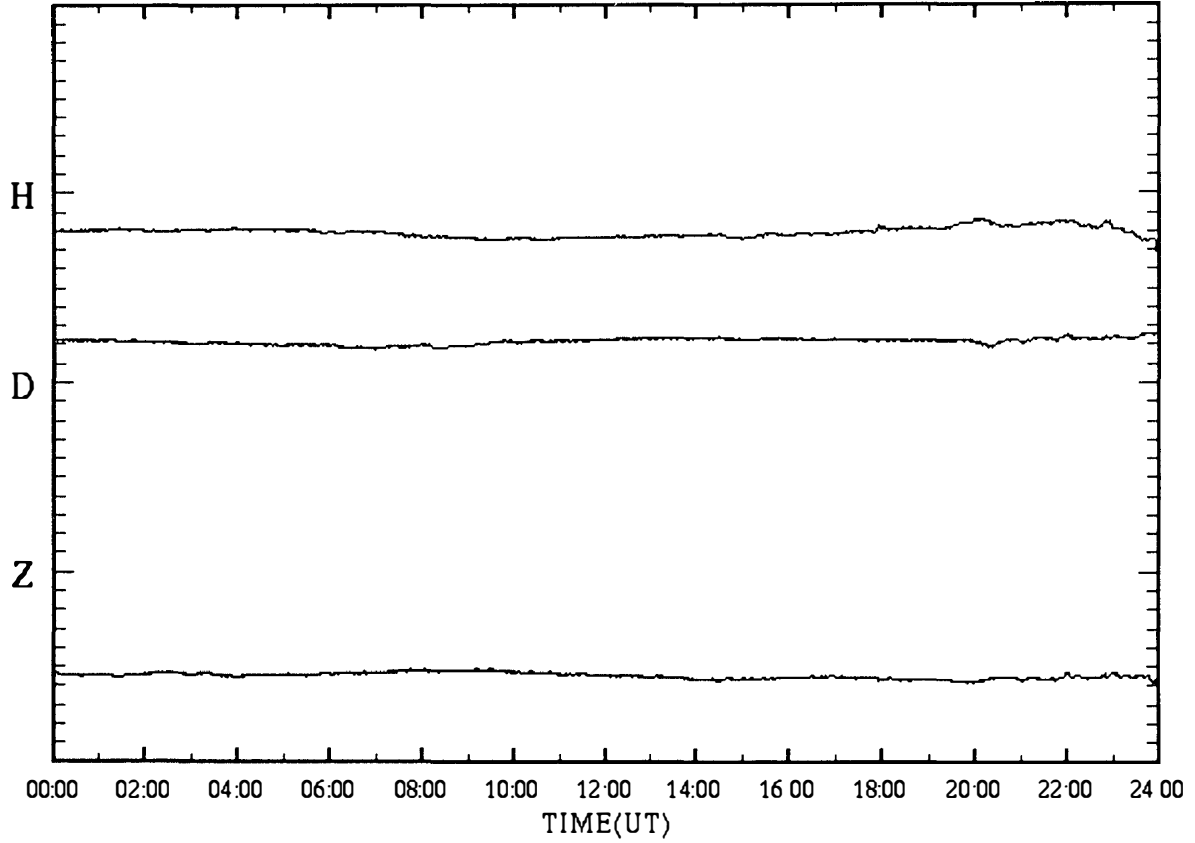

SYOWA magnetogram (100 nT/div)

21 Dec.1997 (DAY:355)

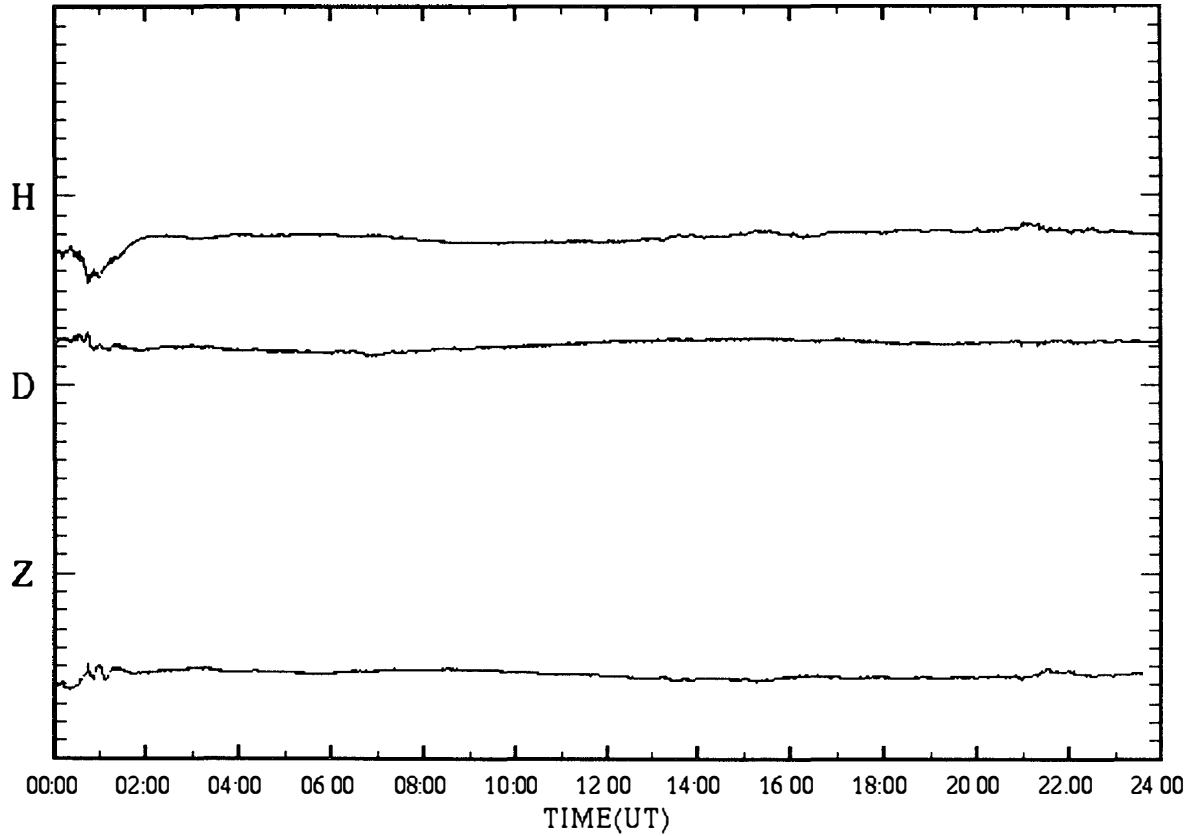

SYOWA magnetogram (100 nT/div)

22 Dec.1997 (DAY:356)

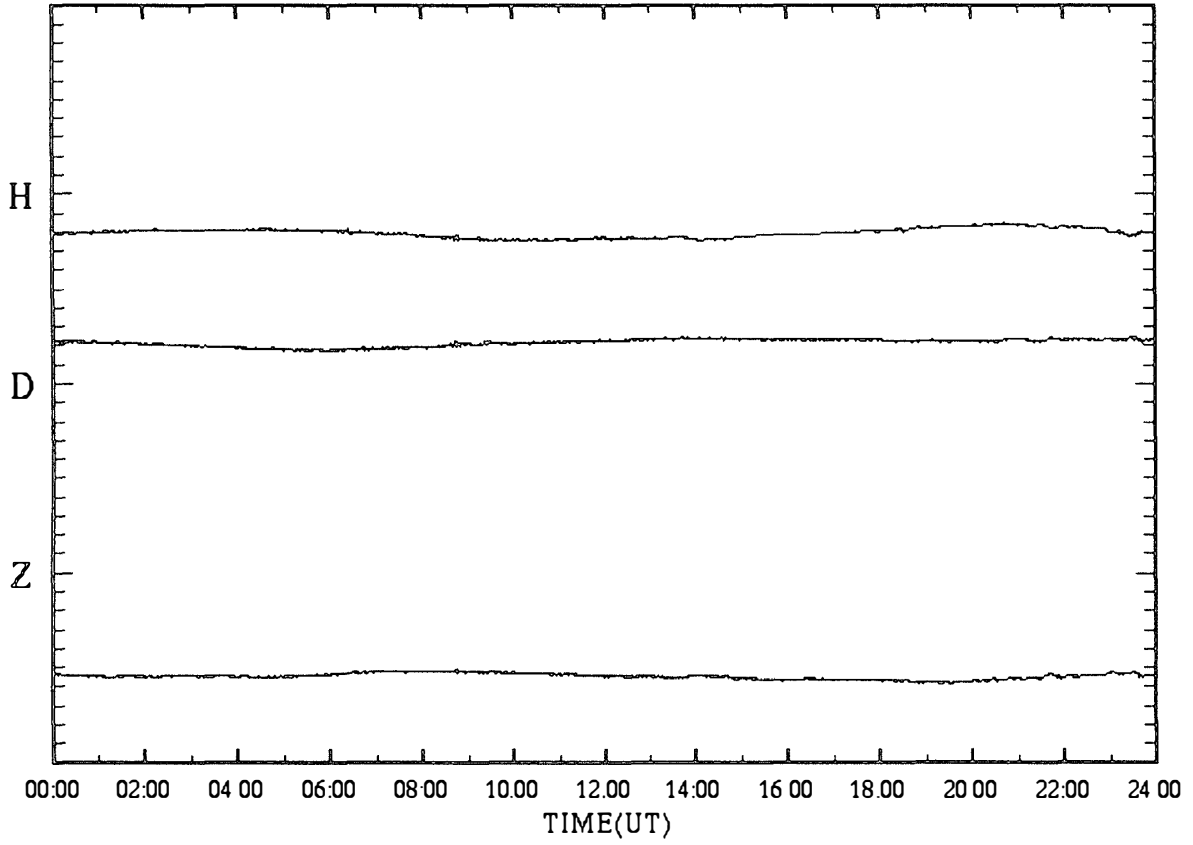

SYOWA magnetogram (100 nT/div)

23 Dec.1997 (DAY:357)

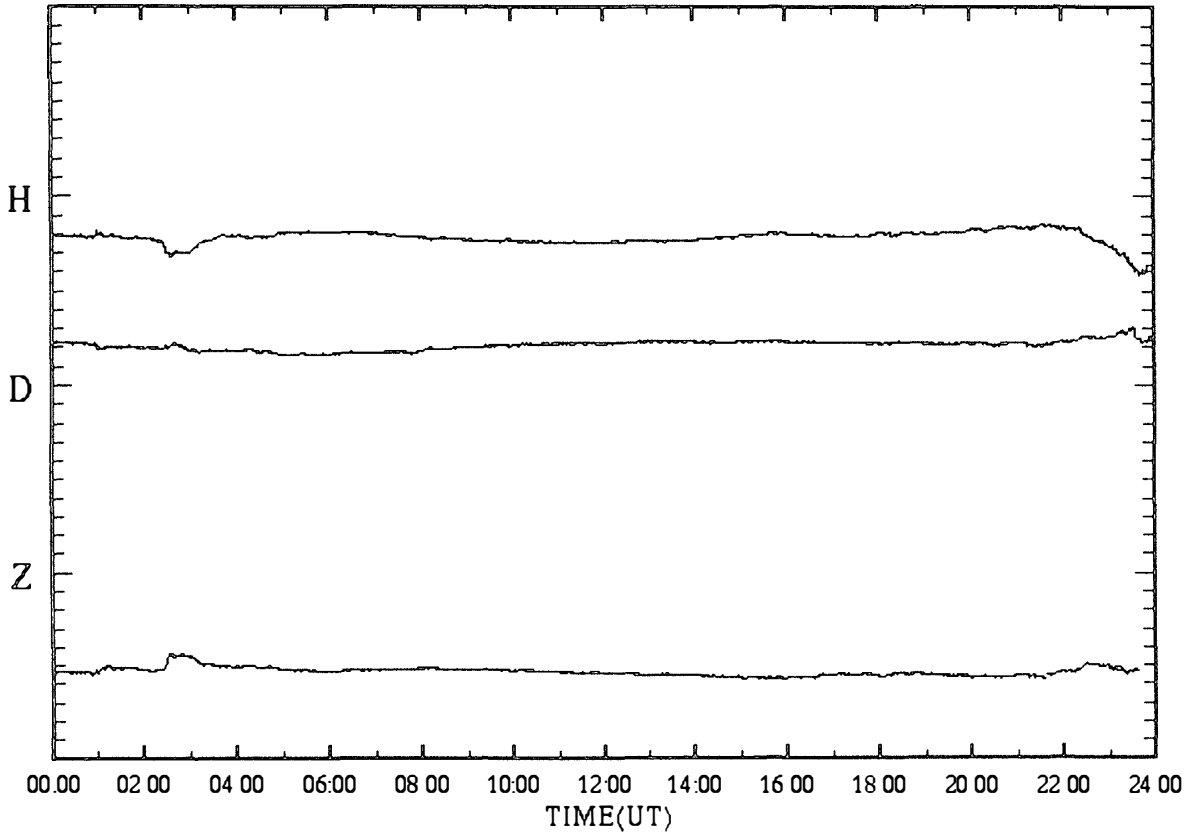



SYOWA magnetogram (100 nT/div)

24 Dec.1997 (DAY:358)

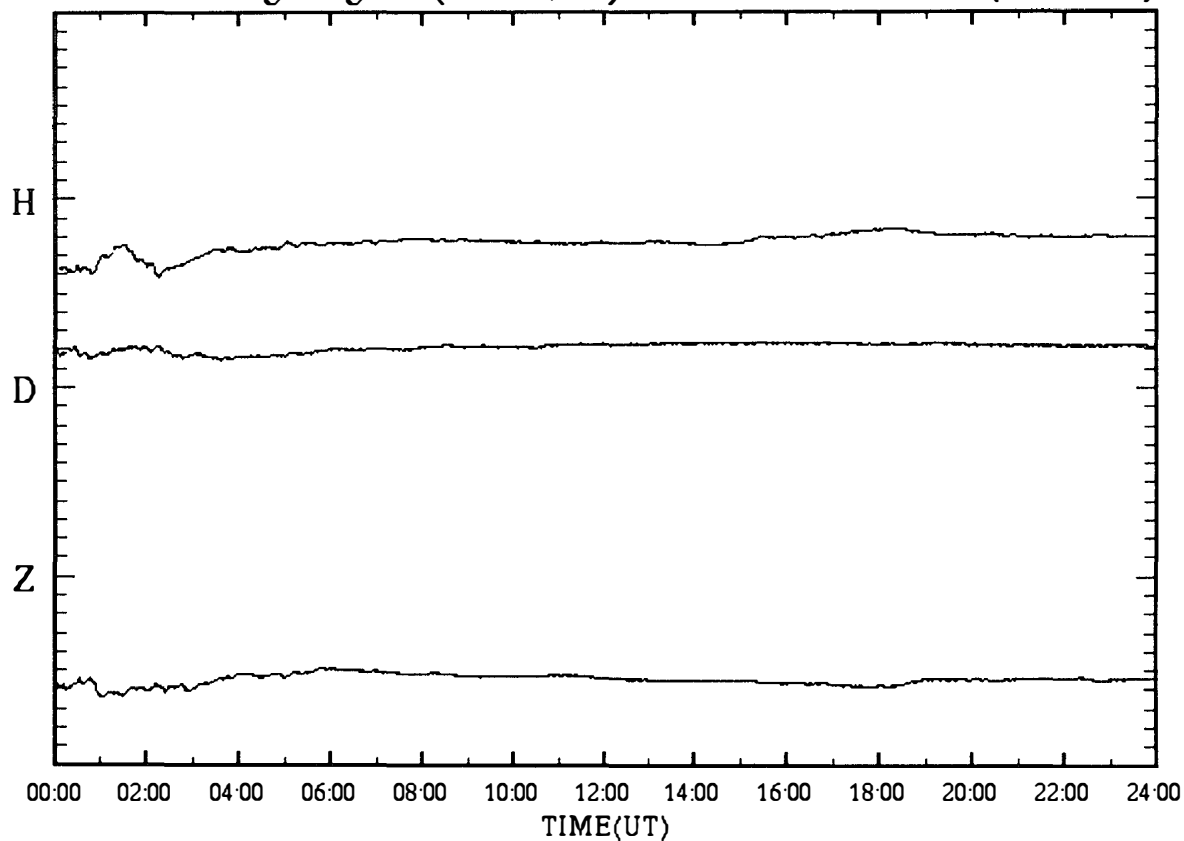

SYOWA magnetogram (100 nT/div)

25 Dec.1997 (DAY:359)

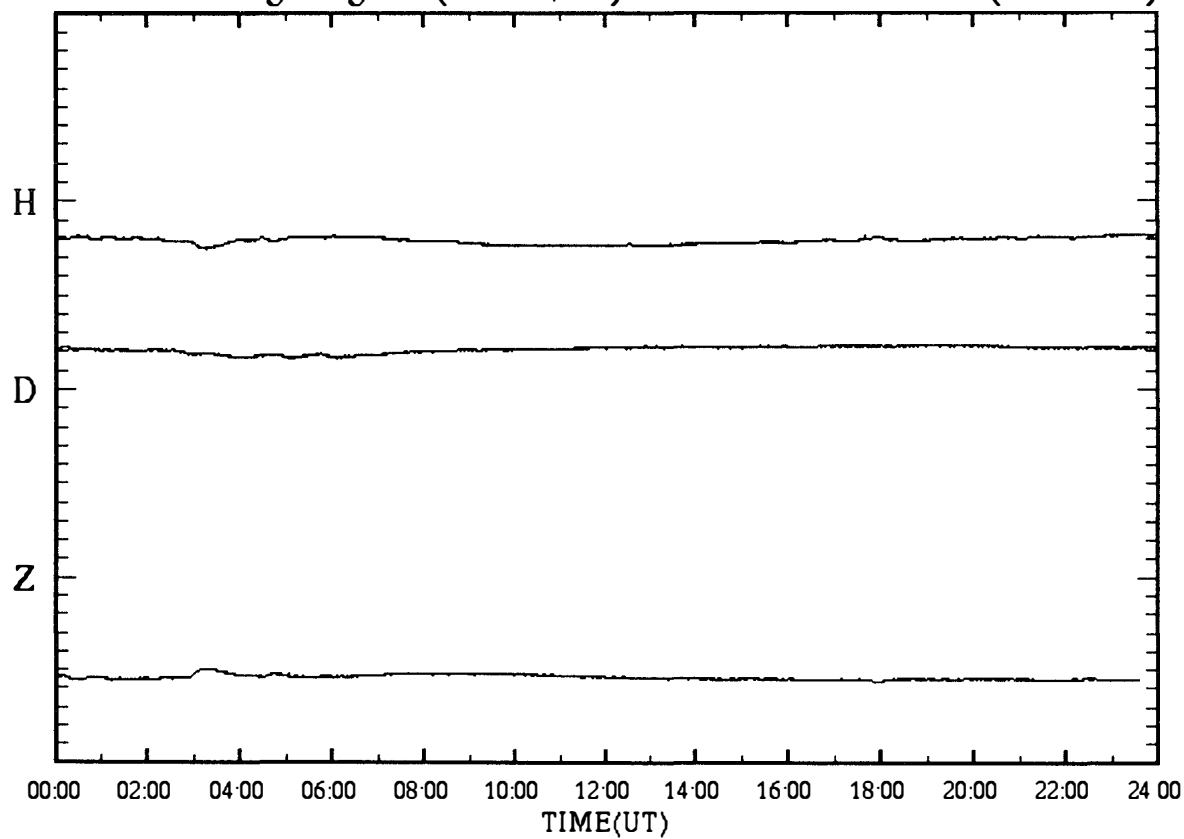

SYOWA magnetogram (100 nT/div)

26 Dec.1997 (DAY:360)

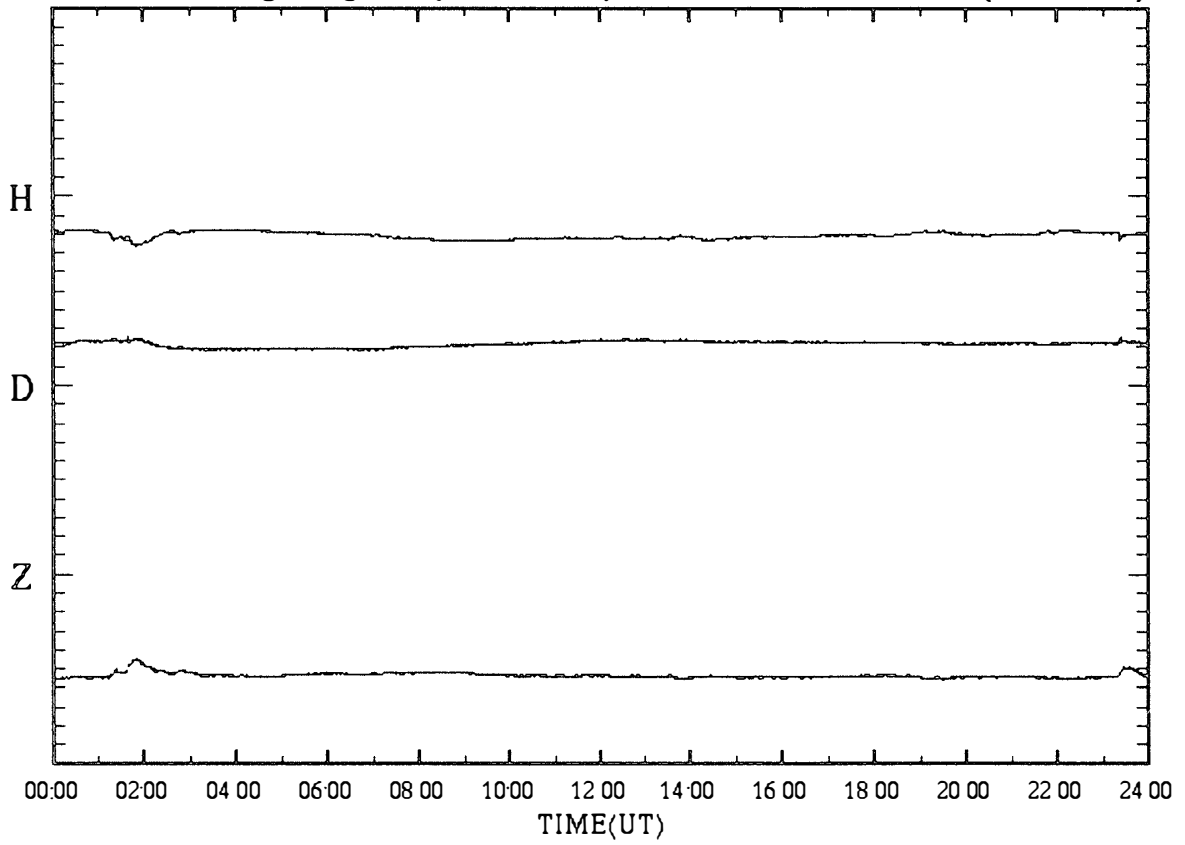

SYOWA magnetogram (100 nT/div)

27 Dec.1997 (DAY:361)

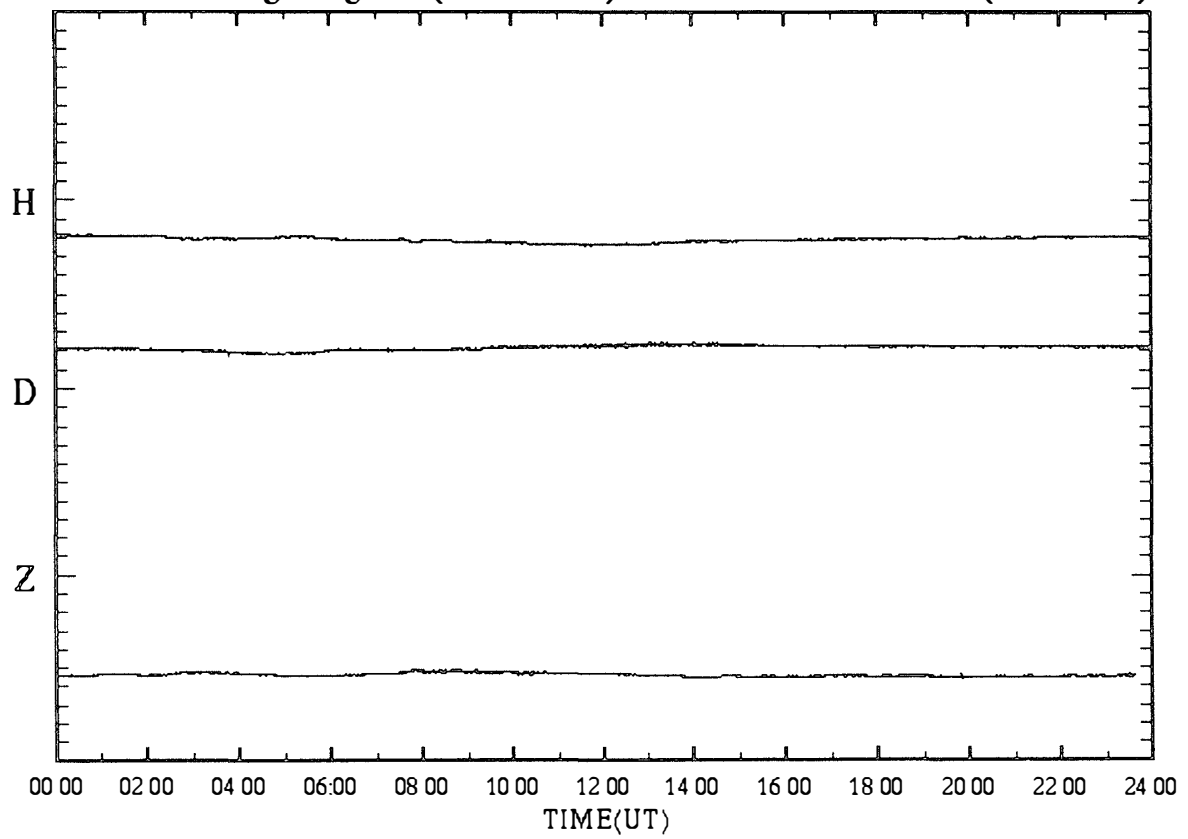

SYOWA magnetogram (100 nT/div)

28 Dec.1997 (DAY:362)

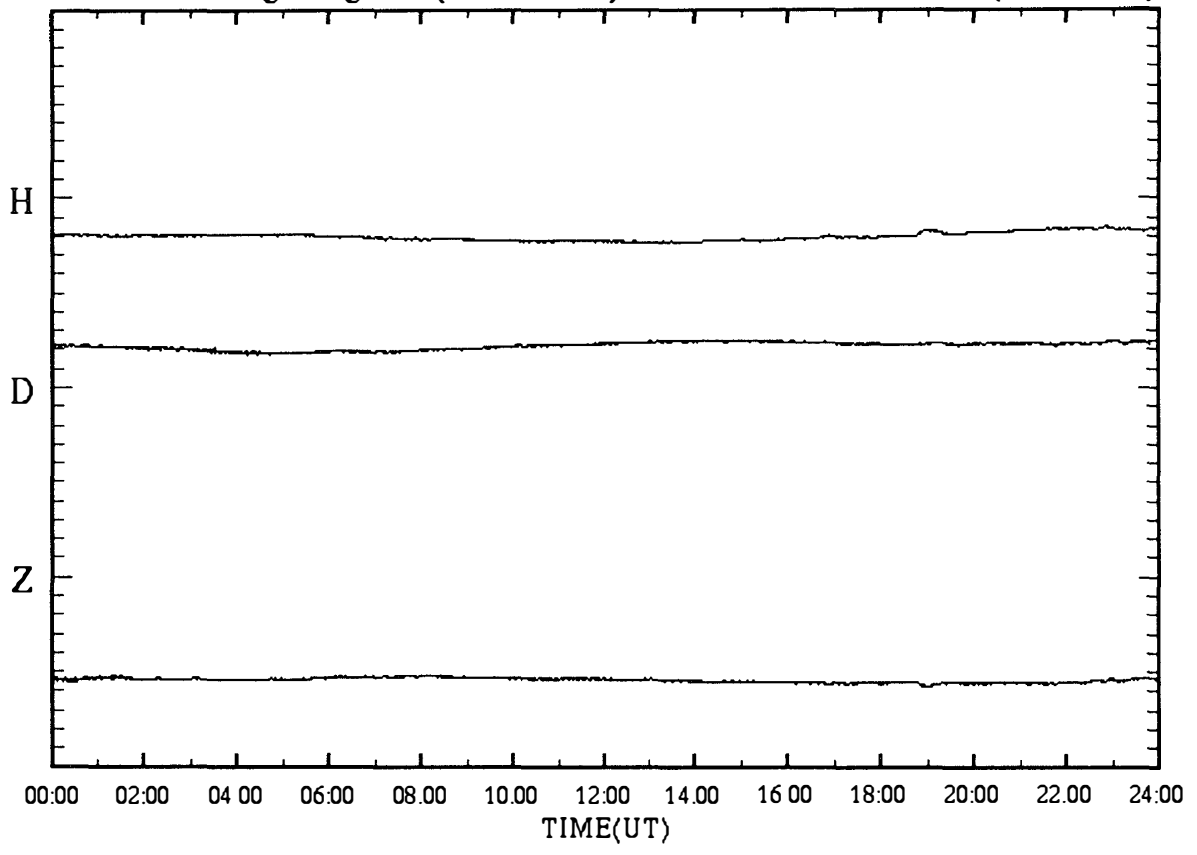

SYOWA magnetogram (100 nT/div)

29 Dec.1997 (DAY:363)

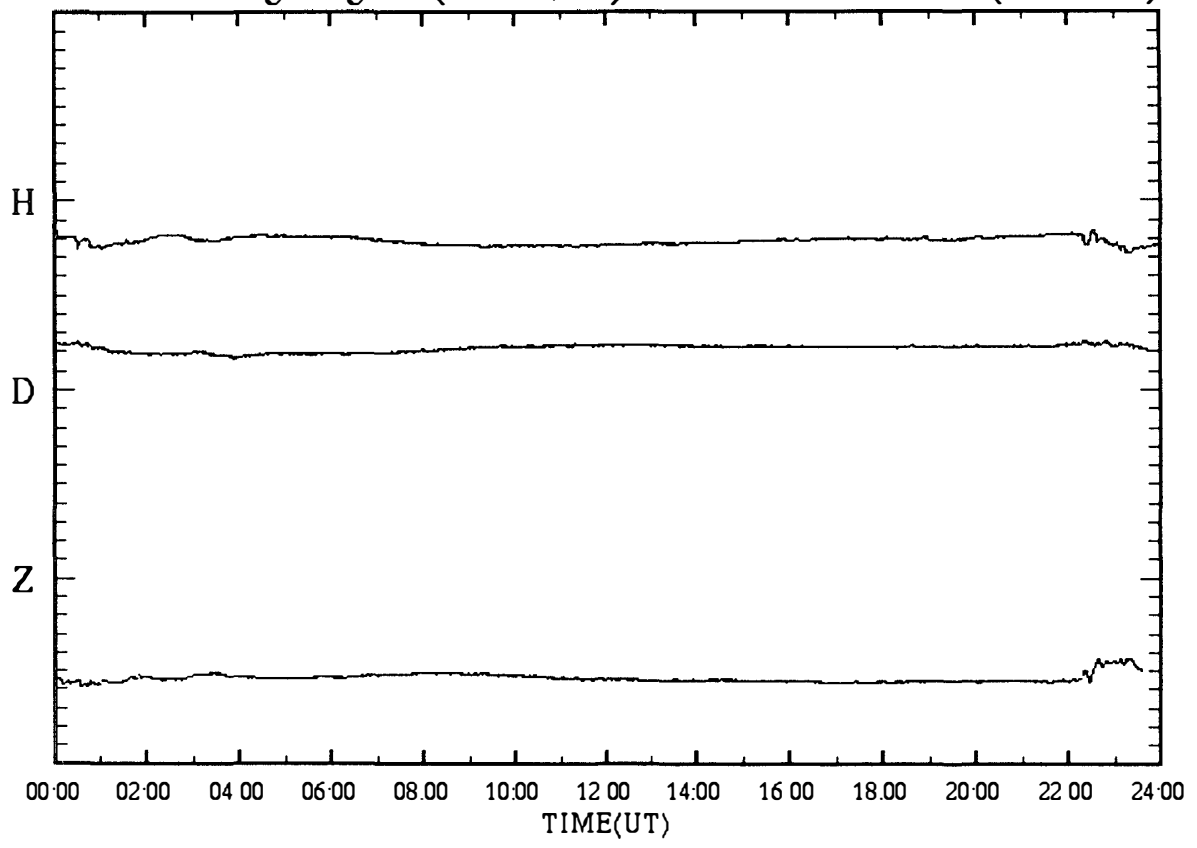

SYOWA magnetogram (100 nT/div)

30 Dec.1997 (DAY:364)

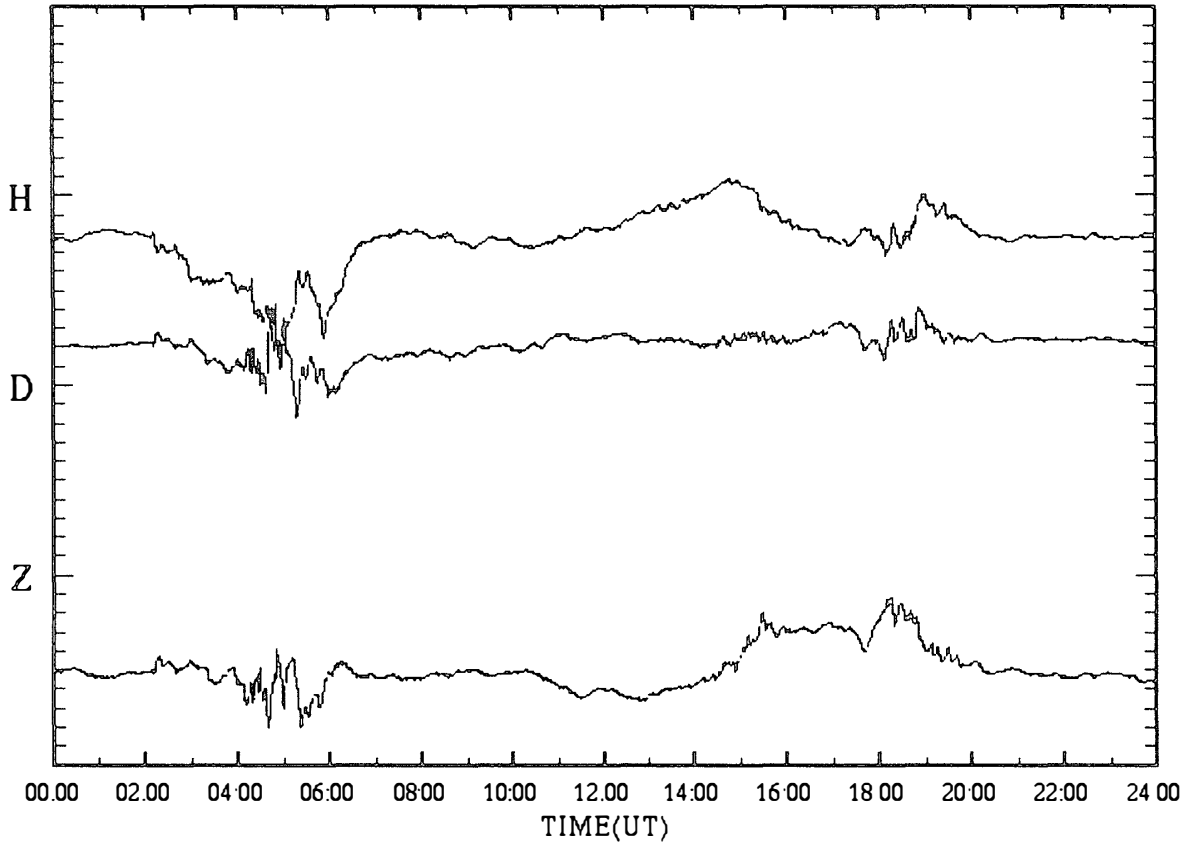

SYOWA magnetogram (100 nT/div)

31 Dec.1997 (DAY:365)

