

Preliminary study of the transition of sea ice during the melting process

Shinsuke Kojima^{1*}, Toshiyuki Kawamura² and Hiroyuki Enomoto¹

¹*Kitami Institute of Technology, 165, Koencho, Kitami 090-8507*

²*Institute of Low Temperature Science, Hokkaido University,
Kita-19, Nishi-8, Kita-ku, Sapporo 060-0819*

*Corresponding author. E-mail: dse03003@std.kitami-it.ac.jp

(Received March 9, 2005; Accepted September 12, 2005)

Abstract: In order to understand the transition in sea ice, snow transformation, and temperature variations, we carried out tank experiments in a cold room. In the melting experiment of bare ice, the transition of the condition of the ice surface was observed through visual observations and reflectance measurements. The first change was manifested in the surface becoming wet and acquiring a rough texture. Subsequently, a porous layer was formed under the ice surface. Since this layer scattered the incident light, it appeared as a bright surface. The reflectance of this surface was high as compared with that measured during the initial stages of melting. However, this thin scattering layer disappeared as the melting progressed. As a result, the reflectance was reduced to its value during the initial stage of melting. In the melting experiments on snow covered sea ice, the structure of snow-ice became porous and mechanically weak before the thickness reduction commenced. The temperature gradients of bare ice and snow covered ice were small during the melting process compared to those during the growth period.

key words: melting experiment, sea ice transition, porous layer, temperature variation, snow transformation

1. Introduction

The decay of sea ice involves complex mechanisms because the heat of fusion is used not only for effecting a reduction in thickness but also for forming a porous structure. Snow transformation on sea ice exhibits various processes as snow on sea ice has always transformed. Although there have been a few experimental studies and field observations on sea ice decay and snow transformation (e.g., Shokr and Barber, 1994; Kawamura *et al.*, 1997; Haas *et al.*, 2001; Massom *et al.*, 2001), the processes involved in sea ice are not yet clear.

In previous studies of sea ice decay, Toyota *et al.* (2000) carried out ship observations in early February 1996 and 1997 in the Sea of Okhotsk. They confirmed that surface melting can occur in the daytime due to solar radiation even during the growth period. This suggests that sea ice melting occurs frequently in the Sea of Okhotsk. A

water tank experiment can provide an ideal alternative to field studies because of the stable experimental environment. Tison *et al.* (2002) carried out a tank experiment on the growth–melt–re-growth cycle on bare ice. They observed vertical temperature profiles in sea ice during the experiment. During the growth period, strong temperature gradients existed. The temperature gradients became quasi-isothermal during the melting period, but strong gradients were reestablished during the re-growth period. We carried out growth–melt experiments on snow covered ice as well as on bare ice. We observed the temperature variations and compared them with Tison’s results.

In this study, we specifically observed the transition of the surface conditions of bare ice during the melting period. The surface transition in sea ice is the key factor for understanding the heat exchange between sea ice and the atmosphere. The surface transition also affects satellite observations. This study has focused on the basic condition of ice. We also investigated the temperature variations in bare ice and in snow covered ice. While studying the processes of snow transformation, it was observed that the temperature variations in sea ice are influenced by the snow.

2. Experiment

Figure 1 is a schematic diagram of our apparatus. The water tank is constructed from a 15 mm-thick plate of clear acrylic plastic. Its inner dimensions are 800×800 mm and it is 600 mm in height. We filled the water tank with a 32‰ NaCl solution, which has a freezing temperature of -1.8°C . The water depth was maintained at 500 mm in all the experiments. Artificial sea ice was produced using this water tank. All

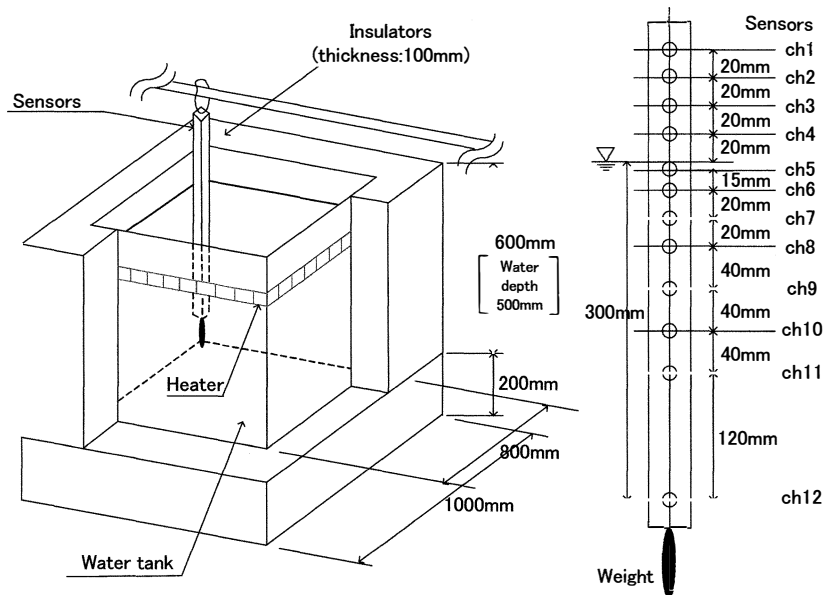

Fig. 1. A schematic diagram of the apparatus. For simplicity, the stirrer and data loggers are not shown. The sensor for measurement of room temperature is also not shown.

the sidewalls and the bottom of the water tank were lined with 100 mm and 200 mm thick insulators, respectively, in order to prevent ice formation on them. Belt-shaped heaters of 50 mm width were set around the sidewalls at the level of the water surface to prevent the growing sea ice from adhering to the walls. Thus, the produced sea ice remains floating inside the water tank. Measurements of sea ice thickness were performed from the side of the tank. A part of the insulator is removable. The color of the inner surface of the insulators is black so as to enable accurate measurements of the sea ice thickness. In order to carry out continuous measurements of temperature, 13 platinum resistance thermometers were placed at the corners of the tank. The temperature was measured at intervals of 10 min.

The experiment involving the cycle of growth and melting was repeated eight times (Table 1). During the experiment, the entire apparatus was placed in a cold room at a temperature of -20°C . Although there were temperature fluctuations due to the performance of the cooling system and the defroster in the cold room (Table 1), the increase in room temperature caused by the defroster did not affect the experiment because this increase occurred only at 12 h intervals and continued for less than 30 min. The maximum room temperature recorded was -12°C . The ice thickness was measured just prior to melting (Table 1).

In all the experiments except experiments 1 and 8 (Table 1), we mixed the water with a stirrer in order to produce uniform salinity and facilitate the formation of a granular layer in the sea ice. Another objective of the mixing was to enable comparison of different types of melting phenomena that arise due to variations in the structure of sea ice. In experiments 2, 3, and 4, the entire structure of sea ice was composed of granular ice on account of the continuous mixing. We confirmed this in the previous experiment under the same conditions. In experiments 5, 6, and 7, the upper structure comprised granular ice, while the adjacent layer comprised columnar ice. This occurred due to cessation of mixing at the point when the granular layer grew to 3 cm. If the mixing was not performed during the sea ice growth, as in experiments 1 and 8 (Table 1), we can produce a structure composed entirely of columnar ice (Kawamura *et al.*, 2004). During the melting period in experiments 2, 3, and 4, there was a turbulent flow under the ice. We tried to observe the manner in which the turbulent flow affected the melting of sea ice. In experiments 4 and 5, we rapidly increased the room temperature to $+5.5^{\circ}\text{C} \pm 1^{\circ}\text{C}$ within a short period (approximately 7 h) to facilitate rapid melting. The melting processes in these cases were approximately 8 to 14 h faster than those in the other experiments. The purpose of these two cases was to compare the effect of the melting rate on the sea ice melting process.

We also measured the reflectance of the surface of bare ice under five different conditions to observe the transition using a spectrometer (Ocean Optics Inc., PS-1000). The reflectance measurement was repeated three times using a white plate as a reference. The distance between the sensor and the bare sea ice surface was approximately 15 cm. A halogen lamp was used as the light source. However, the effect of the white plate is ignored in this paper because we used relative reflectance. The maximal value of reflectance prior to the onset of melting was assumed to be 1 and the reflectance was defined as standard. The trend of the surface condition transition was determined using the reflectance variations.

Table 1. Summary of the experiment.

No.	Mixing	Snow	Room temp. (growth) °C	Room temp. (melt) °C	Ice thickness cm	Bright surface* hour	Dark surface** hour	Remarks
1	No	No	-17.0±2	+7.0±2	19	17.2	23.9	No mixing
2	Yes	No	-17.0±2	+7.0±2	19	19.7	29.7	Mixing was continued until the end of the experiment.
3	Yes	No	-17.0±2	+7.0±2	16	16.9	24.3	Mixing was continued until the end of the experiment.
4	Yes	No	-17.0±2	+5.5±1	18	7.4	20.5	Mixing was continued until the end of the experiment.
5	Yes	No	-17.0±2	+5.5±1	12	7.0	17.0	Mixing was stopped when sea ice thickness became 3 cm.
6	Yes	No	-17.0±2	+6.0±1	10	15.3	29.0	Mixing was stopped when sea ice thickness became 3 cm.
7	Yes	Yes	-17.0±2	+7.5±2	8	21.2	—	Mixing was stopped when sea ice thickness became 3 cm.
8	No	Yes	-17.0±2	+6.0±2	8.5	20.8	—	No mixing

*: Bright surface corresponds to B in Figs. 2, 3, 4, 5 and E in Figs. 6, 7.

** : Dark surface corresponds to C in Figs. 2, 3, 4, 5.

In experiments 7 and 8, the effect of snow cover on sea ice was investigated. The snow was collected in the winter season and was preserved in a cold room. Its density was 200 kg m^{-3} and its temperature was approximately -20°C . In order to produce snow covered sea ice, we created artificial snowfall. We used a snow-filled vessel and shook it to disseminate snow on the sea ice from a height of 50 cm. The artificial snowfall produced a 10 cm-thick snow cover on the 6 cm-thick sea ice in 30 min.

3. Results and discussion

3.1. Bare ice

The bare ice melting experiment was repeated six times. The transition of the surface conditions was observed by visual observations and reflectance measurements (rows 1 to 6 in Table 1).

3.1.1. Surface conditions

Figure 2 shows photographs of the surface transition in bare ice. A, B, and C correspond to A, B, and C in Figs. 3, 4, and 5.

During the bare ice melting experiment, the ice surface initially became wet and rough. Next, a porous layer was formed under the surface. The thickness of this layer was approximately 1 cm. Its formation was observed in all of the experiments. Owing to the porous structure, light was scattered in the layer. Thus, the layer appeared as a bright surface. Regardless of the melting rate, the ice surface became rough and wet. Moreover, a thin scattering layer was also formed. The bright surface was replaced by a dark one after several hours because the scattering layer vanished as melting progressed. With regard to the effect of mixing, we did not observe any difference in melting of the different sea ice structures. In Table 1, values for bright

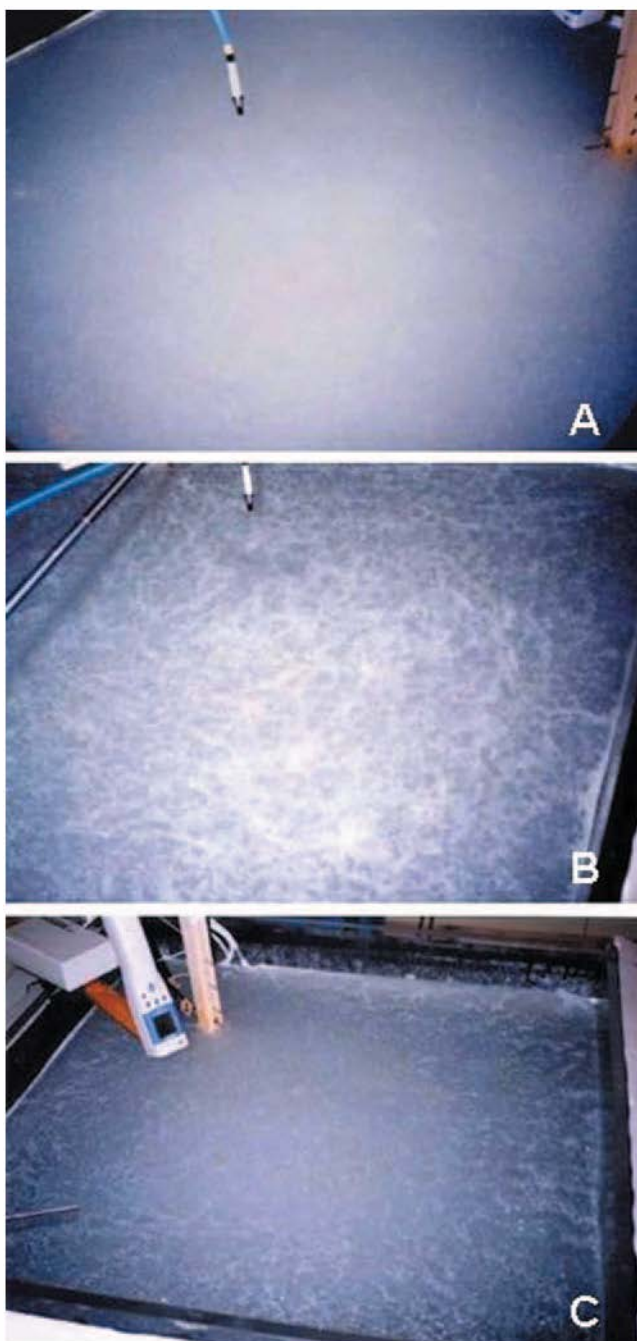
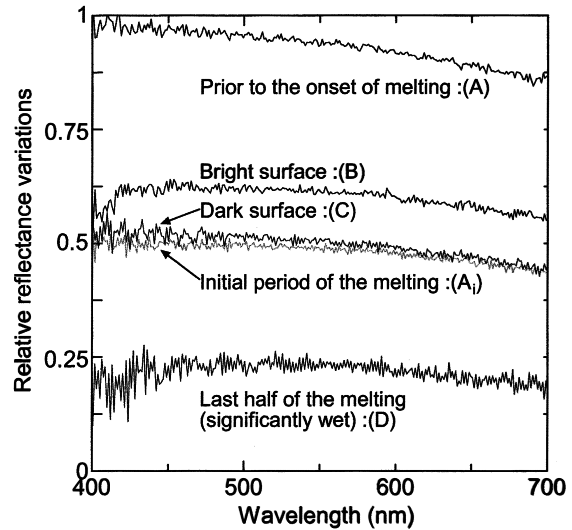

Fig. 2. Typical photographs of the surface condition of (A) before the onset of melting, (B) bright surface, and (C) dark surface on bare ice. These letters correspond to indications in Figs. 3, 4, and 5. Detailed information on the bright and dark surface is provided in the explanation of Table 1.

Fig. 3. Temporal variation of reflectance measured on five different surface types. Measurement was done from (A), (A_i), (B), (C) to (D). Note that reflectance increased from (A_i) to (B), then decreased again. The sea ice thickness was around 13–16 cm. Before the onset of melting (A) had a dry surface; and other stages had have wet surface. The room temperature in this measurement is given in Table 1.



and dark surfaces indicate the time taken for the formation of such a surface condition. The time taken for the formation of the bright surface was recorded after the room temperature reached 0°C while that for the dark surface was recorded after the appearance of the bright surface.

Figure 3 shows the reflectance variations. The reflectance decreased immediately after the onset of melting because the sea ice surface became wet (A_i). However, when the bright surface appeared, the reflectance increased in comparison to its value at the start of melting (B). As the melting progressed, a dark surface was formed and the reflectance decreased again (C). During the last half of the melting period, the reflectance was significantly reduced (D). These variations in reflectance were measured consistently in all of the bare ice experiments.

Since a porous layer was formed along with an inner cavity, there is a thin ice plate at the surface of the porous layer. Thus, a cavity exists between the thin ice plate and the sea ice. The thickness of the ice plate and the depth of the cavity were approximately 0.2 and 0.8 cm, respectively. The salinity of the thin ice plate was 1‰. The existence of a surface layer with nearly pure ice structure is suggested by the experimental results of Knight (1962). It is considered that the phenomena contribute to the formation of a porous layer. The detailed mechanism of formation of the porous layer is clearer from a thermal perspective, so we will return to this topic in the following section.

3.1.2. Temperature variations

Figures 4 and 5 show typical results for the case of bare ice. Figure 4 shows the temperature variation and Fig. 5 shows vertical temperature profiles. The results correspond to experiment 5 (Table 1).

In experiment 5, there were large temperature differences between the sensors during the growth period. Sea ice growth was allowed to continue until a thickness of 12 cm was attained. Subsequently, we commenced the melting experiment. The ice

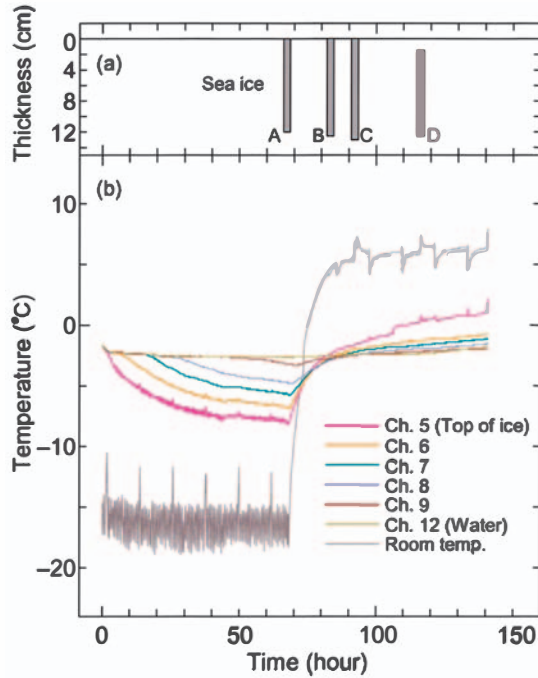

Fig. 4. Temporal variations of (a) sea ice thickness and (b) temperature profiles on bare ice. A thickness of 0cm indicates the initial surface of sea ice measured by a sensor in the surface layer of the sea ice. The sea ice surface of D is 1.5cm lower than the others, because melting progressed from the surface in our experiment. Detailed information on the sensors is given in Fig. 1. This figure corresponds to Fig. 5.

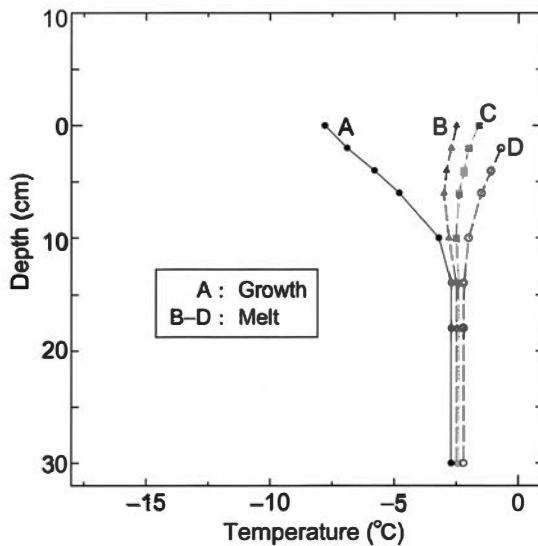

Fig. 5. Vertical temperature profiles of bare ice. The temperature variations were shifted alphabetically. These letters correspond to the indications in Figs. 2, 3, and 4. The surface temperature of D is not available because sensor was exposed by the progress of melting.

temperature was increased rapidly and became almost same because of warming from the surface (Fig. 4). After about 100 h, the sensor at the top of the sea ice was exposed as a result of surface melting. On the other hand, the temperature gradients became small after the onset of melting (Fig. 5). Vertical temperature profiles of sea ice during the melting period were observed through both tank experiments (Tison *et al.*, 2002) and field observations. Shokr and Barber (1994) carried out observations of first-year ice and multiyear ice in the Arctic Ocean during the melting period. The vertical temperature profiles indicated that the temperature gradients become quite small for both ice types, regardless of the ice thickness. Tison's results show the same variation of the temperature gradients.

During the melting period, we observed three sea ice formation features: (1) formation of porous layer; (2) delay of reduction of the thickness; (3) continuing growth of sea ice after onset of melting. These phenomena appear to be attributable to the effect of brine pockets as thermal buffers (Maykut and Untersteiner, 1971). With regards to them, we observed the following.

First, the porous layer was formed when the temperature gradient became significantly small (B in Figs. 2 and 5). The mechanism can be explained from the viewpoint of temperature gradients. In temperature gradient B in Fig. 5, the directions of the heat flux at the surface and bottom were downward and upward, respectively. The heat flux stagnated in sea ice and created cavities. Although this internal melting might be expected to accelerate the vertical brine drainage, there was only a little drainage in the surface layer of sea ice because the temperature was still cold. Due to the brine drainage, a porous layer appeared at the sea ice surface. However, the direction of the heat flux changed to uniformly downward with the progress of melting (C in Fig. 5). The thin ice plate disappeared due to this downward heat flow from the atmosphere. Thus, the porous layer, and consequently the bright surface, disappeared and were replaced by a dark surface (C in Fig. 2).

Second, the reduction of sea ice thickness did not commence immediately after the room temperature reached 0°C. However, a surface transition and a drastic change in sea ice temperature profiles appeared after the onset of melting. Thus, the available heat appears to be used to alter the thermal conditions of the sea ice before effecting a reduction in thickness. The changing thermal conditions of sea ice might cause variations in the brine volume. Increase of brine volume would cause a delay in reduction of the thickness.

Third, in the present study the sea ice grew 0.5 cm in the downward direction even after the onset of surface melting because the temperature gradient of the growth period persisted due to the brine thermal buffer (B and C in Figs. 4a and 5). The bottom of the sea ice began to melt 41 h after a room temperature of 0°C was reached (D in Fig. 4). This continuous growth and time lag in sea ice decay possibly indicates the role of brine pockets as thermal buffers.

3.2. Snow covered ice

Experiments 7 and 8 involve snow covered ice (Table 1). In Table 1, the bright surface indicates the time elapsed until the formation of porous snow-ice. Incidentally, the surface of the snow covered sea ice did not become dark because brittle snow-ice

persisted on the sea ice until the end of the experiment.

3.2.1. Surface conditions

Due to the load of the snow on the sea ice, the ice was forced down and submerged. The entire snow cover on the ice was converted into slush. The average thickness of the slush was 9 cm. However, the slush refroze several hours later and formed snow-ice. The average density and thickness of this snow-ice were 650 kg m^{-3} and 7 cm, respectively. However, the snow-ice became porous and mechanically weak as melting progressed. The weakening of the snow-ice suggests that the melting of snow-ice commences with alteration of its inner structure.

3.2.2. Temperature variations

We remark on the relationship between temperature and time, and the vertical temperature gradients. Typical results are indicated in Figs. 6 and 7, respectively.

In Fig. 6, the sea ice temperature increased immediately and became almost same after the snowfall. Next, the temperature of the sea ice and snow decreased. After the onset of melting, the sea ice temperature increased and became almost same as seen in the bare ice experiments. However, the temperature of snow covered ice increased slower than that of bare ice. In the present experiment, melting progressed from the surface downward. Therefore, several sensors near the surface of the ice were exposed after some time. Other studies have also revealed similar temperature variations. Takizawa and Wakatsuchi (1982) conducted a field experiment in a lagoon during the growth period of the ice. Their results indicated that sea ice becomes warm during snowfall, but its temperature is reduced due to slush formation. The temperature increased and became almost same when the air temperature rose to almost 0°C in the daytime. These temperature variations are consistent with our results. We consider the temperature variations in snow covered ice during the growth and melting periods as important parameters because these data have contributed understanding of the mechanism of the melting of snow covered ice.

The relationship between snow transformation and variations in its temperature was observed. A typical result is shown in Fig. 7. The temperature gradients in snow on sea ice exhibited drastic variations compared with those within the sea ice. Immediately after loading snow on sea ice, the temperature gradient was observed to be significantly large (B). Although the gradient decreased significantly due to slush formation (C), it once again became steep owing to snow-ice formation (D). During the melting period, the gradients became slightly positive (E and F). The dependence of temperature profiles on the behavior of the sea ice temperature variations and snow transformation has also been observed in the Antarctic (Haas *et al.*, 2001). Their results, especially the temperature profiles of snow and sea ice, are similar to ours. However, the structure of snow in their study was more complex than that in our study because their snow cover was not completely altered by submergence and was composed of several layers. Several different snow properties affect the heat exchange between water and the atmosphere through the ice. Therefore, it is necessary to investigate the effects of different types of snow on the thermal variation of sea ice in greater detail.

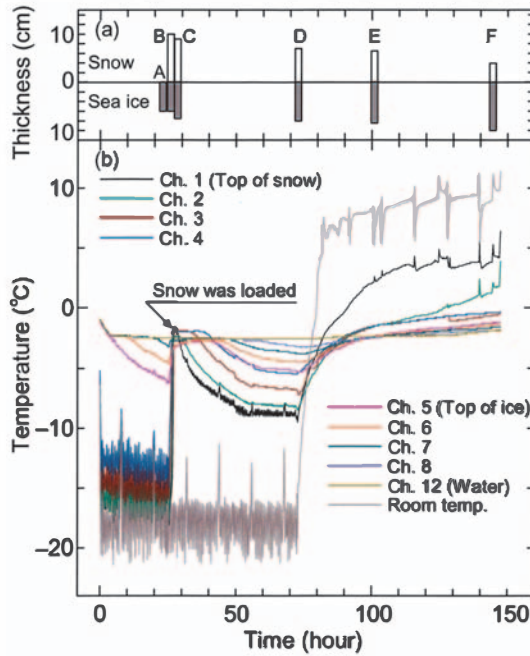

Fig. 6. Same as Fig. 4, but for snow covered condition. Temporal variations of (a) snow depth and sea ice thickness and (b) temperature on snow covered ice. Detailed information on the sensors is given in Fig. 1. Sensors Ch. 1, 2, 3, and 4 measured room temperature until the loading of snow on sea ice. This figure corresponds to Fig. 7.

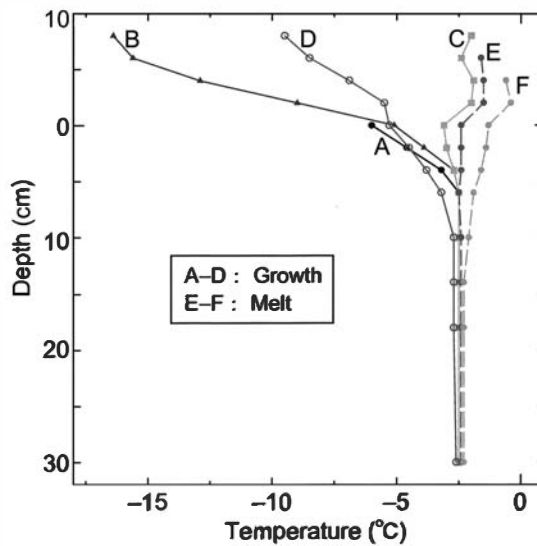

Fig. 7. Same as Fig. 5, but for snow covered condition. Vertical temperature profiles of snow covered ice. The temperature variations were shifted alphabetically. These alphabets correspond to Fig. 6. The surface temperature of E and F is lacked because sensors were exposed due to progress of melt.

4. Conclusions

We carried out melting experiments on bare ice and snow covered sea ice in a water tank in order to understand the mechanism of transition of surface conditions, transformation of snow, and temperature variations. The results are summarized below:

In the bare ice experiment, we observed transition of the surface condition during the melting period through visual observations and reflectance measurements. After the onset of melting, the surface initially became wet and rough. Subsequently, a porous layer was formed under the surface with a thickness of approximately 1 cm. Since the structure was porous, light was scattered in the layer. Thus, the layer appeared as a bright surface. Although the reflectance was reduced once, during the initial period of melting, it increased later due to the appearance of the bright surface. When the surface condition transition occurred, the sea ice temperature exhibited a large change. The surface transition and temperature profiles suggest that the heat of fusion is used for creating a porous structure prior to the thickness reduction.

The snow on the sea ice underwent a complex transformation, and its temperature variations were drastically different from those of the sea ice. After the onset of melting, as seen in the bare ice experiments, the sea ice temperature increased and became almost same. However, the temperature of snow covered ice increased slower than that of bare ice. The temperature gradients of the snow-ice were significantly reduced. Thickness reduction of snow-ice is expected to commence after alteration of the inner structure because snow-ice becomes porous and mechanically weak before its thickness decreases.

Acknowledgments

We would like to thank S. Takahashi, T. Kameda, K. Tateyama, and T. Tanikawa for their encouragement and useful discussion. We also appreciate valuable and thorough comments by two anonymous reviewers. Several experiments were assisted by T. Hori. This research was supported in part by the Sasakawa Scientific Research Grant from The Japan Science Society.

References

- Haas, C., Thomas, D.N. and Bareiss, J. (2001): Surface properties and processes of perennial Antarctic sea ice in summer. *J. Glaciol.*, **47**, 613–625.
- Kawamura, T., Ohshima, K.I., Takizawa, T. and Ushio, S. (1997): Physical, structure, and isotopic characteristics and growth processes of fast sea ice in Lützw-Holm Bay, Antarctica. *J. Geophys. Res.*, **102**, 3345–3355.
- Kawamura, T., Matsubaya, O., Sato, A. and Kamata, Y. (2004): An experimental study on snow and superimposed ice formation on sea ice. *Proc. 17th IAHR Symp. on Ice, Saint Petersburg, Russia*, 258–267.
- Knight, C.A. (1962): Curved growth of ice on surfaces. *J. Appl. Phys.*, **33**, 1808–1815.
- Massom, R.A., Eicken, H., Hass, C., Jeffries, M.O., Drinkwater, M.R., Sturm, M., Worby, A.P., Wu, X., Lytle, V.I., Ushio, S., Morris, K., Reid, P.A., Warren, S.G. and Allison, I. (2001): Snow on Antarctic sea ice. *Rev. Geophys.*, **39**, 413–445.
- Maykut, G.A. and Untersteiner, N. (1971): Some results from a time-dependent thermodynamic model of sea

- ice. *J. Geophys. Res.*, **76**, 1550–1575.
- Shokr, M.E. and Barber, D.G. (1994): Temporal evolution of physical and dielectric properties of sea ice and snow during the early melt season: observation from SIMS '90 experiment. *J. Glaciol.*, **40**, 16–30.
- Takizawa, T. and Wakatsuchi, M. (1982): Snow layer on sea ice. *Low Temp. Sci., Ser. A*, **41**, 159–165 (in Japanese with English abstract).
- Tison, J.L., Haas, C., Gowing, M.M., Sleewaegen, S. and Bernard, A. (2002): Tank study of physico-chemical controls on gas content and composition during growth of young sea ice. *J. Glaciol.*, **48**, 177–191.
- Toyota, T., Kawamura, T. and Wakatsuchi, M. (2000): Heat budget in the ice cover of the southern Okhotsk Sea derived from in-situ observations. *J. Meteorol. Soc. Jpn.*, **78**, 585–596.