

## BOREHOLE DRILLING FOR SEWAGE DISPOSAL AT ASUKA STATION, EAST ANTARCTICA

Kenji ISHIZAWA<sup>1</sup> and Akiyoshi TAKAHASHI<sup>2</sup>

<sup>1</sup>*National Institute of Polar Research, 9-10, Kaga 1-chome, Itabashi-ku, Tokyo 173*

<sup>2</sup>*Geo Tec Co. Ltd., 29, Shirakabe 4-chome, Higashi-ku, Nagoya 461*

**Abstract:** A borehole for sewage disposal was drilled at Asuka Station (71°31'34"S, 24°08'17"E, 930 m a.s.l.) in January 1987. The borehole, 400 mm in diameter and 27.5 m in depth, was drilled 50 m distant from the main hut using a steam drilling system. The drilling speed was 4 m/h between the snow surface and 20 m depth. The total amount of kerosene used for melting snow and steam generation was 110 l.

Sewage stored in the tank was directed to the borehole through a heated pipe. The cumulative amount of sewage was 1077 kl for 5 years, and the bottom of the hole rose 14 m.

### 1. Introduction

Sewage disposal for a station on the snow surface was a big problem when we made plans for Asuka Station. The sewage at Mizuho Station, operated during the period from 1970 to 1986, was dumped into cracks which developed in the snow. We experienced many troubles because the cracks were filled with sewage (YONEZAWA *et al.*, 1980).

At camps on the snow surface in Greenland the sewage was diffused into the firn, and the method was successful (SCHMITT and RODRIGUES, 1963). We planned to saturate the pores of the firn with sewage by drilling a deep hole into the firn.

The depth of the boundary between snow/firn and ice is thought to be within 50 m of the surface at Asuka Station. The average porosity of the snow/firn is calculated as 35% if the average density is 600 kg/m<sup>3</sup>. In order to use the firn pore efficiently, a borehole should be excavated down to the boundary. Figure 1 shows an image of firn saturated with sewage. Diffused sewage penetrates through the firn and freezes. Consequently, the bottom of the borehole will gradually rise with time.

### 2. The Location and Climate of Asuka Station

Asuka Station is located on the ice sheet near the Sør Rondane Mountains in Queen Maud Land as shown in Fig. 2. Figure 3 shows monthly mean air temperature, being the annual mean of -18.3°C.

### 3. Steam Drill

Steam and hot water drills were recommended as drilling systems for the borehole. A hot water drilling system needs much water; therefore we were afraid that the water might fill the firn pores. Consequently, a steam drill system was adopted. The Japanese

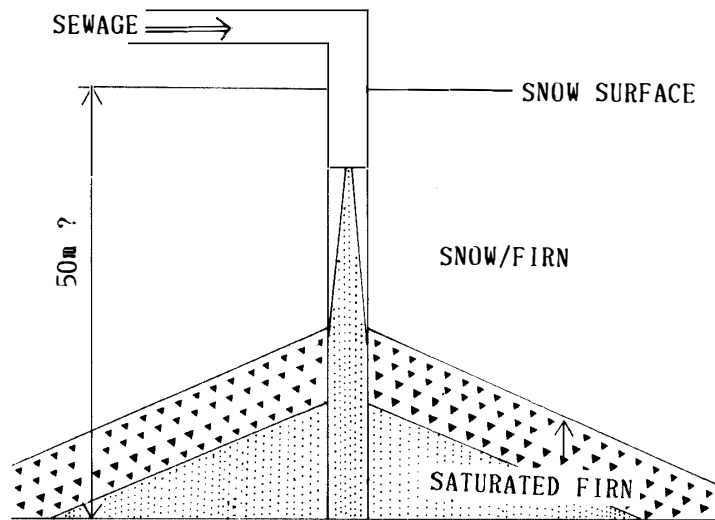

Fig. 1. An image of sewage in the snow.

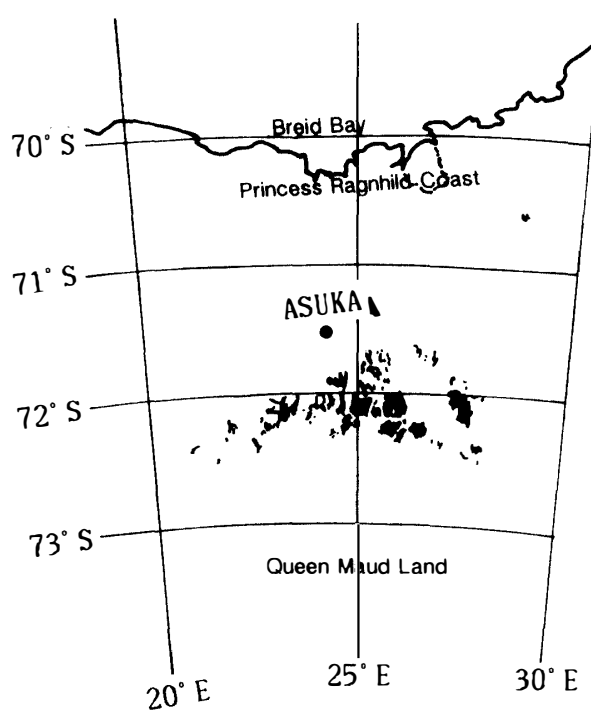

Fig. 2. Position of Asuka Station.

Antarctic Research Expedition used a small steam drill for snow temperature measurement (NARUSE and YOKOYAMA, 1975; NARUSE and SUZUKI, 1975; SATOW, 1977). That was the another reason that the steam drill was adopted. A new drill system was developed for this operation.

The steam drill consists of a snow melter, steam generator, hose reel and nozzle as shown in Fig. 4. First, water is made from snow by the snow melter, then the water is

changed to steam by the steam generator, finally steam sprayed from nozzles melts snow. The performance and specifications of the system are shown in Table 1.

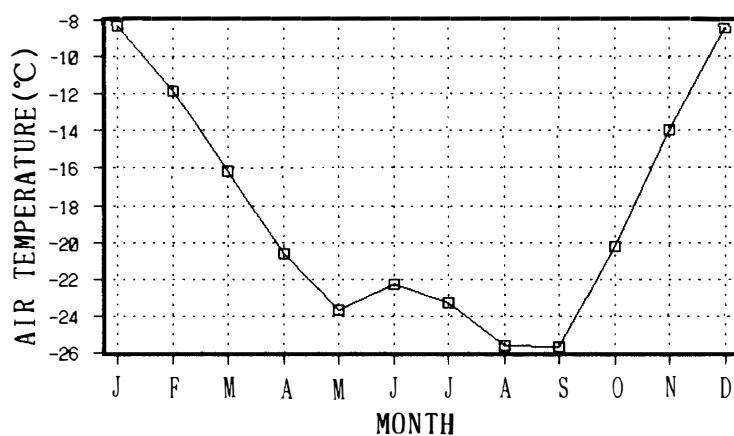

Fig. 3. Monthly mean air temperature at Asuka Station.

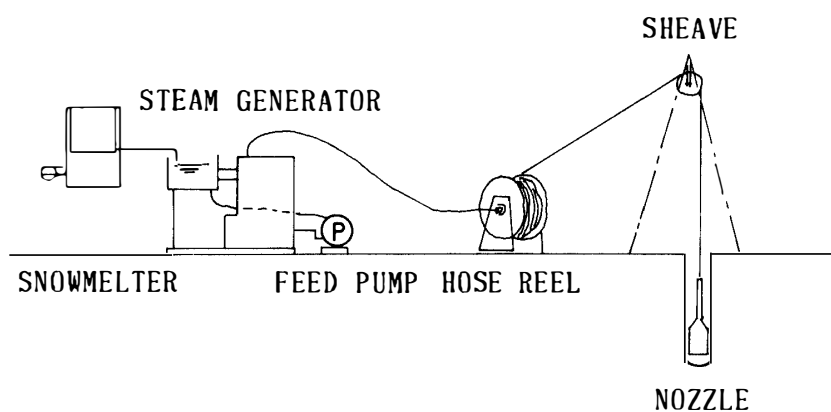

Fig. 4. Steam drilling system.

Table 1. Performance and specification of steam drilling system.

	Item	Specifications
Snow melter	Gun-type oil burner	Nozzle: 0.85 gal/h
Steam generator	Boiler Water supply pump Gun-type oil burner	Effective heat conduction area : 1.7 m <sup>2</sup> 0.4 kW; head: 90 m; flow rate: 320 l/h Nozzle: 1.35 gal/h
Hose, drilling speed control	Hose Hose reel Speed control	Wire braid hose, inner diameter: 19 mm Diameter: 700 mm 0-1 rpm adjustable DC moter
Nozzle	Skirt Nozzle	Diameter: 300 mm; length: 400 mm Diameter: 40 mm; brass, with 1 mm Diameter nozzles (19 nozzles)

Snow is put into the snow melter by hand, and water is supplied to the water tank of the steam generator (Fig. 5). Water in the tank is supplied to the steam generator automatically by a feed pump when the water level of the generator is lower than a set level. The steam pressure was set to 785 kPa (8 kgf/cm<sup>2</sup>), and the burner for steam generation stopped when the pressure reached 883 kPa (9 kgf/cm<sup>2</sup>). Moreover, a safety valve operates when the pressure rises above a certain level. The steam is fed to the nozzle through a hose which is lowered automatically by a low speed DC motor attached to a leg



*Fig. 5. Drilling work at Asuka Station.*



*Fig. 6. Nozzle lowering apparatus.*

of the tripod (Fig. 6). The lowering speed is manually set by judging whether the nozzle touches the bottom of the borehole or not.

The nozzle consists of a skirt and 19 small nozzles illustrated in Fig. 7.

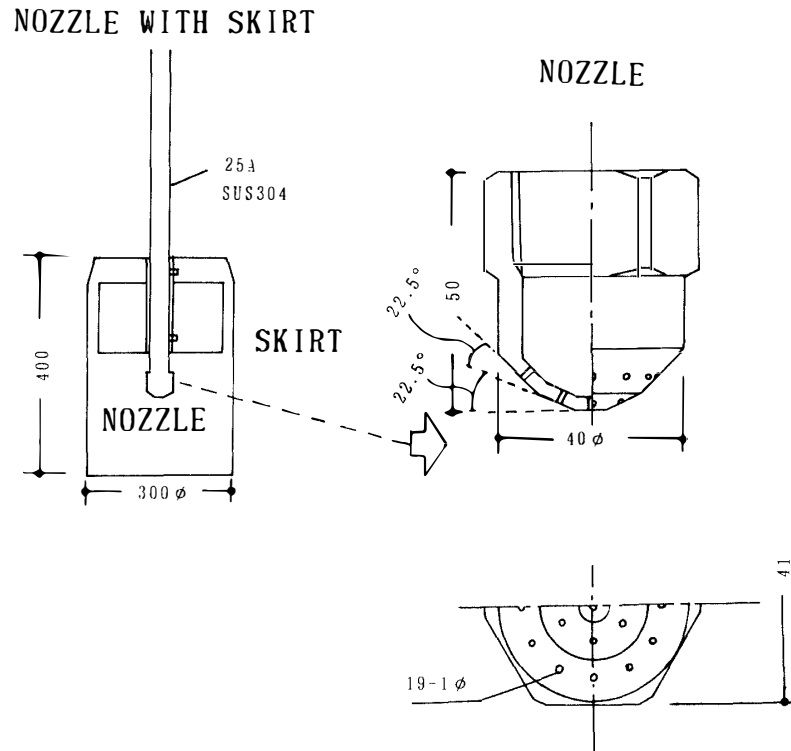

Fig. 7. Nozzle; (left) Nozzle with skirt. (right) Detail of the nozzle.

#### 4. Drilling at Asuka Station

The operation was carried out on February 9 in 1987, and steam was supplied for 9 hours. The lowering speed of the nozzle was 4 m/h between the snow surface and 20 m depth. Below about 20 m, the speed decreased gradually. The drilled depth was 27.5 m after 9 hours of operation, and the diameter was about 40 cm. The total amount of kerosene consumed by the snow melter and the steam generator was 110 l.

#### 5. Rise of the Borehole Bottom

The rise of the bottom was regularly measured by lowering a piece of string into the borehole. The relation between the hole's depth and amount of discharged sewage is shown in Fig. 8. The measurement was not carried out for the first 200 days, therefore, the line is drawn straight. The accumulative amount of sewage was 1077 kl, and the bottom rose 14 m over 5 years. The rising speed of the bottom decreased at shallow depth. The reason is because the porosity of firm increases at that depth.

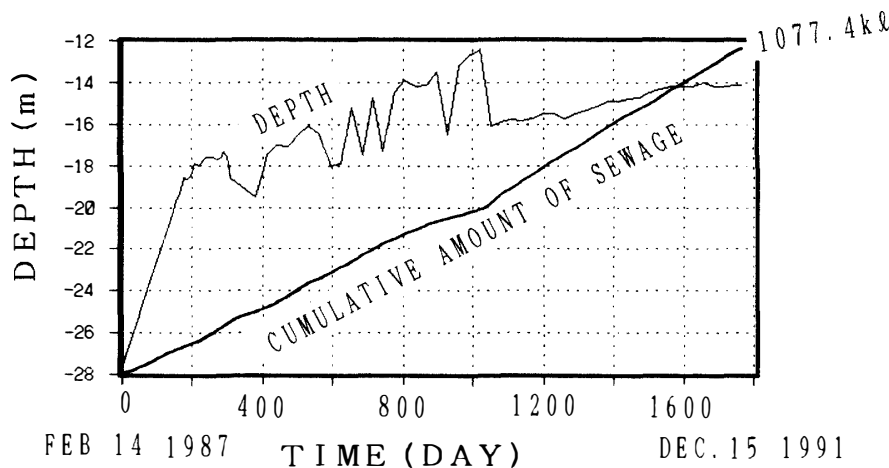

Fig. 8. Relation between hole's depth and amount of discharged sewage.

## 6. Concluding Remarks

The drilling operation for sewage disposal by steam drill was successfully performed, but the drilling system leaves some room for improvement. First, it is impossible to judge whether the nozzle reaches the bottom of the hole or not at depth because of the weight of the hose. Second, the water feed pump is liable to freeze in cold conditions because it works intermittently. Third, the burner of the steam generator sometimes misfires in strong wind. The first problem will be solved by attaching a pressure gauge to the end of the skirt; the latter two problems will easily be solved by heating and providing shelter from the wind.

## Acknowledgments

Mr. N. MURAKOSHI gave useful suggestions on the drilling system and operation. The drilling operation was carried out by the 28th JARE wintering members at Asuka Station directed by Mr. M. AYUKAWA and one of the authors, K. ISHIZAWA. The bottom depth and sewage amount were measured by wintering members at Asuka Station. We deeply thank them for their efforts.

## References

- NARUSE, R. and SUZUKI, Y. (1975): A steam-operated drill used by the 14th Japanese Antarctic Research Expedition (1972–1974). *Nankyoku Shiryo* (Antarct. Rec.), **53**, 53–56.
- NARUSE, R. and YOKOYAMA, K. (1975): Position, elevation and ice thickness of stations. *JARE Data Rep.*, **28** (Glaciology 3), 7–10.
- SATOW, K. (1977): Snow temperatures at a depth of 10 meters. *JARE Data Rep.*, **36** (Glaciology 4), 7–10.
- SCHMITT, R.P. and RODRIGUES, R. (1963): Glacier water supply and sewage disposal system. Symposium of Antarctic Logistics, ed. by National Academy of Sciences, National Research Council. Washington, 329–338.
- YONEZAWA, Y., IGARASHI, K., YOSHIDA, J., TOGASHI, S. and UEHARA, K. (1980): *Kikai* (Mechanical Division). *Nihon Nankyoku Chiiki Kansokutai Dai-20-ji Tai Hōkoku* (1978–1980) (Report of the 20th Japanese Antarctic Research Expedition 1978–1980), ed. by Natl Inst. Polar Res. Tokyo, 137–141.

(Received September 28, 1993; Revised manuscript received November 11, 1993)