

## Shallow Ice Coring and Borehole Casing at Dome Fuji Station, East Antarctica

Hideaki MOTOYAMA<sup>1</sup>, Hiroyuki ENOMOTO<sup>2</sup>,  
Morihiro MIYAHARA<sup>3</sup> and Okitsugu WATANABE<sup>1</sup>

東南極ドームふじにおける浅層コア掘削と掘削孔ケーシング

本山秀明<sup>1</sup>・榎本浩之<sup>2</sup>・宮原盛厚<sup>3</sup>・渡辺興亜<sup>1</sup>

**要旨：**東南極ドームふじにおける深層コア掘削計画が、1992年から南極地域観測隊 (JARE) によって行われている。JARE-34は、1993年12月から1994年1月にかけて、ドームふじ観測拠点において112 m深の浅層コア掘削と、掘削孔のケーシングを実施した。雪の圧密過程は、みずほ高原の特性と一致した。氷切削の速度には、氷の物理特性の情報が含まれている。

**Abstract:** A Deep Ice Coring Project at Dome Fuji, East Antarctica has been conducted by the Japanese Antarctic Research Expedition (JARE) since 1992. Shallow ice coring of 112 m in depth and casing of its borehole at Dome Fuji Station were carried out in December 1993 and January 1994 by JARE-34. The characteristics of snow densification showed similar features to those on Mizuho Plateau. The penetration rate of ice cutting can potentially provide useful information of physical properties of ice.

### 1. Introduction

A five-year glaciological program, the Deep Ice Coring Project at Dome Fuji, has been conducted by the Japanese Antarctic Research Expedition (JARE) since 1992. The topographical features such as surface elevation and bedrock elevation around Dome Fuji were measured by JARE-33 in 1992. Considering the topography, the construction site of Dome Fuji Station was located at the top of the dome. We, JARE-34 members, carried out shallow ice coring to a depth of 112 m and casing of the borehole at Dome Fuji Station during the period from December 1993 to January 1994. We here report the results of ice coring and the casing operation. Furthermore we describe characteristics of snow densification and the penetration rate of ice cutting at Dome Fuji.

<sup>1</sup> 国立極地研究所. National Institute of Polar Research, 9-10, Kaga, 1-chome, Itabashi-ku, Tokyo 173.

<sup>2</sup> 北見工業大学. Kitami Institute of Technology, 165, Koen-cho, Kitami 090.

<sup>3</sup> (株)地球工学研究所. Geo Tecs Co. Ltd., Shirakabe 4-29, Higashi-ku, Nagoya 461.

## 2. Background

The deep ice coring operation at Dome Fuji Station will be carried out in 1995-1996 by the wintering members of JARE-36 and JARE-37. To prevent borehole closure during the ice coring, the borehole will be filled with a proper drilling fluid (FUJITA *et al.*, 1994). As the fluid is poured into the borehole from the glacier surface, a casing is necessary to prevent leakage in the firn layer. The diameter of shallow ice coring borehole is 135 mm. Because the outer diameter of the casing tube is 250 mm, the borehole should be reamed to more than 250 mm.

For the past 20 years, we have used an electro-mechanical shallow drill equipped with antitorque side cutters at various sites in Antarctica and the Himalaya. As we have no experience in borehole reaming and casing, this is our first attempt.

A prototype reamer for borehole reaming was tested on top of the Greenland ice sheet in June 1992 and improved in Japan. A practice shallow drilling, reaming and casing operation was carried out on the Antarctic ice sheet near Syowa Station in April-May 1993. These devices were improved and tuned at Syowa Station. The

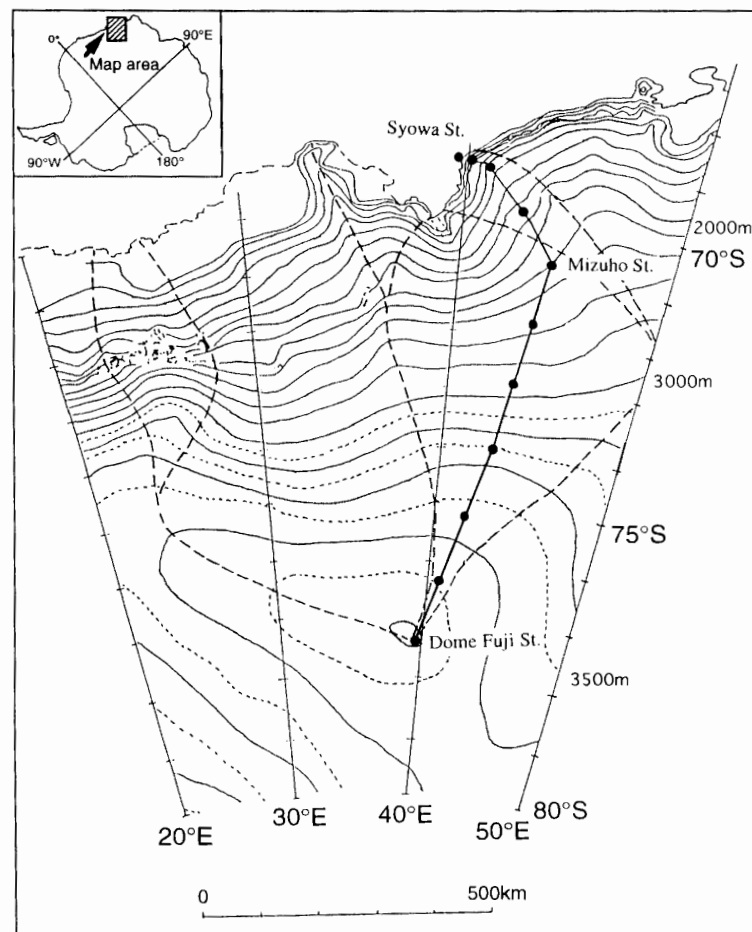

Fig. 1. Traverse route between Syowa and Dome Fuji Stations traced by JARE-34.

oversnow traverse party departed from Syowa Station on October 20, 1993 and arrived at Dome Fuji Station on November 28, 1993. The oversnow traverse route is shown in Fig. 1.

### 3. Operation

#### 3.1. Temporary drilling hut

Environmental conditions are severe at Dome Fuji even in summer. Air temperature is  $-30^{\circ}\text{C}$  to  $-40^{\circ}\text{C}$ , because of the high latitude ( $77^{\circ}19'S$ ) and high altitude (3810 m a.s.l.). The drilling hut was built up using three steps of scaffold and was

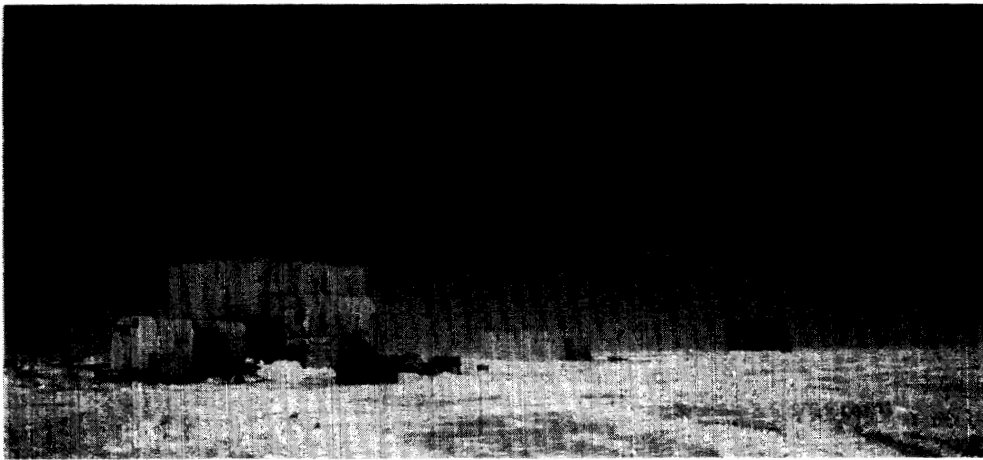

Fig. 2. Drilling hut at Dome Fuji Station.

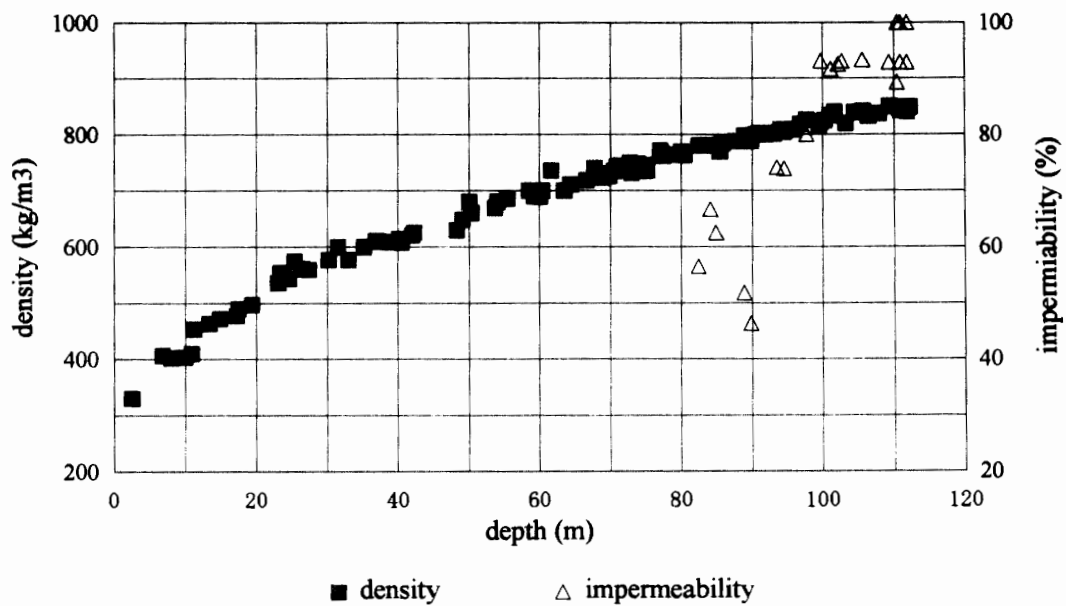

Fig. 3. Depth-density profile (square) and impermeability (triangle) of 112 m ice core.

completely covered with a tent cloth to protected from the cold wind (Fig. 2). Room temperature was raised to  $-30^{\circ}\text{C} \sim -20^{\circ}\text{C}$  by a kerosene heater, so that we could operate in the drilling hut even in the severe weather conditions. A 3 kVA generator installed in a heat insulation box was used for electrical power supply. The drilling operation was started at 09 LT and finished at 22 LT every day.

### 3.2. Shallow ice coring

We carried out shallow ice coring through the firn layer to 112 m depth. The ice coring system specifications are given in the Appendix. The depth-density profile is shown in Fig. 3. The firn density became  $800 \text{ kg/m}^3$  at 90 m depth. When the depth of the ice core was deeper than 100 m, the impermeability of ice core (KAMEDA, 1994) became almost 100 %. So we stopped the shallow ice coring at the depth of 112 m. The operation period was 12 days. The obtained ice core with a diameter of 104 mm was cut into 50 cm length which were wrapped in plastic tubes, after core log recording and density and impermeability measurements.

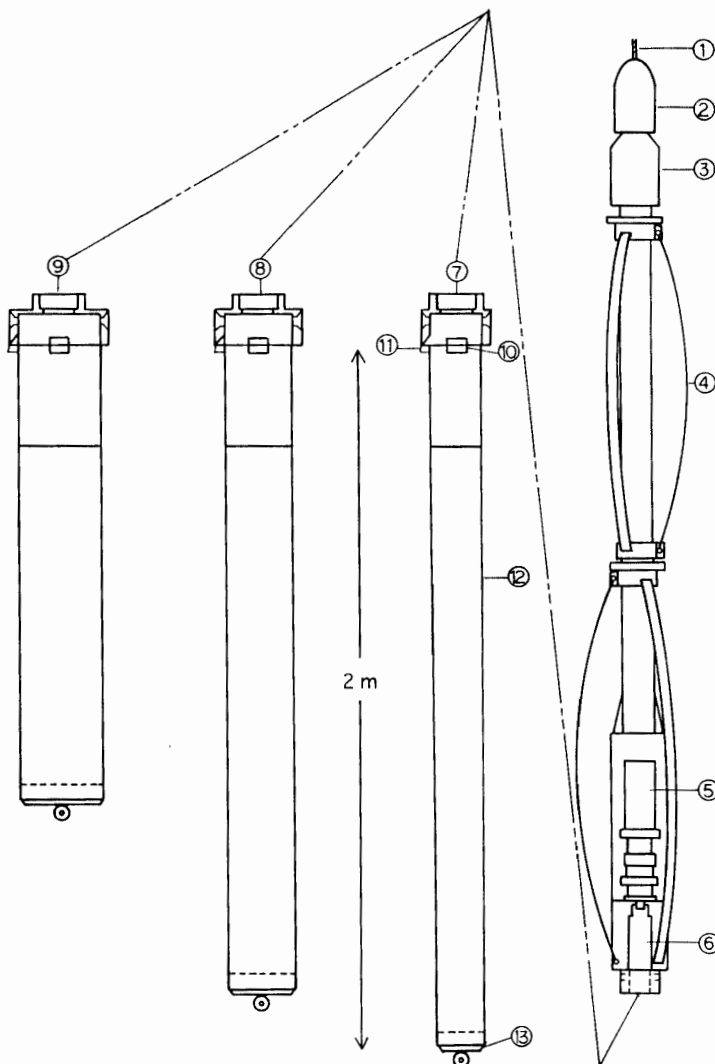

Fig. 4. Cross-sectional drawing of the electro-mechanical reamer.

1. Armored cable, 2. Cable joint, 3. Slip ring, 4. Anti-torque, 5. Motor (200 V, 5.5 A), 6. Gear reduction, 7. No. 1 reamer, 8. No. 2 reamer, 9. No. 3 reamer, 10. Hole for chip intake, 11. Cutter, 12. Chip chamber, 13. Outlet for chips.

### 3.3. Borehole reaming

The outer diameter of the casing tube was 250 mm, so that the shallow drilling borehole, of diameter 135 mm, had to be reamed before installing casing tubes. The reaming was carried out three times to enlarge the diameter to 180 mm, 221 mm and 254 mm. The reamer was equipped with double antitorque systems (leaf spring type) at the upper part. The ice chips were stored in a chip chamber with the same diameter as the original borehole to prevent chips from dropping into the borehole (Fig. 4). The reaming operation was successful, but some spilled reaming chips were accumulated at the bottom of the borehole. The reaming was finished at 86 m depth. The operation period was 15 days. The borehole figure is shown in Fig. 5.

### 3.4. Casing operation

The casing tube was 250 mm in outer diameter, 200 mm in inner diameter, and 3.13 m in length. It was made of special fiberglass (JOHNSEN *et al.*, 1994). Joints between casing tubes were fixed in place by stainless steel wire stoppers. A 4 m tripod was set up and a snow trench of 1.5 m depth was dug (Fig. 6). After twenty-nine

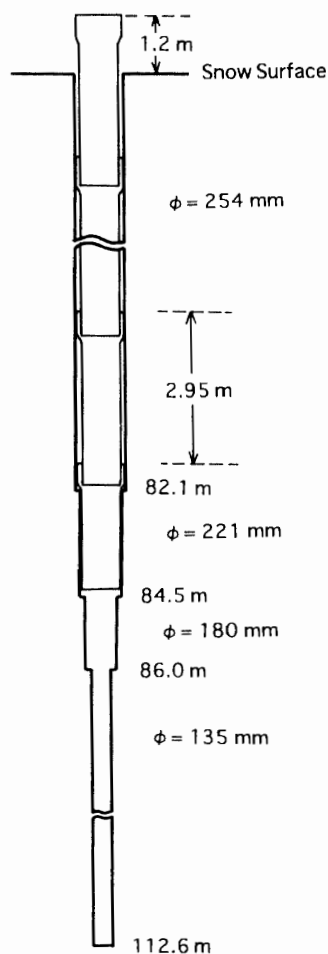

Fig. 5. Borehole figure after reaming operation and casing.



Fig. 6. Borehole casing in drilling hut at Dome Fuji Station.

casing tubes were connected, the casing depth reached 86 m (Fig. 5). The operation period was 2 days.

#### 4. Relationship Between Depth-Density Profile and Penetration Rate of Ice Cutting

The penetration rates of ice cutting is shown in Fig. 7 for shallow ice coring and in Fig. 8 for borehole reaming. The rotation speed of cutters was almost constant in each operation and the cutter load was the full weight of each machine. The penetration rate became smaller with depth, because of gradual hardening of firn. Sometimes, penetration rates showed smaller values than the general tendency. The

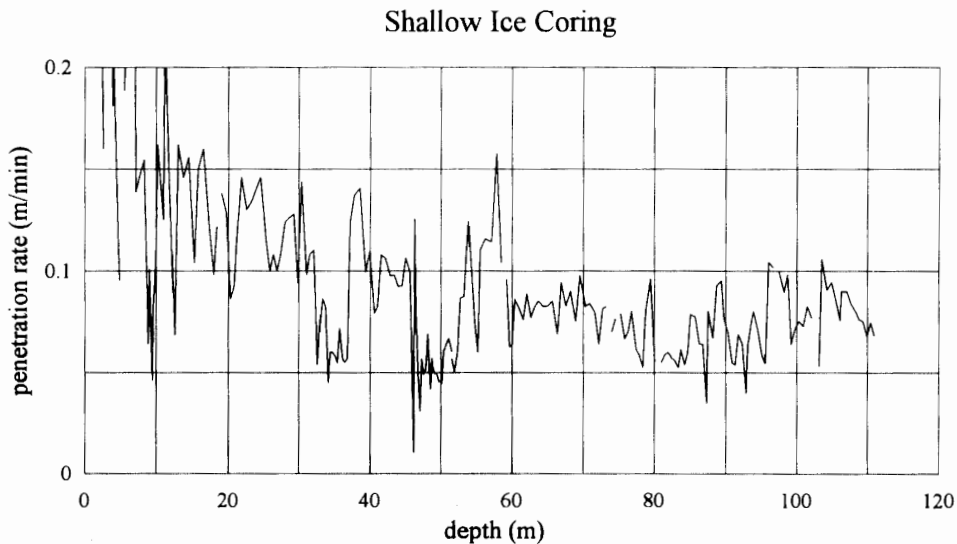

Fig. 7. Penetration rates of ice cutting for shallow ice coring.

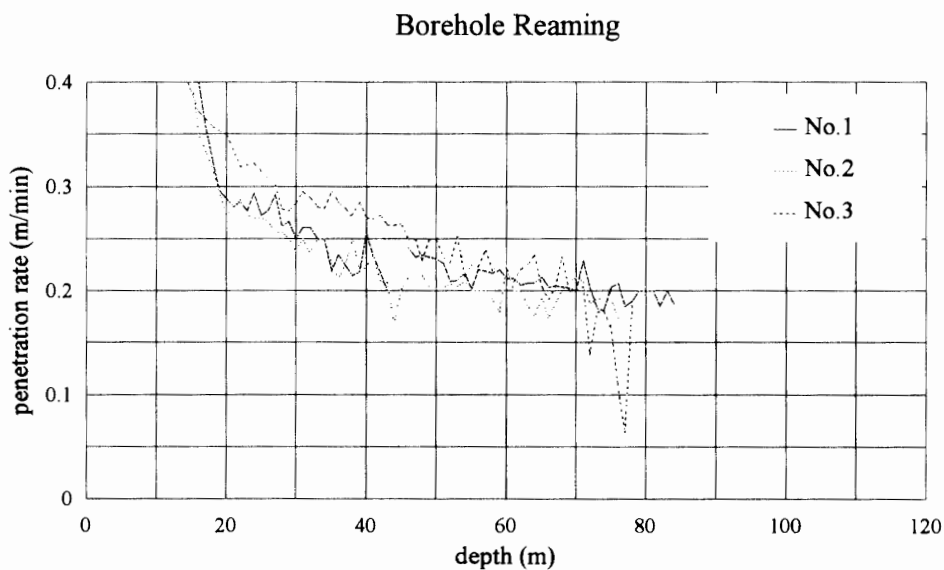

Fig. 8. Penetration rates of ice cutting for reaming.

relationship between penetration rate and snow density is not clear, but the penetration rate in ice cutting seems to have potential information on physical properties of snow/ice.

### 5. Characteristics of Dome Fuji Ice Core

The depth of pore close-off was more than 100 m (Fig. 3). AGETA *et al.* (1989) estimate the annual mean air temperature of  $-58^{\circ}\text{C}$  by snow temperature at 10 m depth and annual precipitation of 32 mm in water by detecting 1966 tritium at Dome Fuji. NISHIMURA *et al.* (1983) investigated the characteristics of snow densification on Mizuho Plateau and found that the snow densification rate depended on precipita-

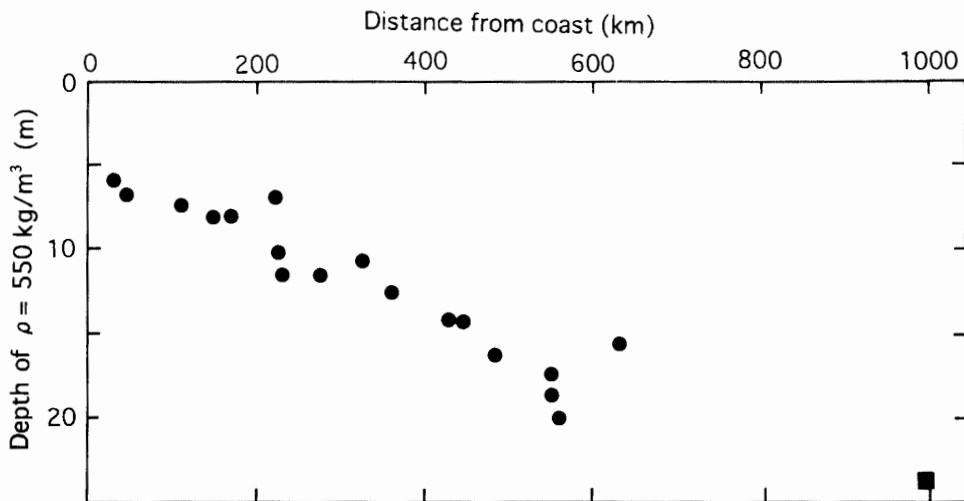

Fig. 9. Relation between the depth of the critical density  $550\text{ kg/m}^3$  and the distance from the coast (NISHIMURA *et al.*, 1983). A square represents a value obtained in the present work.

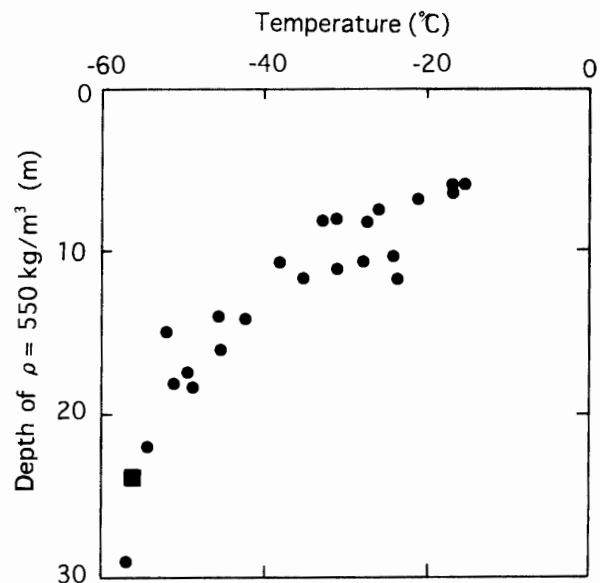

Fig. 10. Relation between mean annual temperature and the depth of density  $550\text{ kg/m}^3$  (NISHIMURA *et al.*, 1983). A square represents a value obtained in the present work.

tion rate and snow temperature. The relation between the depth of the critical density 550 kg/m<sup>3</sup> and distance from the coast, and the relation between mean annual temperature and the depth of density 550 kg/m<sup>3</sup>, are shown in Figs. 9 and 10, respectively. The densification process at Dome Fuji shows similar features to those on the Mizuho Plateau.

### Acknowledgments

We would like to express sincere thanks to all members of JARE-34, led by Prof. N. SATO of the National Institute of Polar Research (NIPR), who extended generous support in the field work. We also express our gratitude to the members of Greenland Ice Core Project and Japanese Arctic Glaciological Expedition for testing of prototype reamer and having useful suggestions.

### References

- AGETA, Y., KAMIYAMA, K., OKUHIRA, F. and FUJII, Y. (1989): Geomorphological and glaciological aspects around the highest dome in Queen Maud Land, East Antarctica. *Proc. NIPR Symp. Polar Meteorol. Glaciol.*, **2**, 88-96.
- FUJITA, S., YAMADA, T., NARUSE, R., MAE, S., AZUMA, N. and FUJII, Y. (1994): Drilling fluid for Dome F Project in Antarctica. *Mem. Natl Inst. Polar Res., Spec. Issue*, **49**, 347-357.
- KAMEDA, T. (1994): A study of transformation process from snow to ice in polar ice sheet. Doctor thesis of Hokkaido University, 120p.
- NISHIMURA, H., MAENO N. and SATOW, K. (1983): Initial stage of densification of snow in Mizuho Plateau, Antarctica. *Mem. Natl Inst. Polar Res., Spec. Issue*, **29**, 149-158
- JOHNSEN, S. J., GUNDERSTRUP, N. S., HANSEN, S. B., SCHWANDER, J. and RUFLI, H. (1994): The new improved version of the ISTUK ice core drill. *Mem. Natl Inst. Polar Res., Spec. Issue*, **49**, 9-23.

*(Received January 8, 1995; Revised manuscript received March 14, 1995)*

### Appendix. Operating System Specifications

1. Electro-mechanical shallow drill
  - Side cutters antitorque system
  - Four cutters and core catchers
  - Core diameter of 104 mm
  - Borehole diameter of 135 mm
  - Drill motor
    - type A: 400 W (100 V AC)
    - type B: 400 W (200 V AC)
2. Electro-mechanical reamer
  - Double equipped leaf spring antitorque system
  - Drill motor: 550 W (200 V AC)
  - No. 1 reamer: borehole diameter 135 mm → 180 mm  
three cutters, chip chamber of 2.0 m length
  - No. 2 reamer: borehole diameter 180 mm → 221 mm  
three cutters, chip chamber of 1.5 m length
  - No. 3 reamer: borehole diameter 221 mm → 254 mm  
three cutters, chip chamber of 1.3 m length



3. Winch system and others

Winch: steel armored cable 200 m, 800 W DC motor, mast of 5 m height

Drill controller: 0-200 V, max 7A

Winch controller: 0-100 V, max 10A

Generator: Yammar YDG3000, Kerosene, 3 kVA at 1000 hPa

4. Casing

Material: special fiberglass

Outer diameter 250 mm, inner diameter 200 mm

One piece: length 3.13 m (effective length 2.95 m), weight 30 kg